Evaluation of the Prompt Alerting Systems at Four Nuclear Power Stations

Prepared by D. A. Towers, G. S. Anderson, D. N. Keast/BB&N
J. L. Kenoyer, A. E. Desrosiers/PNL

Bolt Beranek and Newman, Inc.

Pacific Northwest Laboratory

**Prepared for
U.S. Nuclear Regulatory
Commission**

NOTICE

This report was prepared as an account of work sponsored by an agency of the United States Government. Neither the United States Government nor any agency thereof, or any of their employees, makes any warranty, expressed or implied, or assumes any legal liability of responsibility for any third party's use, or the results of such use, of any information, apparatus, product or process disclosed in this report, or represents that its use by such third party would not infringe privately owned rights.

Availability of Reference Materials Cited in NRC Publications

Most documents cited in NRC publications will be available from one of the following sources:

1. The NRC Public Document Room, 1717 H Street, N.W.
Washington, DC 20555
2. The NRC/GPO Sales Program, U.S. Nuclear Regulatory Commission,
Washington, DC 20555
3. The National Technical Information Service, Springfield, VA 22161

Although the listing that follows represents the majority of documents cited in NRC publications, it is not intended to be exhaustive.

Referenced documents available for inspection and copying for a fee from the NRC Public Document Room include NRC correspondence and internal NRC memoranda; NRC Office of Inspection and Enforcement bulletins, circulars, information notices, inspection and investigation notices; Licensee Event Reports; vendor reports and correspondence; Commission papers; and applicant and licensee documents and correspondence.

The following documents in the NUREG series are available for purchase from the NRC/GPO Sales Program: formal NRC staff and contractor reports, NRC-sponsored conference proceedings, and NRC booklets and brochures. Also available are Regulatory Guides, NRC regulations in the *Code of Federal Regulations*, and *Nuclear Regulatory Commission Issuances*.

Documents available from the National Technical Information Service include NUREG series reports and technical reports prepared by other federal agencies and reports prepared by the Atomic Energy Commission, forerunner agency to the Nuclear Regulatory Commission.

Documents available from public and special technical libraries include all open literature items, such as books, journal and periodical articles, and transactions. *Federal Register* notices, federal and state legislation, and congressional reports can usually be obtained from these libraries.

Documents such as theses, dissertations, foreign reports and translations, and non-NRC conference proceedings are available for purchase from the organization sponsoring the publication cited.

Single copies of NRC draft reports are available free upon written request to the Division of Technical Information and Document Control, U.S. Nuclear Regulatory Commission, Washington, DC 20555.

Copies of industry codes and standards used in a substantive manner in the NRC regulatory process are maintained at the NRC Library, 7920 Norfolk Avenue, Bethesda, Maryland, and are available there for reference use by the public. Codes and standards are usually copyrighted and may be purchased from the originating organization or, if they are American National Standards, from the American National Standards Institute, 1430 Broadway, New York, NY 10018.

Evaluation of the Prompt Alerting Systems at Four Nuclear Power Stations

Manuscript Completed: February 1982
Date Published: September 1982

Prepared by
D. A. Towers, G. S. Anderson, D. N. Keast/BB&N
J. L. Kenoyer, A. E. Desrosiers/PNL

Bolt Beranek and Newman, Inc.
10 Moulton Street
Cambridge, MA 02238

Pacific Northwest Laboratory
Richland, WA 99352

Prepared for
Division of Emergency Preparedness
Office of Inspection and Enforcement
U.S. Nuclear Regulatory Commission
Washington, D.C. 20555
NRC FIN B2311

ABSTRACT

This report presents evaluations of the prompt notification siren systems at the following four U.S. nuclear power facilities: Trojan, Three Mile Island, Indian Point, and Zion. The objective of these evaluations was to provide examples of an analytical procedure for predicting siren-system effectiveness under specific conditions in the 10-mile emergency planning zone (EPZ) surrounding nuclear power plants. This analytical procedure is discussed in report number PNL-4227.



SUMMARY

The purpose of this study was to provide examples of the analytical procedure developed in PNL-4227 for the evaluation of the effectiveness of siren systems for alerting the public in the vicinity of a nuclear power plant.

Evaluations of the prompt alerting siren systems at four U.S. nuclear power facilities are presented in this report. These facilities are Trojan, Three Mile Island, Indian Point, and Zion. Site-specific information was used for each system evaluation. The analytical procedure is summarized and details of computations for each evaluation are given.

TABLE OF CONTENTS

	page
Section 1. INTRODUCTION.....	1-1
2. EVALUATION OF THE PROMPT ALERTING SYSTEM FOR THE TROJAN NUCLEAR POWER STATION.....	2-1
2.1 Estimating Siren Sound Levels Out of Doors at Listener Sites.....	2-1
2.2 Estimating Indoor Sound Levels of Sirens.....	2-6
2.3 Assumptions about Chance of Alert.....	2-8
2.4 Alerting People Out of Doors.....	2-10
2.5 Alerting People Indoors.....	2-15
2.6 Alerting People in Motor Vehicles.....	2-19
3. EVALUATION OF THE PROMPT ALERTING SYSTEM FOR THE THREE MILE ISLAND NUCLEAR POWER STATION.....	3-1
3.1 Estimating Siren Sound Levels Out of Doors at Listener Sites.....	3-1
3.2 Estimating Indoor Sound Levels of Sirens.....	3-7
3.3 Assumptions about Chance of Alert.....	3-9
3.4 Alerting People Out of Doors.....	3-11
3.5 Alerting People Indoors.....	3-16
3.6 Alerting People in Motor Vehicles.....	3-18
4. EVALUATION OF THE PROMPT ALERTING SYSTEM FOR THE INDIAN POINT NUCLEAR POWER STATION.....	4-1
4.1 Estimating Siren Sound Levels Out of Doors at Listener Sites.....	4-1
4.2 Estimating Indoor Sound Levels of Sirens.....	4-5
4.3 Assumptions about Chance of Alert.....	4-8
4.4 Alerting People Out of Doors.....	4-10
4.5 Alerting People Indoors.....	4-15
4.6 Alerting People in Motor Vehicles.....	4-19

TABLE OF CONTENTS (Cont.)

	page
5. EVALUATION OF THE PROMPT ALERTING SYSTEM FOR THE ZION NUCLEAR POWER STATION.....	5-1
5.1 Estimating Siren Sound Levels Out of Doors at Listener Sites.....	5-1
5.2 Estimating Indoor Sound Levels of Sirens....	5-8
5.3 Assumptions about Chance of Alert.....	5-9
5.4 Alerting People Out of Doors.....	5-11
5.5 Alerting People Indoors.....	5-17
5.6 Alerting People in Motor Vehicles.....	5-23
APPENDIX A. Population-Weighted Random Selection of Listening Points at Trojan Site.....	A-1
B. Test Cases (Sample Scenarios) for Trojan Site.....	B-1
C. Siren Locations for Trojan EPZ.....	C-1
D. Estimation of A_{atm}	D-1
E. Dependence of Alert Upon Siren Duration.....	E-1
F. Random Selection of Population-Weighted Listening Points at Three Mile Island Site.....	F-1
G. Test Cases (Sample Scenarios) for Three Mile Island Site.....	G-1
H. Siren Locations for Three Mile Island EPZ.....	H-1
I. Analysis Input/Output Data for Three Mile Island.....	I-1
J. Random Selection of Population-Weighted Listening Points at Indian Point Site.....	J-1
K. Sample Scenarios for Evaluation of Siren Alerting at Indian Point Site.....	K-1
L. Siren Locations for Indian Point EPZ.....	L-1
M. Analysis Input/Output Data for Indian Point.....	M-1
N. Random Selection of Population-Weighted Listening Points at Zion Site.....	N-1
O. Sample Scenarios for Evaluation of Siren Alerting at Zion.....	O-1
P. Siren Locations for Zion EPZ.....	P-1
Q. Analysis Input/Output Data for Zion.....	Q-1

LIST OF FIGURES

	page
FIGURE 2-1. Flow of computations.....	2-9
2-2. Chance of alert for awakening people asleep.....	2-11
2-3. Distributions for detection by people out of doors.....	2-14
2-4. Chance of alert for people indoors at home (4-minute stationary siren).....	2-17
2-5. Chance of alert for people indoors at home (4-minute rotating siren).....	2-18
3-1. Flow of computations.....	3-10
3-2. Chance of alert for awakening people asleep.....	3-12
3-3. Distributions for detection by people out of doors.....	3-15
3-4. Chance of alert for people indoors at home (4-minute stationary siren).....	3-19
3-5. Chance of alert for people indoors at home (4-minute rotating siren).....	3-20
3-6. Chance of alert for people indoors at work in commercial/institutional establishments.....	3-21
4-1. Flow of computations.....	4-9
4-2. Chance of alert for awakening people asleep.....	4-11
4-3. Chance of alert for people indoors (4-minute rotating siren).....	4-14
4-4. Chance of alert for people indoors at home (4-minute rotating siren).....	4-17
4-5. Chance of alert for people indoors at work in commercial/institutional establishments.....	4-18
5-1. Flow of computations.....	5-10
5-2. Chance of alert for awakening people asleep.....	5-12
5-3. Chance of alert for people outdoors (4-minute stationary siren).....	5-15
5-4. Chance of alert for people outdoors (4-minute rotating siren).....	5-16
5-5. Chance of alert for people indoors at home (4-minute stationary siren).....	5-20

LIST OF FIGURES (Cont.)

	page
5-6. Chance of alert for people indoors at home (4-minute rotating siren).....	5-21
5-7. Chance of alert for people indoors at work in commercial/institutional establishments.....	5-22

LIST OF TABLES

		page
TABLE 2.1	Summary of Trojan siren system evaluation results.....	2-2
2.2	Meteorological conditions for the four sample scenarios used to evaluate the Trojan siren system.....	2-5
2.3	Atmospheric attenuation (A_{atm}) caused by wind and temperature gradients.....	2-7
2.4	Siren alerting ability for generalized categories of outdoor environments.....	2-13
2.5	Assumed activities and background noise environments for people indoors.....	2-16
2.6	Siren alerting for motorists.....	2-20
3.1	Summary of TMI siren system evaluation results.....	3-2
3.2	Meteorological conditions for the four scenarios used to evaluate the TMI siren system.....	3-6
3.3	Calculation of atmospheric attenuation, A_{atm} , caused by wind and temperature gradients (see appendix D for details).....	3-8
3.4	Siren alerting ability for generalized categories of outdoor environments.....	3-14
3.5	Assumed activities and background noise environments for people indoors.....	3-17
3.6	Siren alerting for motorists.....	3-22
4.1	Summary of Indian Point siren system evaluation results.....	4-2
4.2	Meteorological conditions for the four sample scenarios used to evaluate the Indian Point siren system.....	4-6
4.3	Calculation of atmospheric attenuation, A_{atm} , caused by wind and temperature gradients (see appendix D for details).....	4-7
4.4	Minimum background noise levels for generalized categories of outdoor environments (see Fig. 4-3 for distributions).....	4-13

LIST OF TABLES (Cont.)

	page
4.5 Assumed activities and background noise environments for people indoors.....	4-16
4.6 Siren alerting for motorists.....	4-20
5.1 Summary of Zion siren system evaluation results.....	5-2
5.2 Meteorological conditions for the four sample scenarios used to evaluate the Zion siren system.....	5-6
5.3 Calculation of atmospheric attenuation, A_{atm} , caused by wind and temperature gradients (see Appendix D for details).....	5-7
5.4 Minimum background noise levels for generalized categories of outdoor environments (see Figs. 5-3 and 5-4 for distributions).....	5-13
5.5. Assumed activities and background noise environments for people indoors.....	5-18
5.6. Minimum background noise levels for generalized categories of indoor activities/ environments.....	5-19
5.7. Siren alerting for motorists.....	5-24

FOREWORD

The work presented in this report was prepared by Bolt, Beranek and Newman Incorporated under subcontract No. B-A2740-A-V which, in turn, was funded under a Related Services Agreement with the U.S. Department of Energy Contract DE-AC06-76RLO 1830.



1. INTRODUCTION

This report presents evaluations of the prompt alerting siren systems at the following four U.S. nuclear power stations:

- Trojan (Oregon)
- Three Mile Island (Pennsylvania)
- Indian Point (New York)
- Zion (Illinois)

The purpose of these evaluations was to aid in the development of an analytical procedure for predicting siren-system effectiveness under defined conditions in the vicinity of nuclear power plants. The resulting analytical procedure is outlined in a separate report [1].

Because the analysis procedure evolved over the course of the four above evaluations, some of the calculations differ somewhat from one site evaluation to another. For example, all of the calculations for the Trojan evaluation were done manually. As a result, some broad generalizations regarding estimations of parameters such as shielding, air absorption, and atmospheric attenuation were adopted in order to render the analysis tractable. Subsequent evaluations employed a computer program, resulting in more precise calculations. In addition, the analyses for Trojan and Three Mile Island employed many different background noise level categories for the estimation of siren detectability outdoors. However, the results of these evaluations indicated that such a specific description of outdoor noise environments was not warranted, and therefore subsequent analyses used a more generalized estimation procedure for outdoor detectability.

As a result of the evolutionary process described above, the results of the four evaluations, although quite similar, are not directly comparable. With this qualification, the remaining sections of this report summarize the methods and results of the four evaluations.

2. EVALUATION OF THE PROMPT ALERTING SYSTEM FOR THE TROJAN NUCLEAR POWER STATION

This section summarizes the evaluation of the siren alerting system for the Trojan Nuclear Power Station. The procedure that was used consists of a detailed analysis of siren alerting capability at each of 50 randomly chosen listener locations, under four different "sample scenario" conditions. The random selection process for listener sites is described in Appendix A and the four test cases (sample scenarios) are included in Appendix B. The analysis is based on siren location as shown on maps provided in Appendix C.

The results of the evaluation for Trojan are summarized in Table 2.1 and indicate that the chance of alert is estimated to vary between 65% and 100%, depending on the sample scenario under consideration. The remainder of this section describes the procedure used to arrive at this conclusion.

2.1 Estimating Siren Sound Levels Out of Doors at Listener Sites

The first step in the procedure is to determine the siren in the vicinity of each selected listener site that is expected to produce the highest sound level at that site for each sample scenario. This choice is not always obvious, because the sound level caused by a particular siren at a given listener site depends not only on the sound output of the siren and its distance from the listener, but also on shielding and atmospheric effects (particularly wind direction). Therefore, it is generally necessary to evaluate several sirens in the vicinity of each listener site in order to determine the dominant one. As a general rule, the closest, highest-rated, nonshielded sirens are selected for evaluation at each site. Furthermore, sirens should be chosen such that they are distributed north, south, east, and west of the site (or in any other four mutually perpendicular directions)

TABLE 2.1. SUMMARY OF TROJAN SIREN SYSTEM EVALUATION RESULTS.

Scenario		Chance of Alert		
		Urban (%)	Rural (%)	Population-Weighted Average* (%)
No.	Description			
1	Warm Summer Weekend Day (clear to partly cloudy)	100	100	100
2	Summer Weekday Night (clear to partly cloudy)	78	72	76
3	Winter Weekday Evening (cool, damp, and overcast)	97	89	95
4	Winter Night (during rainstorm)	67	60	65

*Based on a total urban population of 46,000 and a total rural population of 18,600.

where possible to account for different wind directions. For the Trojan analysis, one to four sirens were evaluated at each of the 50 listener sites. Sites at which only one siren was considered were located so close to the chosen siren that the selection of additional sirens was obviously not warranted.

The next step in the procedure is to establish the outdoor sound level produced by the selected sirens at each listener location. This is accomplished by applying adjustments to the rated sound level of the siren as follows:

$$L(\text{listener}) = L(\text{siren}) - A_d - A_s - A_{\text{air}} - A_{\text{atm}}$$

where $L(\text{listener})$ is the outdoor siren sound pressure level at the listener site (dB), $L(\text{siren})$ is rated sound pressure level of the siren at 100 ft (dB), A_d is the distance attenuation (dB), A_s is shielding attenuation (dB), A_{air} is the air absorption (dB), and A_{atm} is the atmospheric attenuation caused by wind and temperature gradients (dB).

The rated sound pressure levels for the Trojan sirens were obtained from the manufacturer's literature as follows:

Federal Signal Corporation

Rotating "Thunderbolt" sirens	= 125 dBC @ 100 ft
Stationary Model STA10 or STL10 sirens	= 115 dBC @ 100 ft
Stationary Model 5 sirens	= 107 dBC @ 100 ft
Stationary Model 2 sirens	= 102 dBC @ 100 ft
Stationary Model LCS-1 sirens	= 86 dBC @ 100 ft

The first two adjustments (for distance and shielding) are the same for all four test cases and are based on information obtained from USGS maps. Distance attenuation beyond 100 ft is

calculated by assuming sound propagation from an acoustic point source with a reduction of 6 dB per distance doubled. It is calculated as follows:

$$A_d = 20 \log_{10}\left(\frac{d}{100}\right) ,$$

where d is the siren-to-listener distance (ft).

Shielding attenuation (A_s) is estimated based on the degree of break in the line-of-sight from siren-to-listener. Sirens are assumed to be at a height of 50 ft above terrain level and the listeners at a height of 5 ft. The break in line-of-sight is obtained by using ground contour information from USGS maps. For the Trojan analysis, a shielding attenuation of 15 dB was included if the break in line-of-sight was 50 ft or more. Otherwise, no attenuation was assumed.

The corrections for air absorption and atmospheric effects depend on the meteorological conditions for the particular scenario. The assumed conditions for the Trojan site are provided in Table 2.2 for the four test cases, based on local weather information.* In terms of air absorption, these conditions indicate attenuations ranging between 0.6 and 0.9 dB per 1000 ft, depending on the scenario [2,3]. For simplicity in the analysis, an average value of 0.8 dB per 1000 ft was assumed for all cases. Thus,

$$A_{\text{air}} = \frac{0.8d}{1000} ,$$

where d is the siren-to-listener distance (ft).

*Trojan Plant Environmental Impact Report - Amendment L, Fig. 2.3-4, Table 2.3-13 (March 1973).

TABLE 2.2. METEOROLOGICAL CONDITIONS FOR THE FOUR SAMPLE SCENARIOS USED TO EVALUATE THE TROJAN SIREN SYSTEM.

Scenario No.	Wind Conditions*	Temperature Gradient	Relative Humidity (%)	Temperature (°F)
1	10 mph from the north throughout the region, except upslope in the canyons	-2°C/100 m; Class A	50	75
2	5 mph from the south in the river valley, downslope in the canyons	+1.5°C/100 m; Class E	90	55
3	3 mph from the south, calm in the canyons	+1°C/100 m; Class E	80	55
4	15 mph from the south, 5 mph downslope in the canyons	+1°C/100 m; Class E	90	35

*Note: Weather data from the Trojan Plant indicate occasional conditions when the wind speed at lower elevations exceeds that at higher elevations. This unusual occurrence is assumed to be a measurement artifact, and has been ignored in this analysis.

The adjustment for atmospheric gradient effects (A_{atm}) is based on siren-to-listener azimuth with respect to wind direction and on wind and temperature gradient characteristics. Table 2.3 summarizes the calculation procedure for determining A_{atm} for each scenario at the Trojan site. A more detailed description of the estimation procedure for A_{atm} can be found in Appendix D.

Application of the above calculations yields the estimated outdoor sound pressure level for various sirens at each sample listener site, for each of the four scenarios. For the balance of the analysis, only the highest siren level at each listener site is generally used. An exception to this rule is made at listener sites where the sound level of a stationary siren is estimated to be between 0 and 6 dB lower than the sound level of a rotating-type siren, which had been determined to be the loudest siren. In such cases, the stationary siren was selected for further analysis. The reason for this exception is that the maximum sound level produced by a rotating siren is not continuous, and thus the total acoustic energy at the listener (as measured by the single event noise exposure level, or SEL) is approximately 6 dB less than for a stationary (i.e., continuous) siren with the same maximum sound level.

2.2 Estimating Indoor Sound Levels of Sirens

The result of the above calculations is a single outdoor siren sound pressure level at each of the 50 sample listener locations for each of the four test cases. Corresponding indoor levels are then obtained by subtracting typical values for residential building sound attenuation. For test cases 1 and 2 (summer), residential windows were assumed to be partly open; for test cases 3 and 4 (winter) residential windows were assumed to be closed. For the frequency region within the 500 Hz octave

TABLE 2.3. ATMOSPHERIC ATTENUATION (A_{atm}) CAUSED BY WIND AND TEMPERATURE GRADIENTS.

Sample Scenario No.	Listener Site Position with Respect to Siren Position*	Siren-to-Listener Distance (ft)	A_{atm} (dB)
1	Upwind	0 - 1000	0
		1000 - 2000	10
		>2000	20
1	Crosswind	0 - 4000	0
		>4000	10
1	Downwind	(all)	0
2	Upwind	0 - 1000	0
		1000 - 2000	10
		>2000	20
2	Crosswind	(all)	0
		Downwind	(all)
3	Same as Scenario No. 2, except $A_{atm}=0$ in canyons		
4	Same as Scenario No. 2		

*Defined with respect to the smaller angle (ϕ) between the source-to-receiver directional vector and the wind directional vector as follows:
 Downwind for $\phi = 0 - 45^\circ$
 Crosswind for $\phi = 45^\circ - 135^\circ$
 Upwind for $\phi = 135^\circ - 180^\circ$.

band, the sound attenuation into buildings is estimated to be 16 dB for test cases 1 and 2 and 27 dB for test cases 3 and 4 [4].

2.3 Assumptions about Chance of Alert

The outdoor and indoor siren levels calculated by the above procedure provide some of the information required for the analysis of the chance of alert. In addition, it is necessary to know the level of interfering background noise at the listener locations.

Figure 2-1 is a flow chart of the analysis computations. The analysis is divided into components (rows) that correspond to the possible activities of people for the various scenarios. The major components relate to people (1) at home (outside or inside), (2) at work, or (3) in motor vehicles. The chance of alert is estimated for each activity component and is then multiplied by the fraction of people likely to be engaged in that activity (activity fraction). The results are summed to obtain the overall chance of alert for each listener location and for each test case. Overall chances of alert for the various scenario (test case) conditions are then obtained by averaging the chances for all rural and/or urban sample listener sites. Note that all estimates assume siren signal duration of 4 minutes; an average of the "3 to 5 minutes" called for in Appendix 3 of NUREG-0654. The effects of different siren signal durations are discussed in Appendix E.

Siren detectability is a function of the siren signal level and of the background noise level in a "critical frequency band" centered at the signal frequency. For this analysis, outdoor and indoor detectability is estimated based on the signal-to-noise (S/N) difference in the 630-Hz 1/3-octave frequency band. The

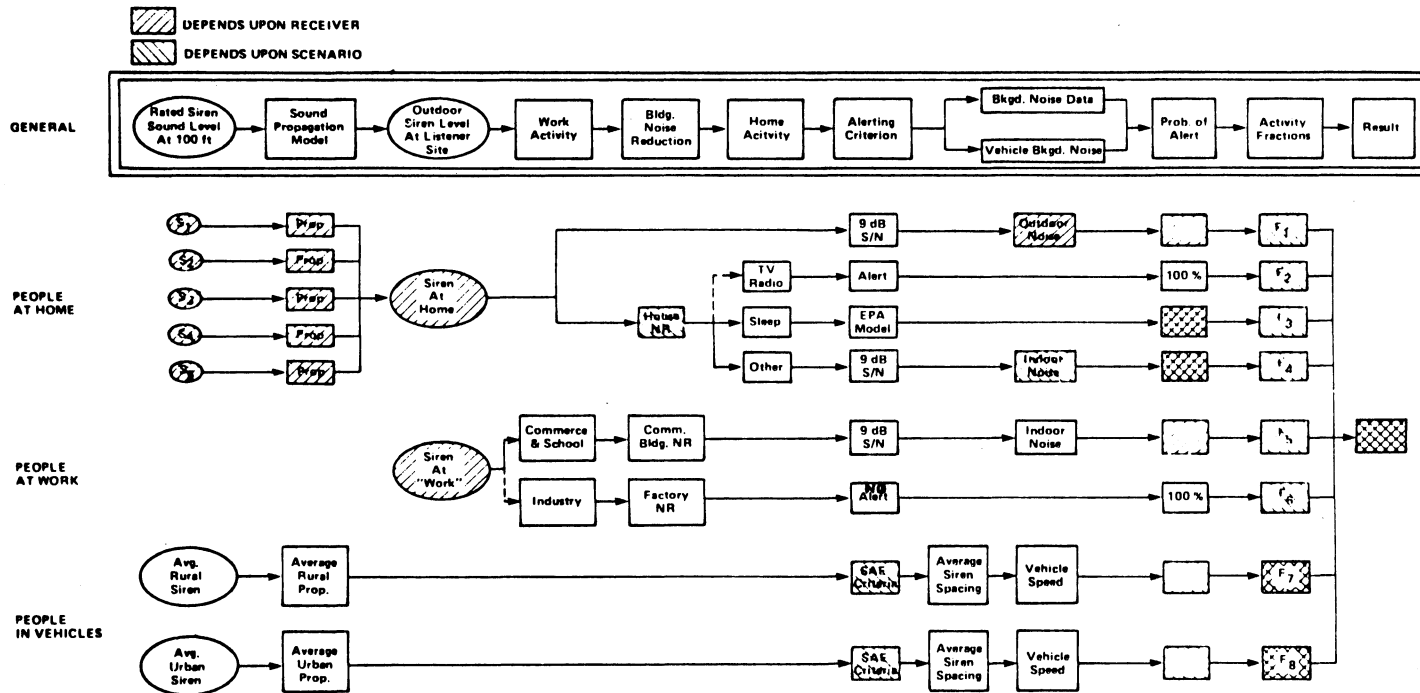

FIG. 2-1. FLOW OF COMPUTATIONS.

chosen criterion for alerting is that the given signal level must be 9 dB or more above the minimum background noise level at any time during a 4-minute period for people who are not sleeping (i.e., a S/N difference of 9 dB). The chance of alert during sleep is based on the indoor siren Single Event Level (SEL) - a measure of total acoustic energy - and the sleep-awakening model developed by the U.S. Environmental Protection Agency [5]. The graph used for estimating the chance of alert during sleep is shown in Fig. 2-2; for the Trojan analysis, the curve for the chance of awakening one out of two sleepers was used.

2.4 Alerting People Out of Doors

For the analysis of the ability of sirens to alert people out of doors, background noise levels are based on noise measurements conducted by BBN in the vicinity of the Trojan Plant in March 1981. These measurements consisted of collecting 1-minute statistical summaries of background noise for a period of 1 hour at various types of locations. The summaries provide the L_{90} (sound level exceeded 90% of the time) for 1-minute samples of data in the 1/3-octave frequency band centered at 630 Hz.* The data were used to calculate the chance of detection for various siren levels and signal durations based on the background noise levels and their variability. Generalized types of background noise environments were then established so that all sample listener sites would be included with one of these general categories. In each category, the siren sound level necessary to alert is 9 dB greater than the minimum background noise level that could exist in any 4-minute period (1 minute for rotating sirens), adjusted for the probability distribution of such minima. This is handled by assigning a "median alerting level"

*The L_{90} was used as a conservative estimate of the minimum sound level.

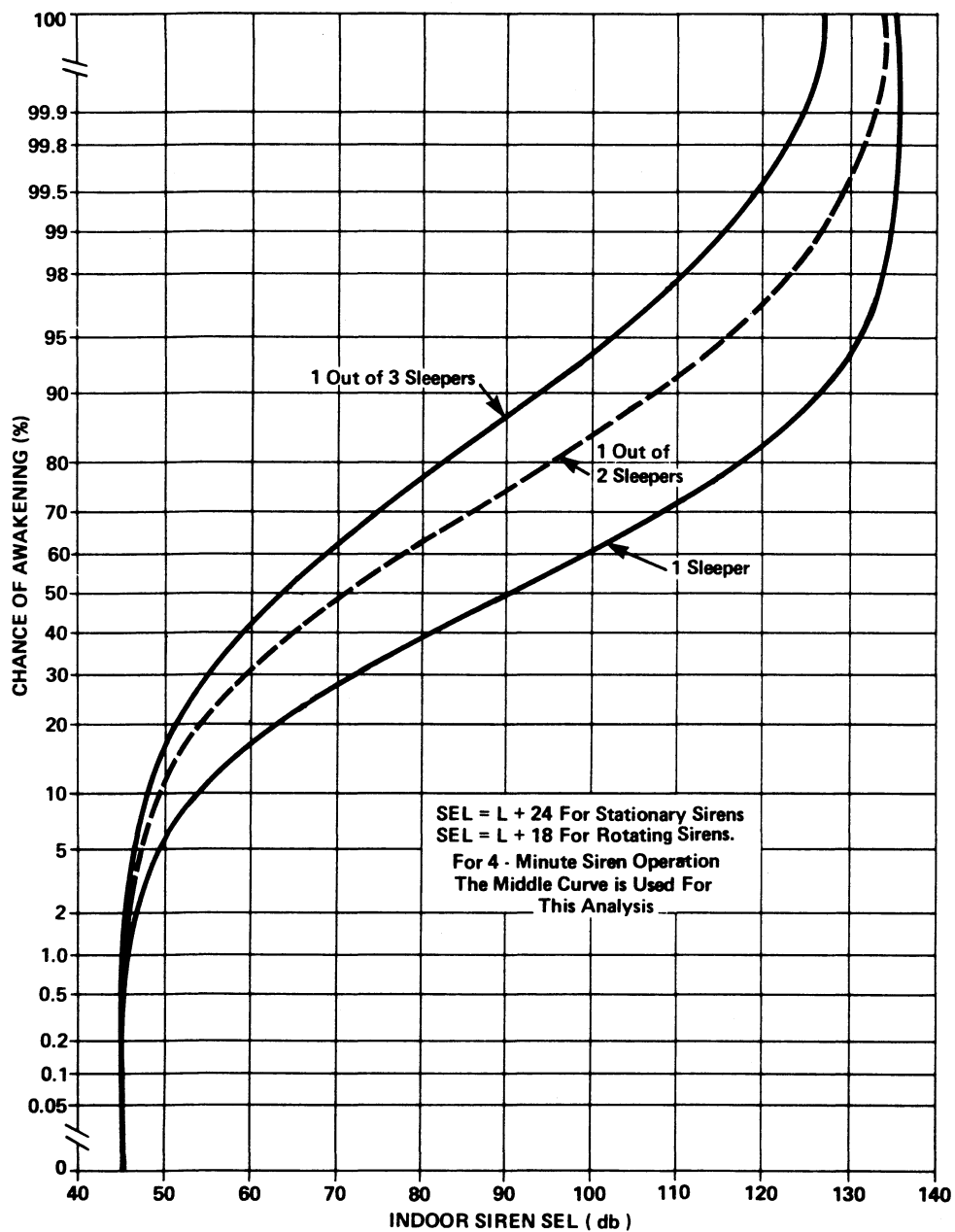

FIG. 2-2. CHANCE OF ALERT FOR AWAKENING PEOPLE ASLEEP.

for each background noise category and adjusting these levels in accordance with probability distributions generalized from the data.

The median alerting levels for each background noise category are listed in Table 2.4. These are keyed to corresponding distributions shown in Fig. 2-3. For example, assume that a rotating siren produces 54 dB at a given location adjacent to a major traffic artery. Table 2.4 indicates that the median alerting level at such locations is 55 dB and that the applicable distribution on Fig. 2-3 is No. 5. The siren level minus the median alerting level is $54 - 55 = -1$ dB. From distribution No. 5 on Fig. 2-3, we read 24% probability of alerting at -1 dB. Note that probabilities of greater than 99% on Fig. 2-3 are treated as 100%, and those less than 1% are treated as 0%.

Outdoor background noise in urban areas and along rural roadways is caused predominantly by motor vehicle traffic. It is generally insensitive to seasons of the year, but varies markedly with time of day. Minor traffic variations (i.e., less than a factor of 2 in traffic volume) have little effect on the background noise.

In rural areas remote from roadways, outdoor background noise can be seasonal (birds, insects, etc.) and can vary with the weather (wind, rain, waterflow, surf). Few people live or work in such "natural" acoustic environments.

During the analysis of the Trojan alerting system there were no instances where outdoor noise limited the effectiveness of the sirens.

Note that results are given separately for stationary sirens and rotating sirens. This is because rotating sirens would actually produce their estimated sound level during about one

TABLE 2.4. SIREN ALERTING ABILITY FOR GENERALIZED CATEGORIES OF OUTDOOR ENVIRONMENTS.

Generalized Background Noise Environment	Median Alerting Level (dB)		Applicable Distribution ¹	
	Rotating Siren (4 min)	Stationary Siren (4 min)	Rotating Siren (4 min)	Stationary Siren (4 min)
I. URBAN				
A. Adjacent to Major Traffic Artery	55	53	No. 5	No. 3
B. Remote from Major Traffic Artery	48	46	No. 5	No. 4
II. RURAL				
A. Within View of Major Noise Sources				
1. Highway I-5 ²	63	61	No. 6	No. 4
2. Highway US-30 ³	48	48	No. 6	No. 4
3. Port of Longview	53	52	No. 3	No. 2
B. Remote from Major Noise Sources				
1. No Wind or Water Flow Noise	41	41	No. 3	No. 1
2. Subject to Wind Noise	45	44	No. 5	No. 3
3. Subject to Water Flow Noise ⁴	57	57	No. 1	No. 1
III. INDUSTRIAL ⁵	55	54	No. 4	No. 2

NOTES:

1. See Fig. 2-3.
2. Alerting levels apply for sites within 500 ft, with view angle (θ) of 180° to highway; beyond 500 ft, levels should be reduced by $10 \log_{10} (D/500)$, where D = dist. from highway in ft; for view angles less than 180° , levels should be further reduced by $10 \log_{10} (180/\theta)$.
3. Alerting levels apply for sites within 1600 ft, with view angle (θ) of 180° to highway; beyond 1600 ft, levels should be reduced by $10 \log_{10} (D/1600)$, where D = dist. from highway in ft; for view angles less than 180° , levels should be further reduced by $10 \log_{10} (180/\theta)$.
4. Alerting levels apply at 300 ft from stream; for other distances adjust levels by $10 \log_{10} (300/\text{distance})$.
5. Alerting levels apply at 1000 ft from source; for other distances adjust levels by $20 \log_{10} (1000/\text{distance})$.

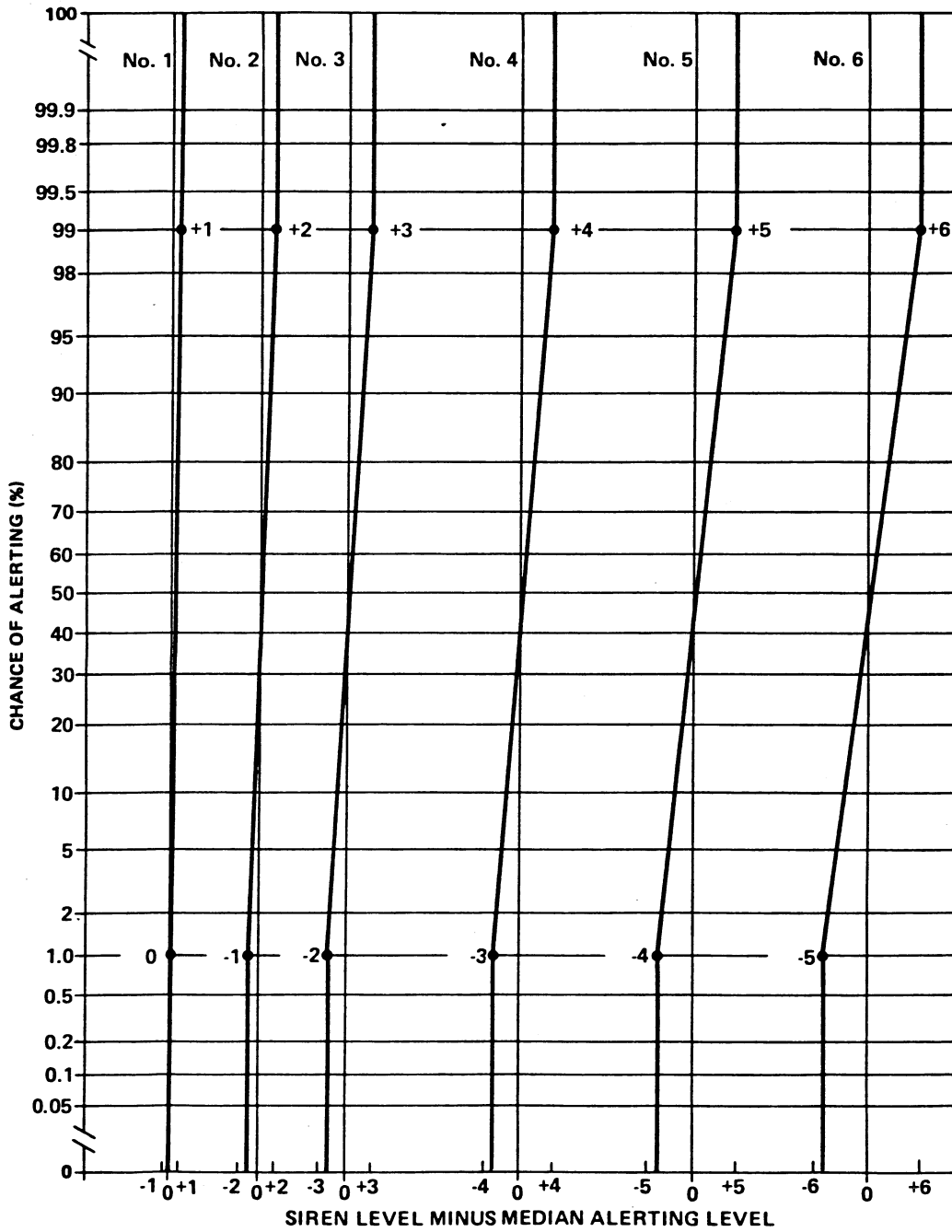

FIG. 2-3. DISTRIBUTIONS FOR DETECTION BY PEOPLE OUT OF DOORS.

quarter of the presumed 4-minute operating time at any particular listener location. Thus, the results for rotating sirens are based on 1-minute statistics rather than on 4-minute statistics.

In summary, information regarding siren type, estimated siren sound level, background noise category at the listener site, and test-case conditions are used in conjunction with Table 2.4 and Fig. 2-3 to estimate the chance of siren detection outdoors.

2.5 Alerting People Indoors

For the analysis of alerting people indoors at home, three types of activities are considered. These are (1) listening to radio or TV, (2) sleeping, or (3) other activities that range from quiet to noisy situations. Table 2.5 provides the percentages assumed for various activities for each scenario.

For people listening to radio or TV, the chance of alert is 100%. For people sleeping, the chance of alert is calculated from the indoor siren SEL using the relationship shown in Fig. 2-2 for the chance of awakening one out of two sleepers. For all other indoor activities, the chance of alert is based on classifications of actual indoor background noise measurements under a wide variety of conditions.

Results for test cases 1 and 3 are provided in Fig. 2-4 for 4-minute stationary sirens and in Fig. 2-5 for 4-minute rotating sirens. Thus, given the siren type, indoor siren level, and test case condition, these figures are used to estimate the chance of alert for indoor activities other than sleeping or listening to radio or TV.

TABLE 2.5. ASSUMED ACTIVITIES AND BACKGROUND NOISE ENVIRONMENTS FOR PEOPLE INDOORS.

Scenario	Percentages of People Engaged in Various Activities Indoors (%)						
	At Place of Business	Listening to TV/Radio	Sleeping	Indoor Noise Environment			
				Obviously Noisy ¹	Busy and Active ²	Isolated ³	Obviously Quiet ⁴
1. Warm Summer Weekend Day (clear to partly cloudy)	--	50	--	--	15	10	25
2. Summer Weekday Night (clear to partly cloudy)	5	--	95	--	--	--	--
3. Winter Weekday During Evening Commuting Hours (cool, damp, overcast)	--	20	--	5	50	20	5
4. Winter Night During Rainstorm	5	--	95	--	--	--	--

NOTES:

1. Vacuum cleaning, dishwasher, shower, vent fan on, etc.
2. Dinner conversation, kitchen work, playing music, children at play, etc.
3. Noise-producing activity in adjacent room, soft background music, etc.
4. Reading, study, eating alone.

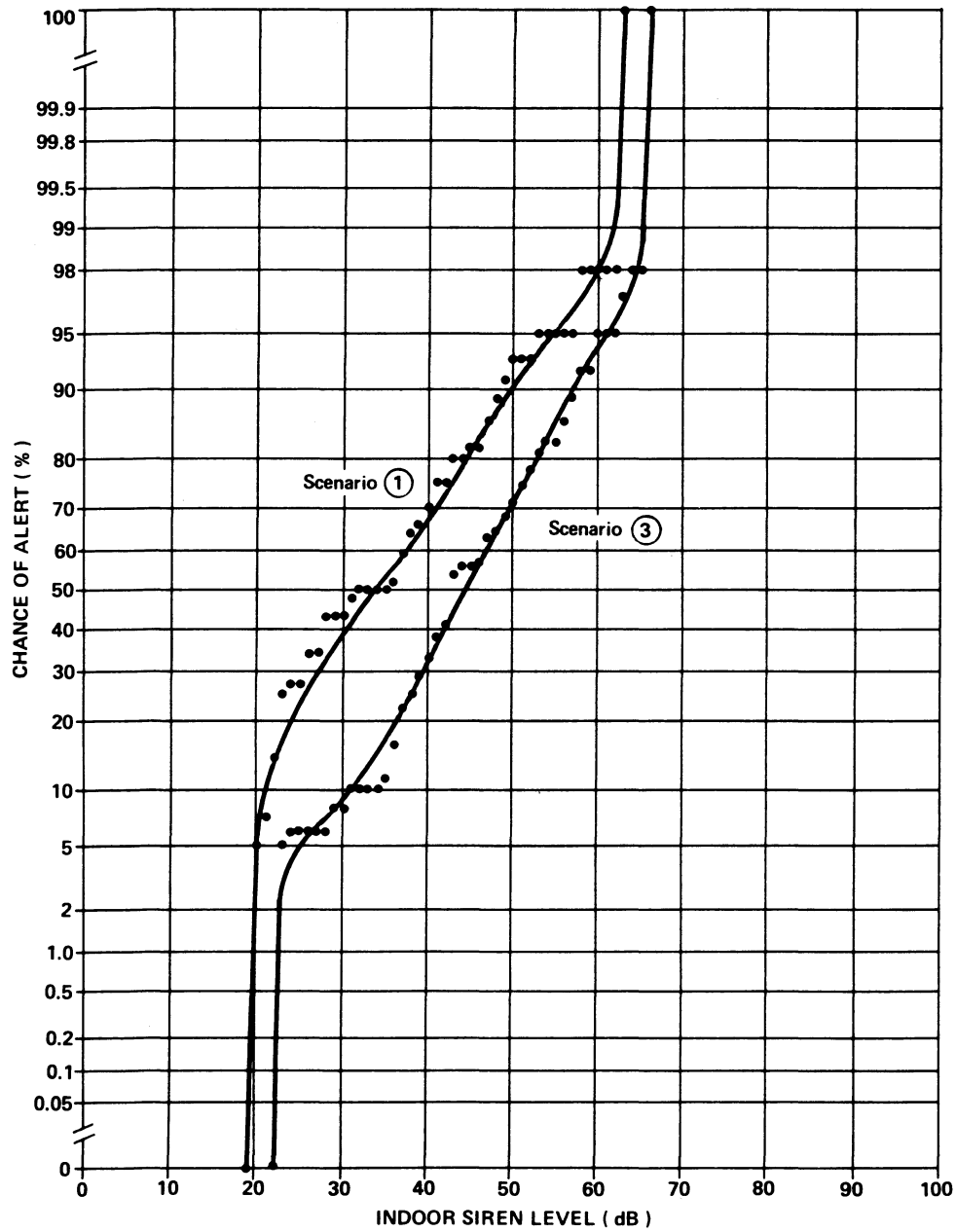

FIG. 2-4. CHANCE OF ALERT FOR PEOPLE INDOORS AT HOME (4-MINUTE STATIONARY SIREN).

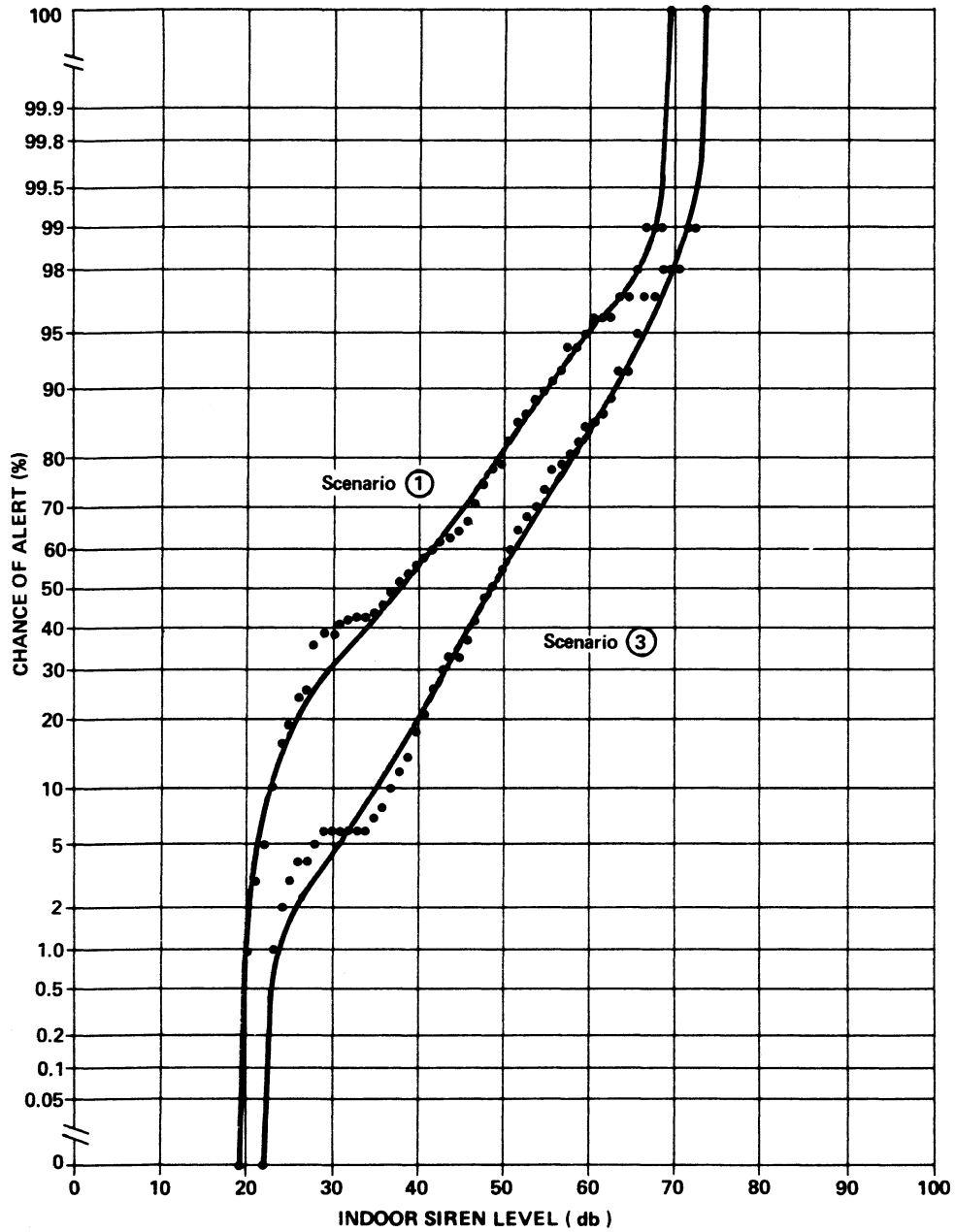

FIG. 2-5. CHANCE OF ALERT FOR PEOPLE INDOORS AT HOME (4-MINUTE ROTATING SIREN).

For the analysis of alerting at work, two activity categories are considered: (1) commercial/institutional, and (2) industrial environments. In the case of Trojan, only the nighttime scenarios (test cases 2 and 4) include people at work. For these cases, essentially all nighttime work was assumed to occur in industrial environments and none of these people is likely to be alerted because of building attenuation and high background noise levels. Thus, the chance of alert was assumed to be 0% at work at night for the Trojan analysis. In actuality, it is possible that these people would be alerted by some means (phone, radio) other than sirens, and hence our estimates may be low as a result.

2.6 Alerting People in Motor Vehicles

The analysis for the alerting of motorists is based on the assumption of an average siren signal strength and spacing throughout the EPZ. The probability that a motorist will pass within the alert range of a siren during its 4-minute operation is estimated as follows:

$$C = \frac{2R+d}{L} \times 100 \text{ (not to exceed 100\%)}$$

where C is the chance of alert (%), R is the maximum alert distance (ft), d is distance traveled in 4 minutes (ft), and L is the average siren spacing (ft). Separate analyses were carried out for urban and rural areas of the Trojan EPZ.

The average urban siren produces a sound level of 125 dB at 100 ft, and the average rural siren produces a sound level of 119 dB at 100 ft. Alerting ability was evaluated by using the results of a study for the Society of Automotive Engineers (SAE) [6]. Siren alerting levels for speeds of 55 mph and 30 mph with windows shut or open were first determined from the SAE study results. The average siren source levels for rural and urban

areas were then reduced to alerting levels in accordance with the propagation models from current NRC guidelines (i.e., 10 dB/double distance) [7]. In this manner, the maximum alert distance (R) was calculated for each driving condition. The distance traveled in 4 minutes (d) was calculated based on speed for each case, and the average siren spacing (L) was estimated to be 4,785 ft for urban areas and 6,895 ft for rural areas.

The calculations of alerting ability for motorists are summarized in Table 2.6. The results indicate that the chance of alert is expected to be 100% for all conditions applicable to the Trojan analysis.

TABLE 2.6. SIREN ALERTING FOR MOTORISTS.

Area	Vehicle Speed (mph)	Vehicle Window Condition	Reqd. Signal for Alert (dB)	Max. Alert Dist., R (ft)	4-min Travel dist., d (ft)	Avg. Siren Spacing, L (ft)	Chance of Alert (%)
URBAN	55	closed	96	750	19,360	4785	100
		open	90	1130	19,360	4785	100
	30	closed	89	1210	10,560	4785	100
		open	86	1500	10,560	4785	100
RURAL	55	closed	96	490	19,360	6895	100
		open	90	750	19,360	6895	100
	30	closed	89	800	10,560	6895	100
		open	86	980	10,560	6895	100

3. EVALUATION OF THE PROMPT ALERTING SYSTEM FOR THE THREE MILE ISLAND NUCLEAR POWER STATION

This section summarizes the evaluation of the siren alerting system for the Three Mile Island Nuclear Power Station (TMI). The procedure that was used consists of a detailed analysis of siren alerting capability at each of 50 randomly chosen listener locations, under four different "sample scenario" conditions. The random selection process for listener sites is described in Appendix F and the four test cases (sample scenarios) are included in Appendix G. The analysis is based on existing and proposed siren locations as of 30 June 1981. Maps that shown the siren locations are provided in Appendix H.

The results of the evaluation for TMI are summarized in Table 3.1 and indicate that the chance of alert is estimated to vary between 49% and 90% depending on the sample scenario under consideration. The remainder of this report describes the procedure used to arrive at this conclusion. Input and output data for the analysis are included in Appendix I.

3.1 Estimating Siren Sound Levels Out of Doors at Listener Sites

The first step in the procedure is to determine the siren in the vicinity of each selected listener site that is expected to produce the highest sound level at that site for each sample scenario. This choice is not always obvious, because the sound level caused by a particular siren at a given listener site depends not only on the sound output of the siren and its distance from the listener, but also on shielding and atmospheric effects (particularly wind direction). Therefore, it is generally necessary to evaluate several sirens in the vicinity of each listener site in order to determine the dominant one. As a general rule, the closest, highest-rated, nonshielded sirens are selected for evaluation at each site. Furthermore, sirens are

TABLE 3.1. SUMMARY OF TMI SIREN SYSTEM EVALUATION RESULTS.

Scenario		Chance of Alert		
		Urban (%)	Rural (%)	Population-Weighted Average*
No.	Description	(%)	(%)	(%)
1	Warm Summer Weekday Afternoon (clear to partly cloudy)	96	88	90
2	Summer Weekday Night (clear to partly cloudy)	82	66	70
3	Winter Weekday Evening (cold and overcast)	89	76	80
4	Winter Night (during snowfall)	66	42	49

*Based on a total urban population of 46,573 and a total rural population of 119,722.

chosen such that they are distributed north, south, east, and west of the site (or in any other four mutually perpendicular directions) where possible to account for different wind directions. For the TMI analysis, four or six sirens were evaluated at 46 of the 50 listener sites. Only two or three sirens were considered at the remaining four sites. These sites were either located at the fringes of the EPZ such that sirens could not be chosen in all directions, or they were located so close to one or two sirens that the selection of additional sirens was obviously not warranted.

The next step in the procedure is to establish the outdoor sound level produced by the selected sirens at each listener location. This is accomplished by applying adjustments to the rated sound level of the siren as follows:

$$L(\text{listener}) = L(\text{siren}) - A_d - A_s - A_{\text{air}} - A_{\text{atm}}$$

where $L(\text{listener})$ is the outdoor siren sound pressure level at the listener site (dB), $L(\text{siren})$ is rated sound pressure level of the siren at 100 ft (dB), A_d is the distance attenuation (dB), A_s is shielding attenuation (dB), A_{air} is the air absorption (dB), and A_{atm} is the atmospheric attenuation caused by wind and temperature gradients (dB).

The rated sound pressure levels for the TMI sirens were estimated based on anechoic chamber performance data, obtained with the cooperation of the Metropolitan Edison Company. These data indicate sound pressure levels of 142.9 dBC and 145 dBC for stationary and rotating sirens respectively, measured at a distance of 2 meters. These levels were reduced by 23.7 dB to extrapolate to the level at a distance of 100 feet (see distance adjustment discussion below) and then increased by 3 dB to account for the presence of a ground plane for sirens in the

field. The resulting rated sound pressure levels at 100 ft are therefore 122 dB for TMI stationary sirens and 124 dB for TMI rotating sirens.

The first two adjustments (for distance and shielding) are the same for all four test cases and are based on information obtained from USGS maps. Distance attenuation beyond 100 ft is calculated by assuming sound propagation from an acoustic point source with a reduction of 6 dB per distance doubled. It is calculated as follows:

$$A_d = 20 \log_{10} \left(\frac{d}{100} \right) ,$$

where d is the siren-to-listener distance (ft).

Shielding attenuation (A_s) is estimated using the following formula for the attenuation of a rigid straight barrier for sound incident from a point source [2]:

$$A_s = \begin{cases} 20 \log \frac{\sqrt{2\pi N}}{\tanh \sqrt{2\pi N}} + 5 \text{ dB} & \text{for } N > -0.2 \\ 0 \text{ dB} & \text{for } N < -0.2 \end{cases}$$

N is the Fresnel number (dimensionless):

$$N = \pm \frac{2}{\lambda} (A + B - d)$$

Where λ = wavelength of sound, ft (1.79 ft for 630-Hz siren tone)

d = straight-line distance between source and receiver, ft

A + B = shortest path length of wave travel over the barrier between source and receiver, ft

+ sign = receiver in the shadow zone (i.e., barrier obstructs line-of-sight)

- sign = receiver in the bright zone (i.e., barrier doesn't obstruct line-of-sight)

When N is negative, the above equation for A_s is evaluated by replacing N with |N|, and by replacing tanh with tan.

Shielding attenuation is limited to a maximum of 24 dB based upon a large body of experimental data. For the TMI analysis, sirens are assumed to be at a height of 52 ft above terrain level, listener sites are assumed to be at a height of 5 ft above terrain level, and barrier heights are obtained from ground contour information on USGS maps.

The adjustments for air absorption and atmospheric effects depend on the meteorological conditions for the particular scenario. The assumed conditions for the TMI site are provided in Table 3.2 for the four test cases, based on local weather information.* In terms of air absorption, these conditions indicate the following attenuation rates based upon temperature and relative humidity [3]:

Scenario	A_{air} (dB per 1000 ft)
1	0.88
2	0.79
3	0.55
4	0.64

The adjustment for atmospheric gradient effects (A_{atm}) is based on siren-to-listener azimuth with respect to wind direction

*Three Mile Island Nuclear Station Unit 2 Environmental Impact Report, Chapter 2.

TABLE 3.2. METEOROLOGICAL CONDITIONS FOR THE FOUR SAMPLE SCENARIOS USED TO EVALUATE THE TMI SIREN SYSTEM.

Scenario No.	Wind Conditions*	Temperature Gradient	Relative Humidity (%)	Temperature (°F)
1	5 mph from the east	-1.0°F/100 ft Class A	65	85
2	5 mph from the northwest	+0.5°F/100 ft Class E	80	65
3	3 mph from the southeast	-0.5°F/100 ft Class D	70	40
4	15 mph from the west	-0.5°F/100 ft Class D	90	25

*At 100 ft above ground level.

and on wind and temperature gradient characteristics. Table 3.3 summarizes the calculation procedure for determining A_{atm} for each scenario at the TMI site. A more detailed description of the estimation procedure for A_{atm} can be found in Appendix D.

Application of the above calculations yields the estimated outdoor sound pressure level for various sirens at each sample listener site, for each of the four scenarios. For the balance of the analysis, only the highest siren level at each listener site is generally used. An exception to this rule is made at listener sites where the sound level of a stationary siren is estimated to be between 0 and 6 dB lower than the sound level of a rotating-type siren, which had been determined to be the loudest siren. In such cases, the stationary siren was selected for further analysis. The reason for this exception is that the maximum sound level produced by a rotating siren is not continuous, and thus the total acoustic energy at the listener (as measured by the single event noise exposure level, or SEL) is approximately 6 dB less than for a stationary (i.e., continuous) siren with the same maximum sound level.

3.2 Estimating Indoor Sound Levels of Sirens

The result of the above calculations is a single outdoor siren sound pressure level at each of the 50 sample listener locations for each of the four test cases. Corresponding indoor levels are then obtained by subtracting typical values for residential building sound attenuation. For test cases 1 and 2 (summer), residential windows were assumed to be partly open; for test cases 3 and 4 (winter) residential windows and storm windows were assumed to be closed. For the frequency region within the 500 Hz octave band, the sound attenuation into buildings is estimated to be 16 dB for test cases 1 and 2 and 31 dB for test cases 3 and 4 [4]. For commercial buildings, the outdoor-to-indoor

TABLE 3.3. CALCULATION OF ATMOSPHERIC ATTENUATION, A_{atm} , CAUSED BY WIND AND TEMPERATURE GRADIENTS (SEE APPENDIX D FOR DETAILS).

Siren-to-Listener Distance, D (Ft) Relative to X_0 (Ft)	A_{atm} (dB)			
$D \leq 1.2 X_0$	0			
$1.2 X_0 < D \leq 1.7 X_0$	5			
$1.7 X_0 < D \leq 2.4 X_0$	10			
$2.4 X_0 < D \leq 3.4 X_0$	15			
$3.4 X_0 < D$	20			

Computation of X_0

$$X_0 \approx \frac{47S}{\sqrt{C}} \cdot f\left(\frac{R}{S}\right) = 1057 / \sqrt{\alpha\beta \cos\phi - a}$$

Scenario	<u>1</u>	<u>2</u>	<u>3</u>	<u>4</u>
Wind Direction, θ_w	90°	315°	135°	270°
$\Delta T^\circ F$ (150'-50')	-1	+0.5	-0.5	-0.5
$a = \alpha z = \Delta T / (\ln 150' - \ln 50')$	-0.91	+0.46	-0.46	-0.46
Wind Speed, V_2 ft/sec @ 100ft	7.3	7.3	4.4	22
$\alpha\beta = V_2 / (\ln 100' - \ln 2')$	1.87	1.87	1.12	5.6
$R/S = 5'/50'$	0.1			
$f(R/S)$	0.45			
X_0 (min) @ $\phi = 0$	634'	890'	840'	429'
$\phi_c = \cos^{-1} \left(\frac{\alpha}{\beta}\right)$	119°	76°	114°	95°

noise reduction is estimated to be 31 dB, assuming closed and sealed windows for all four scenarios.

3.3 Assumptions about Chance of Alert

The outdoor and indoor siren levels calculated by the above procedure provide some of the information required for the analysis of the chance of alert. In addition, it is necessary to know the level of interfering background noise at the listener locations.

Figure 3-1 is a flow chart of the analysis computations. The analysis is divided into components (rows) that correspond to the possible activities of people for the various scenarios. The major components relate to people (1) at home (outside or inside), (2) at work, or (3) in motor vehicles. The chance of alert is estimated for each activity component and is then multiplied by the fraction of people likely to be engaged in that activity (activity fraction). The results are summed to obtain the overall chance of alert for each listener location and for each test case. Overall chances of alert for the various scenario (test case) conditions are then obtained by averaging the chances for all rural and/or urban sample listener sites. Note that all estimates assume siren signal duration of 4 minutes: an average of the "3 to 5 minutes" called for in Appendix 3 of NUREG-0654. The effects of different siren signal durations are discussed in Appendix E.

Siren detectability is a function of the siren signal level and of the background noise level in a "critical frequency band" centered at the signal frequency. For this analysis, outdoor and indoor detectability is estimated based on the signal-to-noise

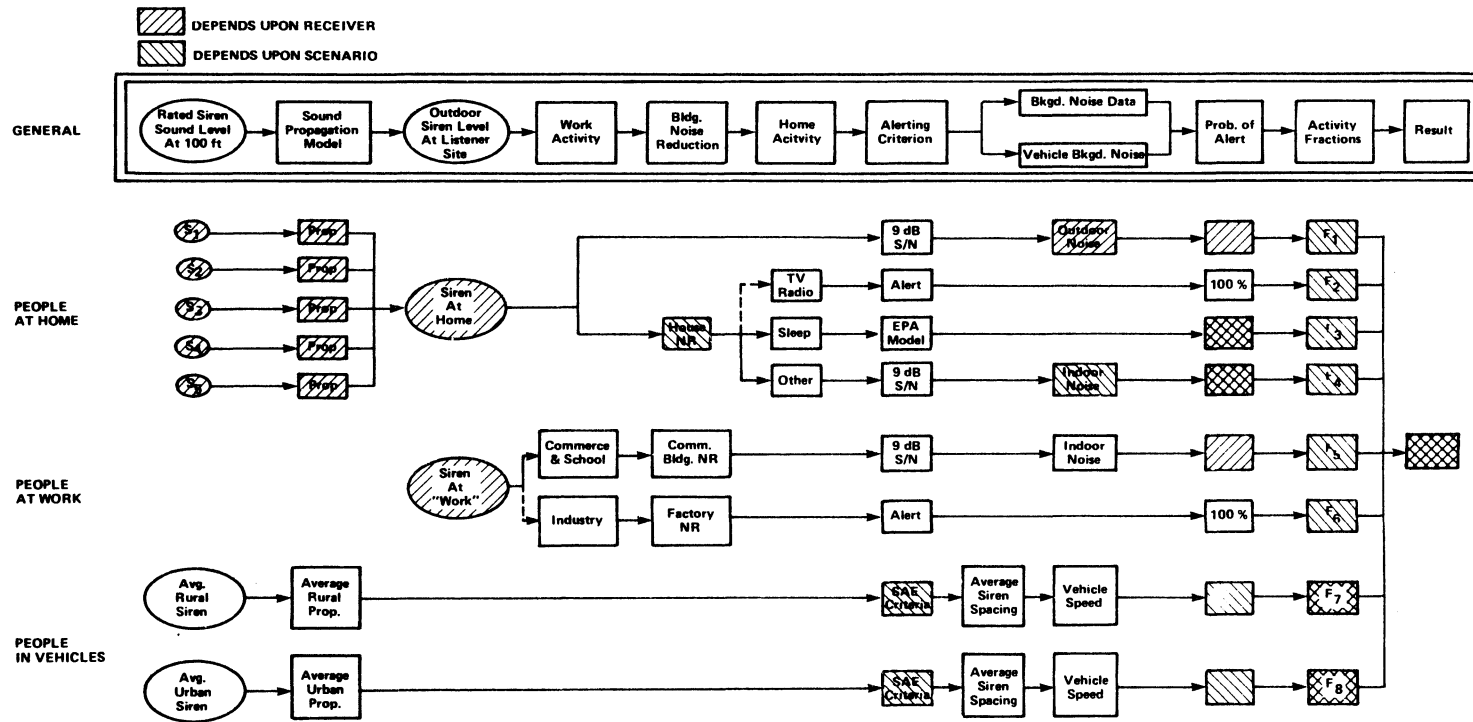

FIG. 3-1. FLOW OF COMPUTATIONS.

(S/N) difference in the 630-Hz 1/3-octave frequency band. The chosen criterion for alerting is that the given signal level must be 9 dB or more above the minimum background noise level at any time during a 4-minute period for people who are not sleeping (i.e., a S/N difference of 9 dB). The chance of alert while sleeping is based on the indoor siren Single Event Level (SEL) - a measure of total acoustic energy - and the sleep awakening model developed by the U.S. Environmental Protection Agency [5]. The graph used for estimating the chance of alert during sleep is shown in Fig. 3-2; for the Three Mile Island analysis, the curve for the chance of awakening one out of two sleepers was used.

3.4 Alerting People Out of Doors

For the analysis of the ability of sirens to alert people out of doors, background noise levels are based on noise measurements conducted by BBN in the vicinity of the Trojan Nuclear Plant in Oregon, near the Susquehanna Steam Electric Station in Pennsylvania, and upon the body of data in BBN files. The data typically consisted of statistical summaries of background noise at various types of locations. The summaries provide the L_{90} (sound level exceeded 90% of the time) for 1-minute samples of data in the 1/3-octave frequency band centered at 630 Hz.*. The data were used to calculate the chance of detection for various siren levels and signal durations based on the background noise levels and their variability. Generalized types of background noise environments were then established so that all sample listener sites would be included with one of these general categories. In each category, the siren sound level necessary to alert is 9 dB greater than the minimum background noise level that could exist in any 4-minute period (1 minute for rotating sirens), adjusted for the probabil-

*The L_{90} was used as a conservative estimate of the minimum sound level.

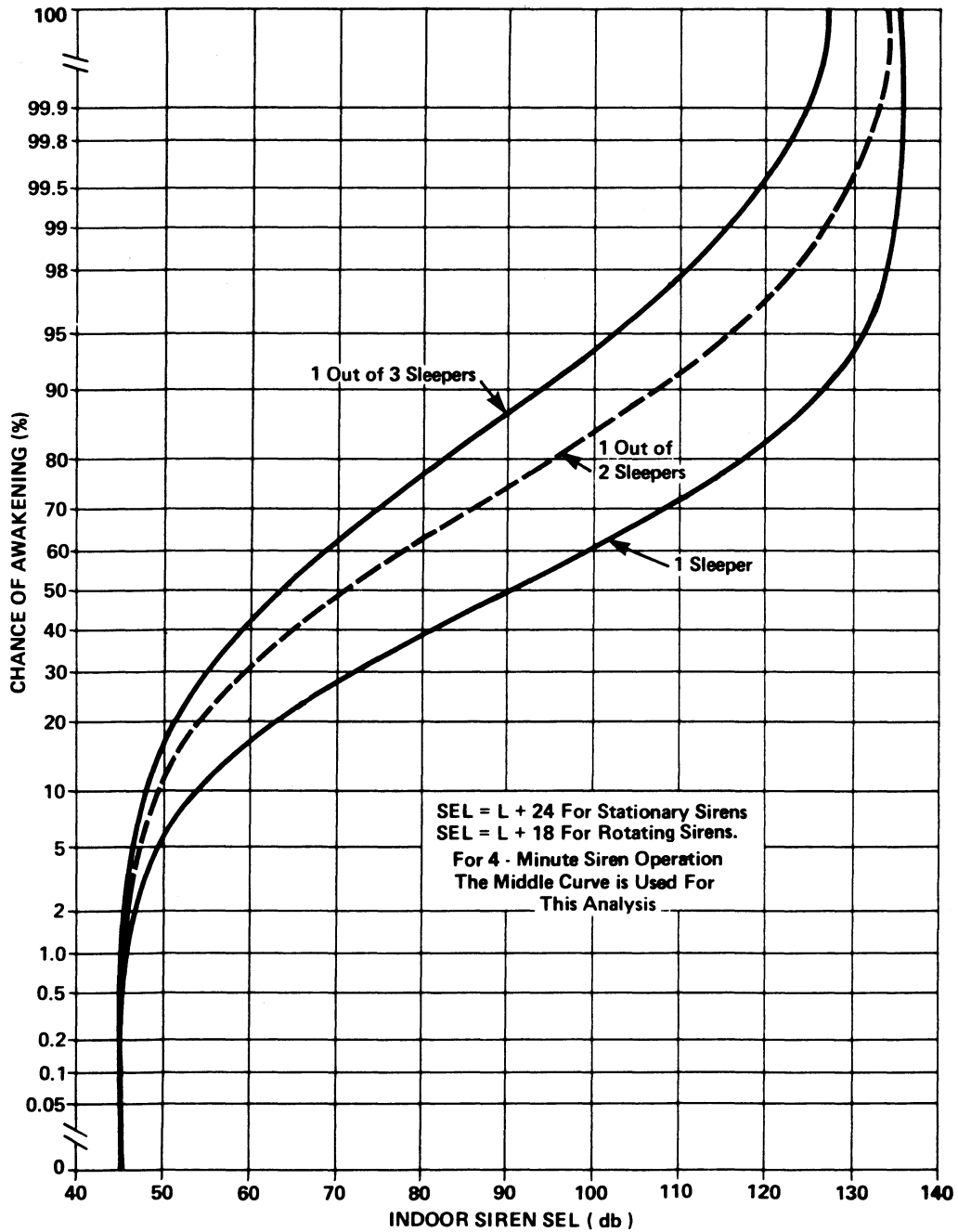

FIG. 3-2. CHANCE OF ALERT FOR AWAKENING PEOPLE ASLEEP.

ity distribution of such minima. This is handled by assigning a "median alerting level" for each background noise category and adjusting these levels in accordance with probability distributions generalized from the data.

The median alerting levels for each background noise category are listed in Table 3.4. These are keyed to corresponding distributions shown in Fig. 3-3. For example, assume that a rotating siren produces 53 dB at a given urban location during the daytime adjacent to a major traffic artery. Table 3.4 indicates that the median alerting level at such locations is 54 dB and that the applicable distribution on Fig. 3-3 is No. 5. The siren level minus the median alerting level is $53 - 54 = -1$ dB. From distribution No. 5 on Fig. 3-3, we read 24% probability of alerting at -1 dB. Note that probabilities of greater than 99% on Fig. 3-3 are treated as 100%, and those less than 1% are treated as 0%.

Outdoor background noise in urban areas and along rural roadways is caused predominantly by motor vehicle traffic. It is generally insensitive to seasons of the year, but varies markedly with time of day. Minor traffic variations (i.e., less than a factor of 2 in traffic volume) have little effect on the background noise.

In rural areas remote from roadways, outdoor background noise can be seasonal (birds, insects, etc.) and can vary with the weather (wind, rain, waterflow, surf). Few people live or work in such "natural" acoustic environments. As shown in Table 3.4, rural, non-roadway background noise is selected to be dependent on windspeed.

Note that results are given separately for stationary sirens and rotating sirens. This is because rotating sirens would actually produce their estimated sound level during about one quarter of the presumed 4-minute operating time at any particular listener

TABLE 3.4. SIREN ALERTING ABILITY FOR GENERALIZED CATEGORIES OF OUTDOOR ENVIRONMENTS.

Generalized Background Noise Environment	Median Alerting Level (dB)		Applicable Distribution ¹	
	Rotating Siren (4 min)	Stationary Siren (4 min)	Rotating Siren (4 min)	Stationary Siren (4 min)
I. URBAN				
A. Roadway				
1. Daytime	54	52	No. 5	No. 3
2. Evening	49	48	No. 4	No. 3
3. Nighttime	43	43	No. 3	No. 2
B. Non-Roadway				
1. Daytime	50	48	No. 5	No. 4
2. Evening	48	47	No. 4	No. 3
3. Nighttime	42	41	No. 3	No. 2
II. RURAL				
A. Roadway				
1. Limited Access Highway ²	63	61	No. 6	No. 4
2. Other Highway ³	51	50	No. 6	No. 4
B. Non-Roadway				
1. No-Wind Noise ⁴	28	27	No. 3	No. 1
2. Subject to Wind Noise ⁵	(See Note)	(See Note)	No. 5	No. 3
III. INDUSTRIAL⁶	55	54	No. 4	No. 2

NOTES:

1. See Fig. 3-3.
2. Alerting levels apply for sites within 500 ft, with view angle (θ) of 180° to highway; beyond 500 ft, levels should be reduced by $10 \log_{10} (D/500)$, where D=dist. from highway in ft; for view angles less than 180° , levels should be further reduced by $10 \log_{10} (180/\theta)$.
3. Alerting levels apply for sites within 1600 ft, with view angle (θ) of 180° to highway; beyond 1600 ft, levels should be reduced by $10 \log_{10} (D/1600)$, where D=dist. from highway in ft; for view angles less than 180° , levels should be further reduced by $10 \log_{10} (180/\theta)$.
4. Wind Speed < 1 mph.
5. Median Alerting Level (with wind) = Median Alerting Level (no wind) + $15 \log_{10}(S) + 1$ dB, where S = average wind speed in mph.
6. Alerting levels apply at 1000 ft from source; for other distances adjust levels by $20 \log_{10} (1000/\text{distance})$.

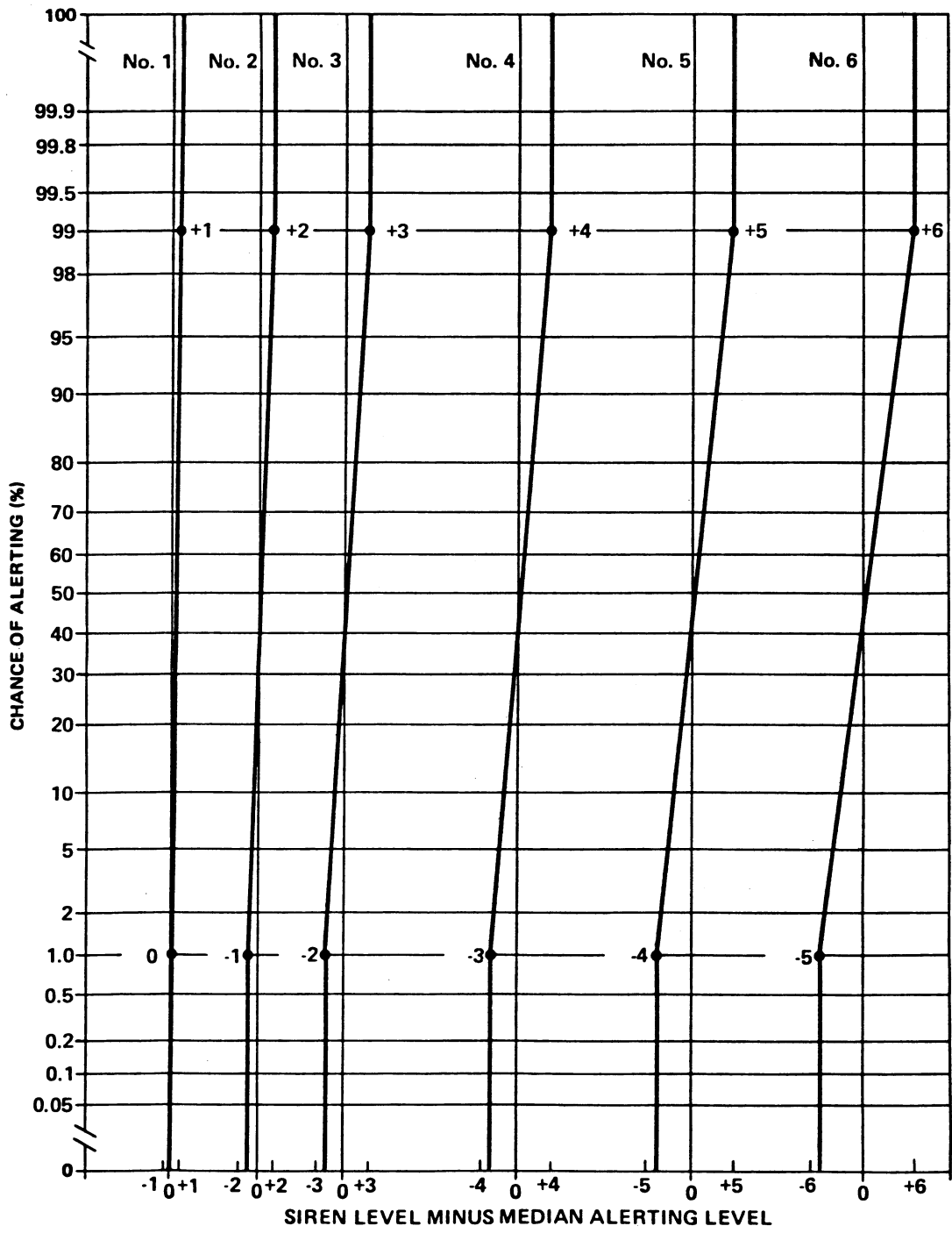

FIG. 3-3. DISTRIBUTIONS FOR DETECTION BY PEOPLE OUT OF DOORS.

location. Thus, the results for rotating sirens are based on 1-minute statistics rather than on 4-minute statistics.

In summary, information regarding siren type, estimated siren sound level, background noise category at the listener site, and test-case conditions are used in conjunction with Table 3.4 and Fig. 3-3 to estimate the chance of siren detection outdoors.

3.5 Alerting People Indoors

For the analysis of alerting people indoors at home, three types of activities are considered. These are (1) listening to radio or TV, (2) sleeping, or (3) other activities that range from quiet to noisy situations. Table 3.5 provides the percentages assumed for various activities for each scenario.

For people listening to radio or TV, the chance of alert is 100%. For people sleeping, the chance of alert is calculated from the indoor siren SEL using the relationship shown in Fig. 3-2 for the chance of awakening one out of two sleepers. For all other indoor activities, the chance of alert is based on classifications of actual indoor background noise measurements under a wide variety of conditions.

Results for test cases 1 and 3 are provided in Fig. 3-4 for 4-minute stationary sirens and in Fig. 3-5 for 4-minute rotating sirens. Thus, given the siren type, indoor siren level, and test case condition, these figures are used to estimate the chance of alerting for indoor activities other than sleeping or listening to radio or TV.

For the analysis of alerting at work, two activity categories are considered: (1) commercial/institutional, and (2) industrial environments. For the TMI analysis, it was assumed that 75% of the working population are in commercial establishments while the

TABLE 3.5. ASSUMED ACTIVITIES AND BACKGROUND NOISE ENVIRONMENTS FOR PEOPLE INDOORS.

Scenario	Percentages of People Engaged in Various Activities Indoors (%)						
	At Place of Business	Listening to TV/Radio	Sleeping	Indoor Noise Environment			
				Obviously Noisy ¹	Busy and Active ²	Isolated ³	Obviously Quiet ⁴
1. Warm Summer Weekday Afternoon (clear to partly cloudy)	41	27	5	--	8	5	14
2. Summer Weekday Night (clear to partly cloudy)	4	--	96	--	--	--	--
3. Winter Weekday During Evening Commuting Hours (cold and overcast)	--	20	--	5	50	20	5
4. Winter Night During Snowfall	5	--	95	--	--	--	--

NOTES:

1. Vacuum cleaning, dishwasher, shower, vent fan on, etc.
2. Dinner conversation, kitchen work, playing music, children at play, etc.
3. Noise-producing activity in adjacent room, soft background music, etc.
4. Reading, study, eating alone.

remaining 25% are in industrial locations. For commercial locations, the chance of alert is based on the statistics of background noise measured in a typical office environment, using Fig. 3-6. For industrial locations, it has been assumed that 100% of the people are likely to be alerted by some means of communication other than sirens.

3.6 Alerting People in Motor Vehicles

The analysis for the alerting of motorists is based on the assumption of an average siren signal strength and spacing throughout the EPZ. The probability that a motorist will pass within the alert range of a siren during its 4-minute operation is estimated as follows:

$$C = \frac{2R+d}{L} \times 100 \text{ (not to exceed 100\%)}$$

where C is the chance of alert (%), R is the maximum alert distance (ft), d is distance traveled in 4 minutes (ft), and L is the average siren spacing (ft). Separate analyses were carried out for urban and rural areas of the TMI EPZ.

The average urban siren produces a sound level of 125 dB at 100 ft, and the average rural siren produces a sound level of 123 dB at 100 ft. Alerting ability was evaluated by using the results of a study for the Society of Automotive Engineers (SAE) [6]. Siren alerting levels for speeds of 55 mph and 30 mph with windows shut or open were first determined from the SAE study results. The average siren source levels for rural and urban areas were

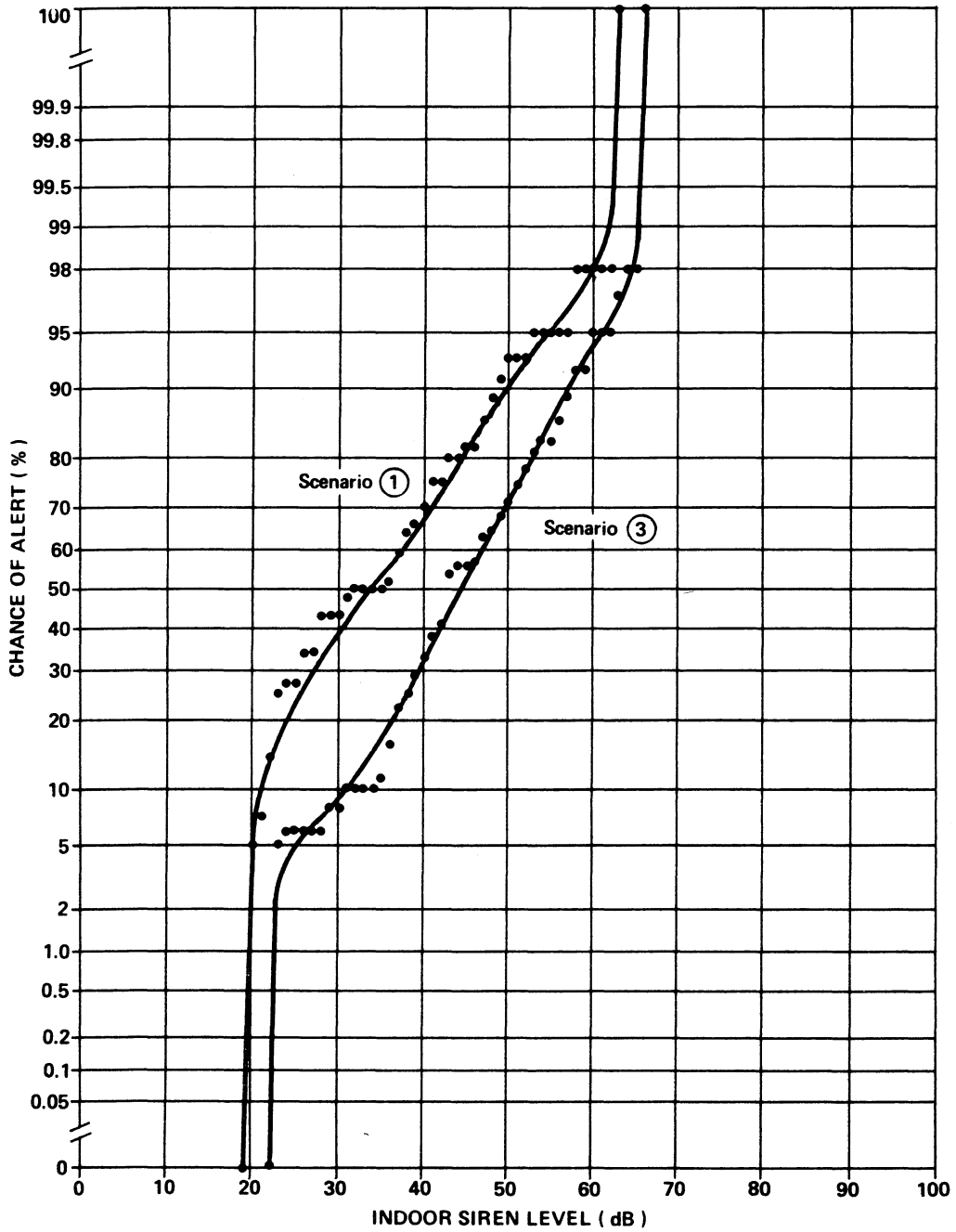

FIG. 3-4. CHANCE OF ALERT FOR PEOPLE INDOORS AT HOME (4-MINUTE STATIONARY SIREN).

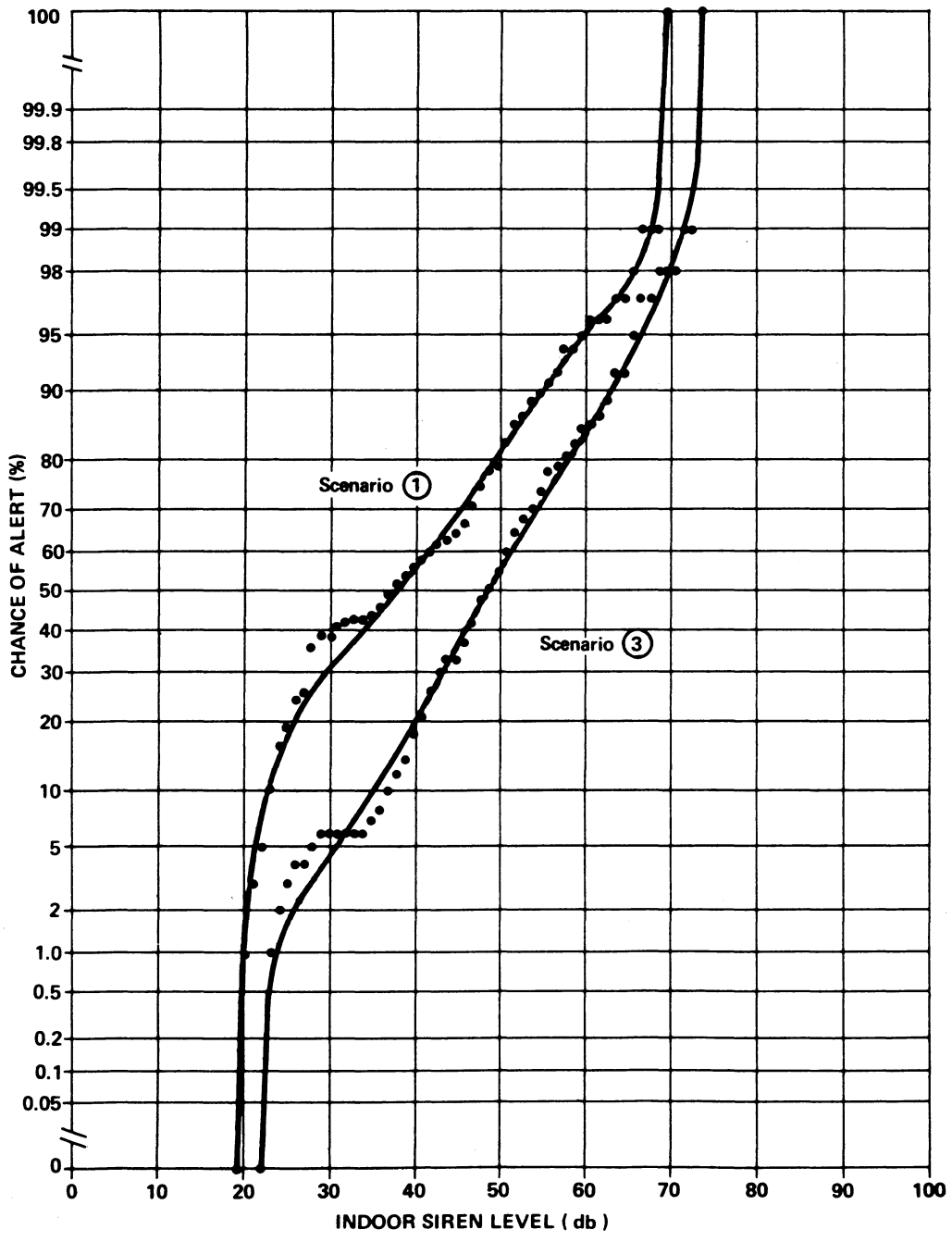

FIG. 3-5. CHANCE OF ALERT FOR PEOPLE INDOORS AT HOME (4-MINUTE ROTATING SIREN).

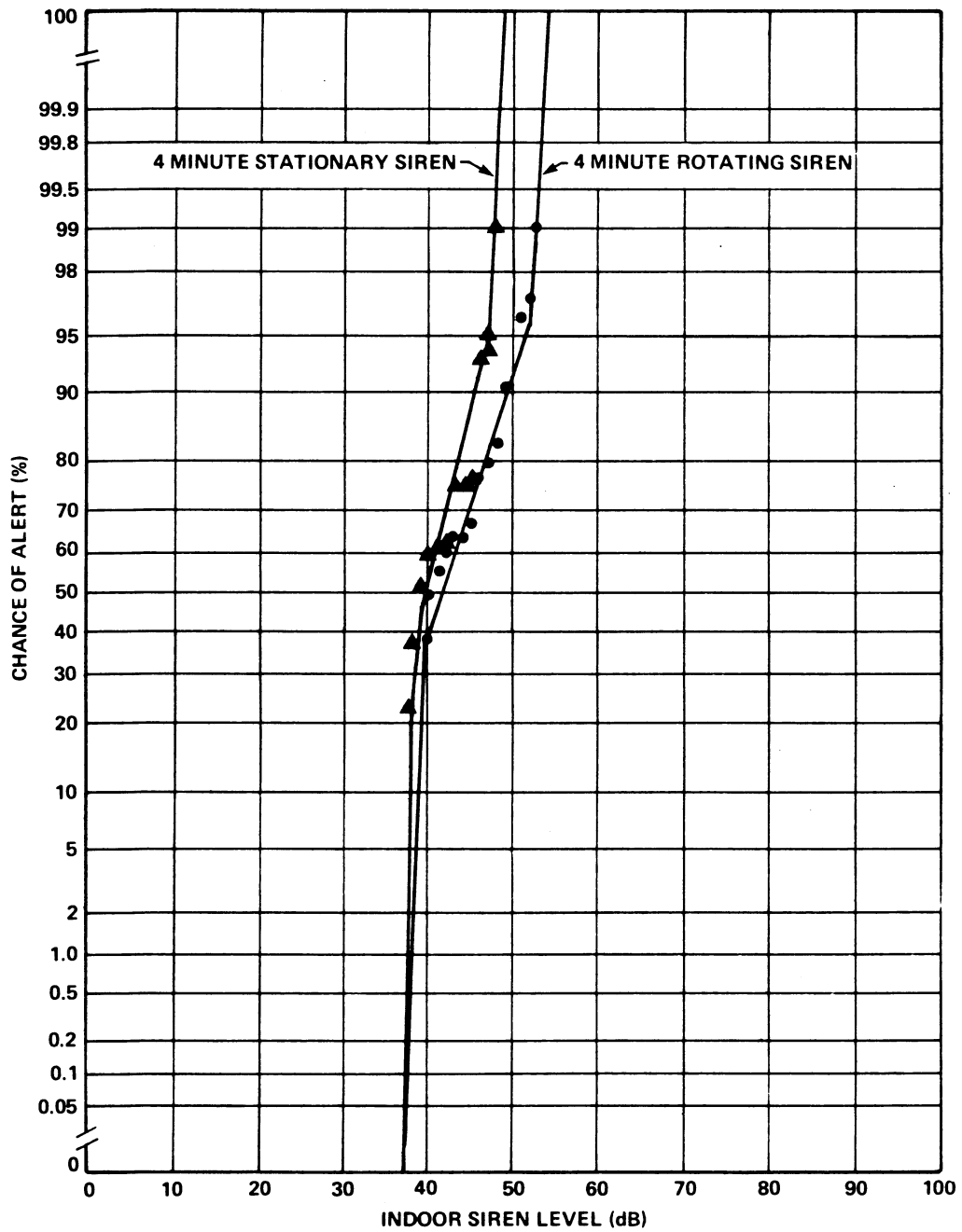

FIG. 3-6. CHANCE OF ALERT FOR PEOPLE INDOORS AT WORK IN COMMERCIAL/INSTITUTIONAL ESTABLISHMENTS.

then reduced to alerting levels in accordance with the propagation models from current NRC guidelines (i.e., 10 dB/double distance) [7]. In this manner, the maximum alert distance (R) was calculated for each driving condition. The distance traveled in 4 minutes (d) was calculated based on speed for each case, and the average siren spacing (L) was estimated to be 5,560 ft for urban areas and 11,850 ft for rural areas.

The calculations of alerting ability for motorists are summarized in Table 3.6. The results indicate that the chance of alert is expected to be 100% for all conditions applicable to the TMI analysis.

TABLE 3.6. SIREN ALERTING FOR MOTORISTS.

Area	Vehicle Speed (mph)	Vehicle Window Condition	Reqd. Signal for Alert (dB)	Max. Alert Dist., R (ft)	4-min Travel dist., d (ft)	Avg. Siren Spacing, L (ft)	Chance of Alert (%)
URBAN	55	closed	96	610	19,360	5560	100
		open	90	920	19,360	5560	100
	30	closed	89	980	10,560	5560	100
		open	86	1210	10,560	5560	100
RURAL	55	closed	96	650	19,360	11,850	100
		open	90	980	19,360	11,850	100
	30	closed	89	1060	10,560	11,850	100
		open	86	1300	10,560	11,850	100

4. EVALUATION OF THE PROMPT ALERTING SYSTEM FOR THE INDIAN POINT NUCLEAR POWER STATION

This section summarizes the evaluation of the siren alerting system for the Indian Point Nuclear Power Station. The procedure that was used consists of a detailed analysis of siren alerting capability at each of 50 randomly chosen listener locations, under four different "sample scenario" conditions. The random selection process for listener sites is described in Appendix J and the four test cases (sample scenarios) are included in Appendix K. The analysis is based on existing and proposed siren locations as of 25 August 1981. Maps which show the siren locations are provided in Appendix L.

The results of the evaluation for Indian Point are summarized in Table 4.1 and indicate that the chance of alert is estimated to vary between 57% and 95% depending on the sample scenario under consideration. The remainder of this report describes the procedure used to arrive at this conclusion. Input and output data for the analysis are included in Appendix M.

4.1 Estimating Siren Sound Levels Out of Doors at Listener Sites

The first step in the procedure is to determine the siren in the vicinity of each selected listener site that is expected to produce the highest sound level at that site for each sample scenario. This choice is not always obvious, because the sound level caused by a particular siren at a given listener site depends not only on the sound output of the siren and its distance from the listener, but also on shielding and atmospheric effects (particularly wind direction). Therefore, it is generally necessary to evaluate several sirens in the vicinity of each listener site in order to determine the dominant one. As a general rule, the closest, highest-rated, nonshielded sirens are selected for evaluation at each site. Furthermore, sirens should be chosen

TABLE 4.1. SUMMARY OF INDIAN POINT SIREN SYSTEM EVALUATION RESULTS.

Scenario		Chance of Alert		
		Urban (%)	Rural (%)	Population-Weighted Average*
No.	Description	(%)	(%)	(%)
1	Warm Summer Weekday Afternoon (clear to partly cloudy)	98	93	95
2	Summer Weekday Night (clear to partly cloudy)	80	70	74
3	Winter Weekday Evening (cold and overcast)	91	78	83
4	Winter Night (during snowfall)	63	53	57

*Based on a total urban population of 110,928 and a total rural population of 146,454.

such that they are distributed north, south, east, and west of the site (or in any other four mutually perpendicular directions) where possible to account for different wind directions. For the Indian Point analysis, four or five sirens were evaluated at each of the 50 listener sites.

The next step in the procedure is to establish the outdoor sound level produced by the selected sirens at each listener location. This is accomplished by applying adjustments to the rated sound level of the siren as follows:

$$L(\text{listener}) = L(\text{siren}) - A_d - A_s - A_{\text{air}} - A_{\text{atm}}$$

where $L(\text{listener})$ is the outdoor siren sound pressure level at the listener site (dB), $L(\text{siren})$ is the rated sound pressure level of the siren at 100 ft (dB), A_d is the distance attenuation (dB), A_s is the shielding attenuation (dB), A_{air} is the air absorption (dB), and A_{atm} is the atmospheric attenuation caused by wind and temperature gradients (dB).

The rated sound pressure level for all of the Indian Point sirens was taken to be 125 dB at a distance of 100 ft, based upon the siren manufacturer's rating; all sirens are rotating type units.

The first two adjustments (for distance and shielding) are the same for all four test cases and are based on information obtained from USGS maps. Distance attenuation beyond 100 ft is calculated by assuming sound propagation from an acoustic point source with a reduction of 6 dB per distance doubled. It is calculated as follows:

$$A_d = 20 \log_{10} \left(\frac{d}{100} \right) ,$$

where d is the siren-to-listener distance (ft).

Shielding attenuation (A_S) is estimated using the following formula for the attenuation of a rigid straight barrier for sound incident from a point source [2]:

$$A_S = \begin{cases} 20 \log \frac{\sqrt{2\pi N}}{\tanh \sqrt{2\pi N}} + 5 \text{ dB} & \text{for } N > -0.2 \\ 0 \text{ dB} & \text{for } N < -0.2 \end{cases}$$

N is the Fresnel number (dimensionless):

$$N = \frac{2}{\lambda} (A + B - d)$$

Where λ = wavelength of sound, ft (1.79 ft for 630-Hz siren tone)

d = straight-line distance between source and receiver, ft

$A + B$ = shortest path length of wave travel over the barrier between source and receiver, ft

+ sign = receiver in the shadow zone (i.e., barrier obstructs line-of-sight)

- sign = receiver in the bright zone (i.e., barrier doesn't obstruct line-of-sight)

When N is negative, the above equation for A_S is evaluated by replacing N with $|N|$, and by replacing \tanh with \tan .

Shielding attenuation is limited to a maximum of 24 dB based upon a large body of experimental data. For the Indian Point analysis, sirens are assumed to be at a height of 52 ft above terrain level, listener sites are assumed to be at a height of 5 ft above terrain level, and barrier heights are obtained from ground contour information on USGS maps.

The adjustments for air absorption and atmospheric effects depend on the meteorological conditions for the particular scenario. The assumed conditions for the Indian Point site are

provided in Table 4.2 for the four test cases, based on local weather information.* In terms of air absorption, these conditions indicate the following attenuation rates based upon temperature and relative humidity [3].

Scenario	A_{air} (dB per 1000 ft)
1	0.85
2	0.81
3	0.49
4	0.46

The adjustment for atmospheric gradient effects (A_{atm}) is based on siren-to-listener azimuth with respect to wind direction and on wind and temperature gradient characteristics. Table 4.3 summarizes the calculation procedure for determining A_{atm} for each scenario at the Indian Point site. A more detailed description of the estimation procedure for A_{atm} can be found in Appendix D.

Application of the above calculations yields the estimated outdoor sound pressure level for various sirens at each sample listener site, for each of the four scenarios. For the balance of the analysis, only the highest siren level at each listener site is used.

4.2 Estimating Indoor Sound Levels of Sirens

The result of the above calculations is a single outdoor siren sound pressure level at each of the 50 sample listener locations for each of the four test cases. Corresponding indoor

*Final Facility Description and Safety Analysis Report for Indian Point No. 3 Nuclear Power Plant, Section 2.6 (1973).

TABLE 4.2. METEOROLOGICAL CONDITIONS FOR THE FOUR SAMPLE SCENARIOS USED TO EVALUATE THE INDIAN POINT SIREN SYSTEM.

Scenario No.	Wind Conditions*	Temperature Gradient	Relative Humidity (%)	Temperature (°F)
1	10 mph from the SSE; from the south in the river valley	-1.0°F/100 ft Class A	65	80
2	6 mph from the NNE; from the north in the river valley	+0.5°F/100 ft Class E	80	70
3	10 mph from the northwest	-0.5°F/100 ft Class D	70	30
4	15 mph from the southeast	-0.5°F/100 ft Class D	90	30

*At 100 ft above ground level.

TABLE 4.3. CALCULATION OF ATMOSPHERIC ATTENUATION, A_{atm} , CAUSED BY WIND AND TEMPERATURE GRADIENTS (SEE APPENDIX D FOR DETAILS).

Siren-to-Listener Distance, D (Ft) Relative to X_0 (Ft)	A_{atm} (dB)			
$D \leq 1.2 X_0$	0			
$1.2 X_0 < D \leq 1.7 X_0$	5			
$1.7 X_0 < D \leq 2.4 X_0$	10			
$2.4 X_0 < D \leq 3.4 X_0$	15			
$3.4 X_0 < D$	20			

Computation of X_0				
Scenario	<u>1</u>	<u>2</u>	<u>3</u>	<u>4</u>
Wind Direction, θ_w				
General	157.5°	22.5°	315°	135°
Valley	0°	180°	-	-
$\Delta T^\circ F$ (95'-7')	-0.9	+0.44	-0.44	-0.44
$a = \alpha z = \Delta T / \ln 95' - \ln 7'$	-0.35	+0.17	-0.17	-0.17
Wind Speed, V_2 ft/sec@100ft	14.7	8.8	14.7	22
$z\beta = V_2 / (\ln 100' - \ln 2')$	3.75	2.25	3.75	5.62
R/S	0.1			
f(R/S)	0.45			
X_0 (min) @ $\phi = 0$	522'	633'	534'	439'
$\phi_c = \cos^{-1} \left(\frac{\alpha}{\beta} \right)$	95°	85°	93°	92°

levels are then obtained by subtracting typical values for commercial or residential building sound attenuation. For test cases 1 and 2 (summer), residential windows were assumed to be partly open; for test cases 3 and 4 (winter) residential windows were assumed to be closed (with storm windows). For the frequency region within the 500 Hz octave band, the sound attenuation into buildings is estimated to be 16 dB for test cases 1 and 2 and 31 dB for test cases 3 and 4 [4]. For commercial buildings, the outdoor-to-indoor noise reduction is estimated to be 31 dB, assuming closed and sealed windows for all four scenarios.

4.3 Assumptions about Chance of Alert

The outdoor and indoor siren levels calculated by the above procedure provide some of the information required for the analysis of the chance of alert. In addition, it is necessary to know the level of interfering background noise at the listener locations.

Figure 4-1 is a flow chart of the analysis computations. The analysis is divided into components (rows) that correspond to the possible activities of people for the various scenarios. The major components relate to people (1) at home (outside or inside), (2) at work, or (3) in motor vehicles. The chance of alert is estimated for each activity component and is then multiplied by the fraction of people likely to be engaged in that activity (activity fraction). The results are summed to obtain the overall chance of alert for each listener location and for each test case. Overall chances of alert for the various scenario (test case) conditions are then obtained by averaging the chances for all rural and/or urban sample listener sites. Note that all estimates assume siren signal duration of 4 minutes: an

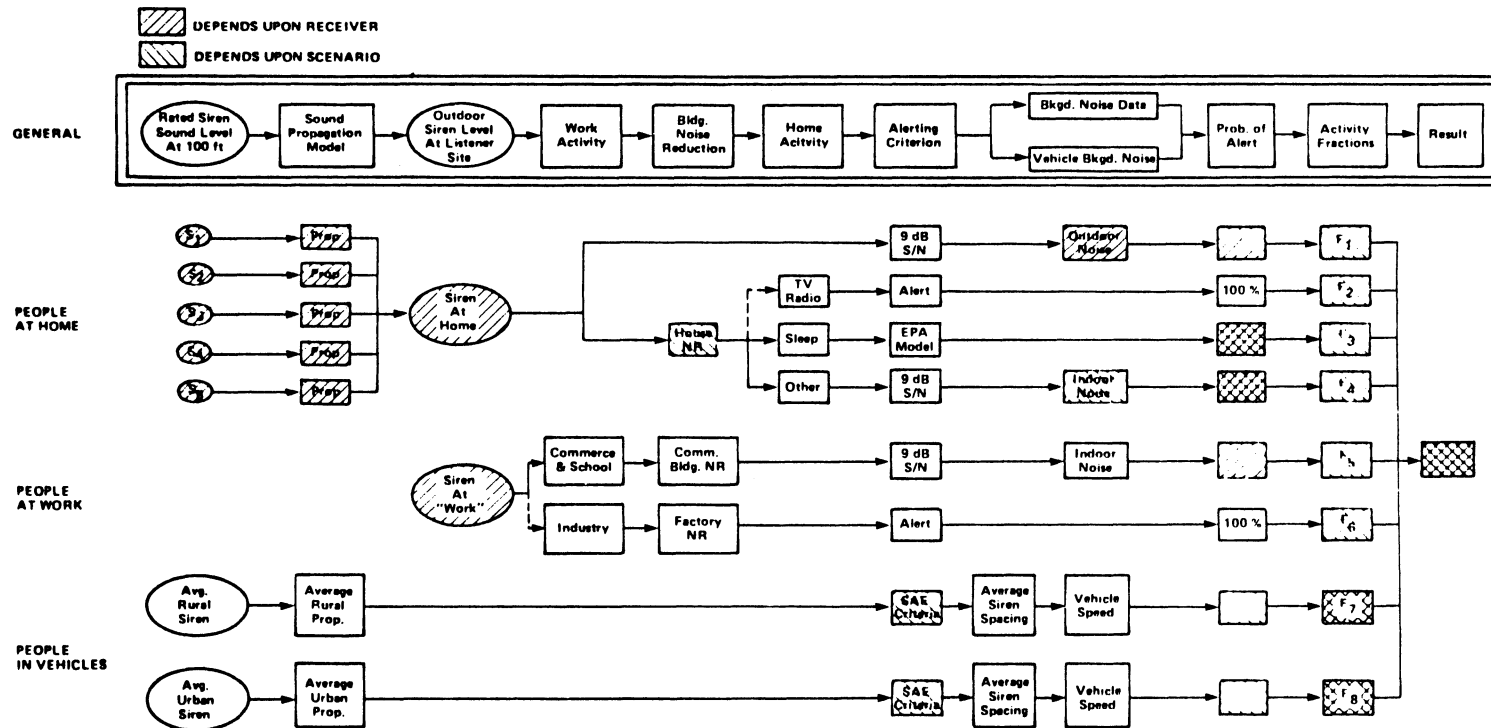

FIG. 4-1. FLOW OF COMPUTATIONS.

average of the "3 to 5 minutes" called for in Appendix 3 of NUREG-0654. The effects of different siren signal durations are discussed in Appendix E.

Siren detectability is a function of the siren signal level and of the background noise level in a "critical frequency band" centered at the signal frequency. For this analysis, outdoor and indoor detectability is estimated based on the signal-to-noise (S/N) difference in the 630-Hz 1/3-octave frequency band. The chosen criterion for alerting is that the given signal level must be 9 dB or more above the minimum background noise level at any time during a 4-minute period for people who are not sleeping (i.e., a S/N difference of 9 dB). The chance of alert while sleeping is based on the indoor siren Single Event Level (SEL) - a measure of total acoustic energy - and the sleep-awakening model developed by the U.S. Environmental Protection Agency [5]. The graph used for estimating the chance of alert during sleep is shown in Fig. 4-2; for the Indian Point analysis, the curve for the chance of awakening one out of two sleepers was used.

4.4 Alerting People Out of Doors

For the analysis of the ability of sirens to alert people out of doors, background noise levels are based on noise measurements conducted by BBN in the vicinity of the Trojan Nuclear Plant in Oregon, near the Indian Point Nuclear Power Station in New York, and upon the body of data in BBN files. The data typically consisted of statistical summaries of background noise at various types of locations. The summaries provide the L_{90} (sound level exceeded 90% of the time) for 1-minute samples of data in the 1/3-octave frequency band centered at 630 Hz.*

*The L_{90} was used as a conservative estimate of the minimum sound level.

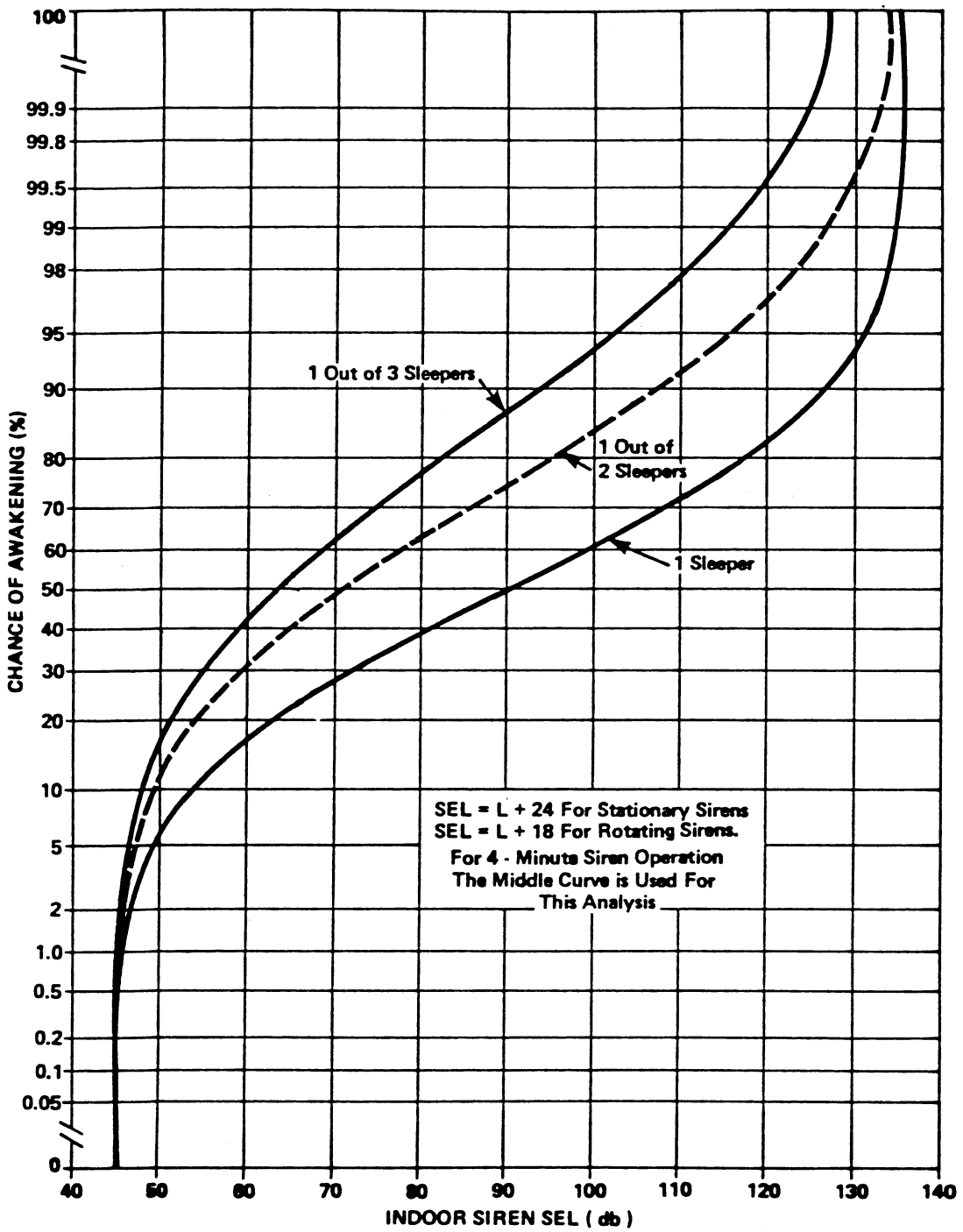

FIG. 4-2. CHANCE OF ALERT FOR AWAKENING PEOPLE ASLEEP.

These data were used to estimate the range of background noise levels that are likely to exist during any 4-minute period (1 minute for rotating sirens) for a variety of outdoor environments. The results are summarized in Table 4.4, which specifies the background noise environment for urban and rural areas. Only daytime noise levels are presented since the nighttime scenarios assume that essentially no people are outdoors at night. The siren sound level necessary to alert is 9 dB greater than the minimum background noise level that could exist in any 4-minute period (1 minute for rotating sirens), adjusted for the probability distribution of such minima. The chance of alert for people outdoors was determined for each scenario at each listener site using Figure 4-3.

Outdoor background noise in urban areas and along rural roadways is caused predominantly by motor vehicle traffic. It is generally insensitive to seasons of the year, but varies markedly with time of day. Minor traffic variations (i.e., less than a factor of 2 in traffic volume) have little effect on the background noise.

In rural areas remote from roadways, outdoor background noise can be seasonal (birds, insects, etc.) and can vary with the weather (wind, rain, waterflow, surf). Few people live or work in such "natural" acoustic environments.

Note that rotating sirens would actually produce their estimated sound level during about one quarter of the presumed 4-minute operating time at any particular listener location. Thus, the results for rotating sirens are based on 1-minute statistics rather than on 4-minute statistics.

TABLE 4.4. MINIMUM BACKGROUND NOISE LEVELS FOR GENERALIZED CATEGORIES OF OUTDOOR ENVIRONMENTS (SEE FIG. 4-3 FOR DISTRIBUTIONS).

Generalized Background Noise Environment	Range of Minimum Background Noise Levels for a 1-Minute Period ^{1,2} (dB)
I. URBAN-DAY ³ (Includes Rural locations within 1000 ft. of major roadways)	21-57
II. RURAL-DAY ⁴ (Except Rural locations within 1000 ft. of major roadways)	17-48

NOTES:

1. Refers to the range of the minimum (L₉₀) sound pressure levels in the 630 Hz one-third octave band during the specified time period.
2. Applicable for analysis of rotating sirens operated for 4 minutes.
3. Urban locations are defined as the pink "building exclusion" areas of topographic maps, or as those communities with a population density exceeding 2000 people per square mile. Major roadways are defined as roadways with more than one lane in each direction.
4. Rural locations are taken to be all sites not classified as urban (above).

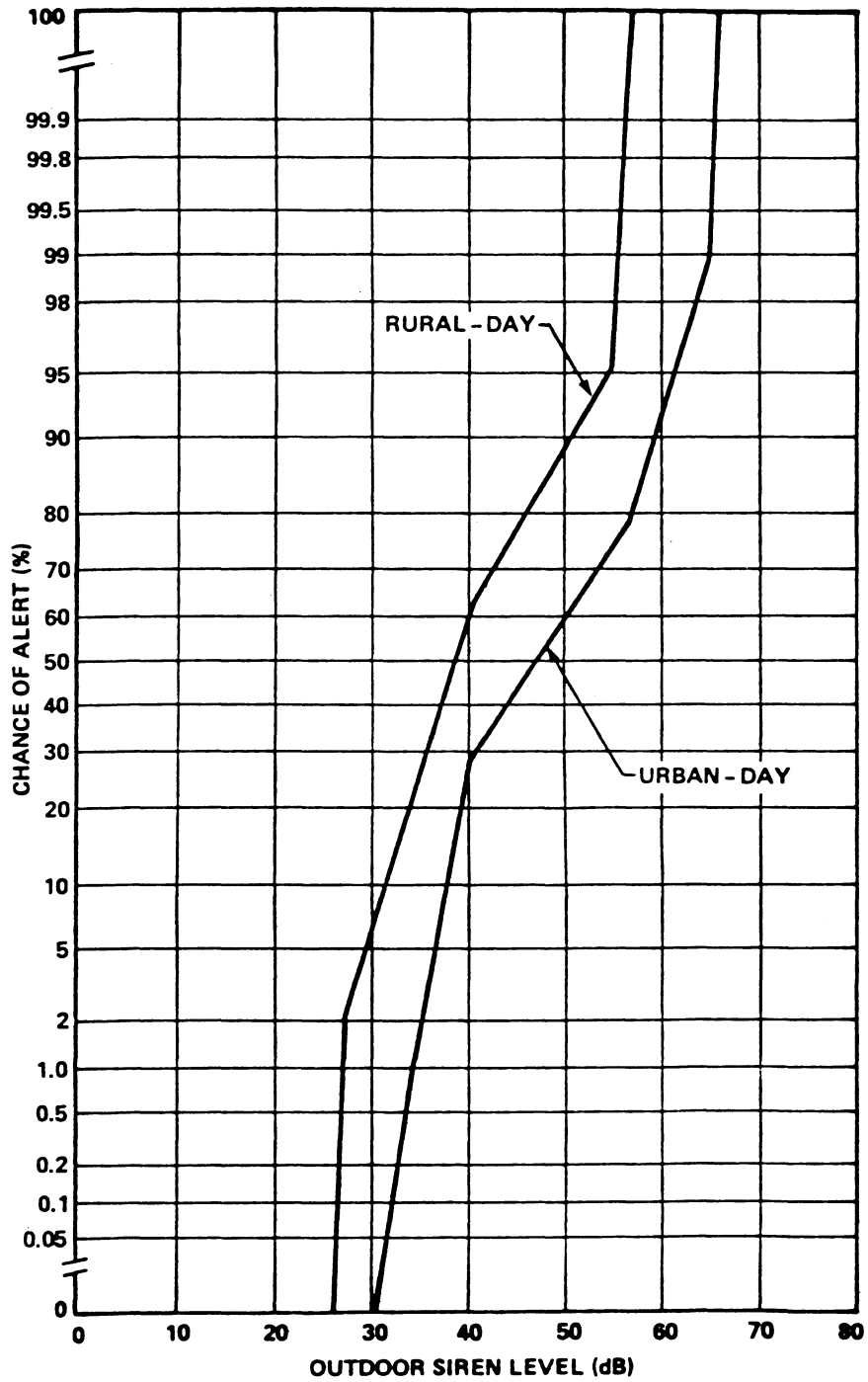

FIG. 4-3. CHANCE OF ALERT FOR PEOPLE INDOORS (4-MINUTE ROTATING SIREN).

4.5 Alerting People Indoors

For the analysis of alerting people indoors at home, three types of activities are considered. These are (1) listening to radio or TV, (2) sleeping, or (3) other activities that range from quiet to noisy situations. Table 4.5 provides the percentages assumed for various activities for each scenario.

For people listening to radio or TV, the chance of alert is 100%. For people sleeping, the chance of alert is calculated from the indoor siren SEL using the relationship shown in Fig. 4-2 for the chance of awakening one out of two sleepers. For all other indoor activities, the chance of alert is based on classifications of actual indoor background noise measurements under a wide variety of conditions.

Results for test cases 1 and 3 are provided in Fig. 4-4 for 4-minute rotating sirens. Thus, given the indoor siren level and test case condition, this figure was used to estimate the chance of alerting for indoor activities other than sleeping or listening to radio or TV.

For the analysis of alerting at work, two activity categories are considered: (1) commercial/institutional, and (2) industrial environments. For the Indian Point analysis, it was assumed that 75% of the working population are in commercial establishments while the remaining 25% are in industrial locations. For commercial locations, the chance of alert is based on the statistics of background noise measured in a typical office environment, using Fig. 4-5. For industrial locations, it has been assumed that 100% of the people are likely to be alerted by some means of communication other than sirens.

TABLE 4.5. ASSUMED ACTIVITIES AND BACKGROUND NOISE ENVIRONMENTS FOR PEOPLE INDOORS.

Scenario	Percentages of People Engaged in Various Activities Indoors (%)						
	At Place of Business	Listening to TV/Radio	Sleeping	Indoor Noise Environment			
				Obviously Noisy ¹	Busy and Active ²	Isolated ³	Obviously Quiet ⁴
1. Warm Summer Weekday Afternoon (clear to partly cloudy)	41	27	5	--	8	5	14
2. Summer Weekday Night (clear to partly cloudy)	4	--	96	--	--	--	--
3. Winter Weekday During Evening Commuting Hours (cold and overcast)	--	20	--	5	50	20	5
4. Winter Night During Snowfall	5	--	95	--	--	--	--

NOTES:

1. Vacuum cleaning, dishwasher, shower, vent fan on, etc.
2. Dinner conversation, kitchen work, playing music, children at play, etc.
3. Noise-producing activity in adjacent room, soft background music, etc.
4. Reading, study, eating alone.

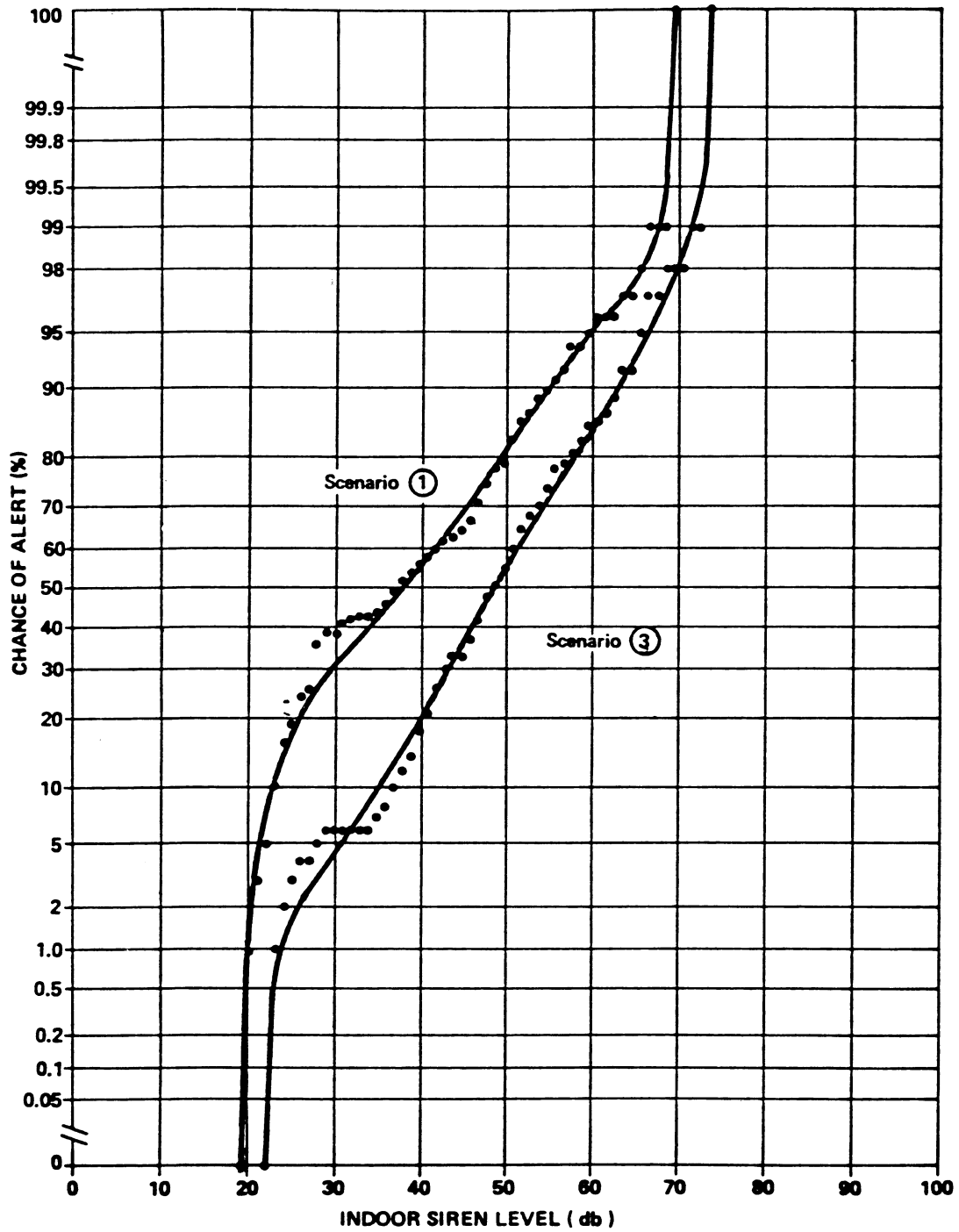

FIG. 4-4. CHANCE OF ALERT FOR PEOPLE INDOORS AT HOME (4-MINUTE ROTATING SIREN).

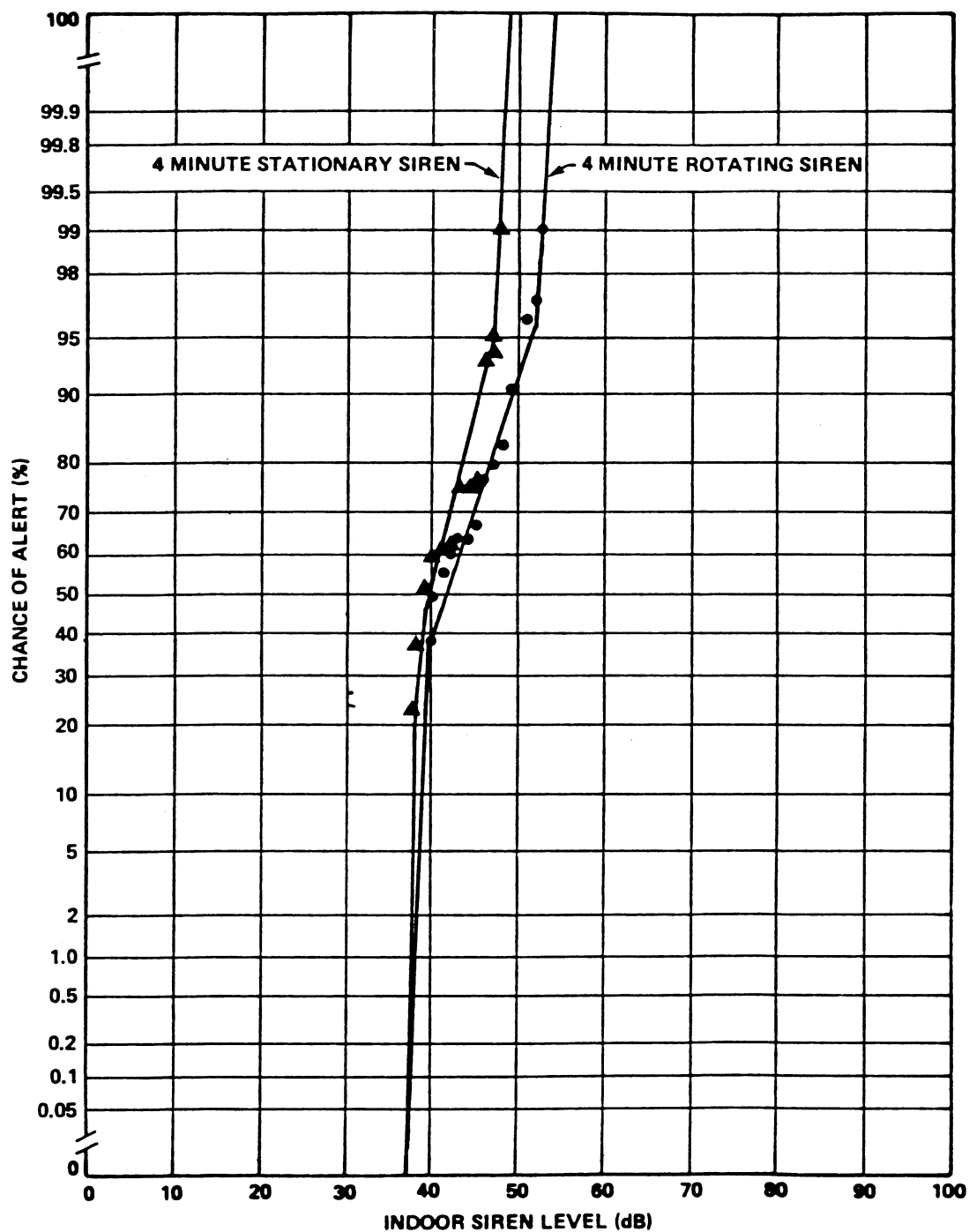

FIG. 4-5. CHANCE OF ALERT FOR PEOPLE INDOORS AT WORK IN COMMERCIAL/INSTITUTIONAL ESTABLISHMENTS.

4.6 Alerting People in Motor Vehicles

The analysis for the alerting of motorists is based on the assumption of an average siren signal strength and spacing throughout the EPZ. The chance that a motorist will pass within the alert range of a siren during its 4-minute operation is estimated as follows:

$$C = \frac{2R+d}{L} \times 100 \text{ (not to exceed 100\%)}$$

where C is the chance of alert (%), R is the maximum alert distance (ft), d is distance traveled in 4 minutes (ft), and L is the average siren spacing (ft). Separate analyses were carried out for urban and rural areas of the Indian Point EPZ.

The average urban or rural siren produces a sound level of 125 dB at 100 ft. Alerting ability was evaluating by using the results of a study for the Society of Automotive Engineers (SAE). [6]. Siren alerting levels for speeds of 55 mph and 30 mph with windows shut or open were first determined from the SAE study results. The average siren source levels for rural and urban areas were then reduced to alerting levels in accordance with the propagation models from current NRC guidelines (i.e., 10 dB/double distance) [7]. In this manner, the maximum alert distance (R) was calculated for each driving condition. The distance traveled in 4 minutes (d) was calculated based on speed for each case, and the average siren spacing (L) was estimated to be 4,890 ft for urban areas and 12,530 ft for rural areas.

The calculations of alerting ability for motorists are summarized in Table 4.6. The results indicate that the chance of alert is expected to be 100% for all conditions applicable to the Indian Point analysis.

TABLE 4.6. SIREN ALERTING FOR MOTORISTS.

Area	Vehicle Speed (mph)	Vehicle Window Condition	Reqd. Signal for Alert (dB)	Max. Alert Dist. R (ft)	4-min Travel Dist., d (ft)	Avg. Siren Spacing L (ft)	Chance of Alert (%)
URBAN	30	Closed	89	980	10,560	4,890	100
		Open	86	1,210	10,560	4,890	100
RURAL	55	Closed	96	650	19,360	12,530	100
		Open	90	980	19,360	12,530	100

5. EVALUATION OF THE PROMPT ALERTING SYSTEM FOR THE ZION NUCLEAR POWER STATION

This section summarizes the evaluation of the siren alerting system for the Zion Nuclear Power Station. The procedure that was used consists of a detailed analysis of siren alerting capability at each of 50 randomly chosen listener locations, under four different "sample scenario" conditions. The random selection process for listener sites is described in Appendix N and the four test cases (sample scenarios) are included in Appendix O. The analysis is based on existing and proposed siren locations as of 15 October 1981. Maps which show the siren locations are provided in Appendix P.

The results of the evaluation for Zion are summarized in Table 5.1 and indicate that the chance of alert is estimated to vary between 58% and 97% depending on the sample scenario under consideration. The remainder of this report describes the procedure used to arrive at this conclusion. Input and output data for the analyses are included in Appendix Q.

5.1 Estimating Siren Sound Levels Out of Doors at Listener Sites

The first step in the procedure is to determine the siren in the vicinity of each selected listener site that is expected to produce the highest sound level at that site for each sample scenario. This choice is not always obvious, because the sound level caused by a particular siren at a given listener site depends not only on the sound output of the siren and its distance from the listener, but also on shielding and atmospheric effects (particularly wind direction). Therefore, it is generally necessary to evaluate several sirens in the vicinity of each listener site in order to determine the dominant one. As a general rule, the closest, highest-rated, nonshielded sirens are selected for evaluation at each site. Furthermore, sirens should be chosen

TABLE 5.1. SUMMARY OF ZION SIREN SYSTEM EVALUATION RESULTS.

Scenario		Chance of Alert		
		Urban (%)	Rural (%)	Population-Weighted Average*
No.	Description	(%)	(%)	(%)
1	Warm Summer Weekday Afternoon (clear to partly cloudy)	97	96	97
2	Summer Weekday Night (clear to partly cloudy)	81	74	80
3	Winter Weekday Evening (cold, overcast, light precipitation)	90	85	89
4	Winter Night (windy)	59	51	58

*Based on a total urban population of 268,629 and a total rural population of 33,201.

such that they are distributed north, south, east, and west of the site (or in any other four mutually perpendicular directions) where possible to account for different wind directions. For the Zion analysis, four or five sirens were evaluated at 46 of the 50 listener sites. Only two or three sirens were considered at the remaining four sites; these sites were located at the fringe of siren coverage such that sirens were not present in all directions.

The next step in the procedure is to establish the outdoor sound level produced by the selected sirens at each listener location. This is accomplished by applying adjustments to the rated sound level of the siren as follows:

$$L(\text{listener}) = L(\text{siren}) - A_d - A_s - A_{\text{air}} - A_{\text{atm}}$$

where $L(\text{listener})$ is the outdoor siren sound pressure level at the listener site (dB), $L(\text{siren})$ is the rated sound pressure level of the siren at 100 ft (dB), A_d is the distance attenuation (dB), A_s is the shielding attenuation (dB), A_{air} is the air absorption (dB), and A_{atm} is the atmospheric attenuation caused by wind and temperature gradients (dB).

The rated sound pressure levels for all the proposed Zion sirens were obtained based on information provided by Commonwealth Edison, and are as follows:

- ACA Dual-Tone Rotating Sirens = 123 dBC @ 100 ft
- ACA Single-Tone Rotating Sirens = 126 dBC @ 100 ft
- Whelen Electronic Rotating Sirens = 124 dBC @ 100 ft
- ACA Stationary Sirens = 115 dBC @ 100 ft

The rated sound pressure levels for existing sirens to be employed in the Zion system were taken to be 125 dBC for rotating

units and 115 dBC or 100 dBC for stationary units, all at a distance of 100 ft.

The first two adjustments (for distance and shielding) are the same for all four test cases and are based on information obtained from USGS maps. Distance attenuation beyond 100 ft is calculated by assuming sound propagation from an acoustic point source with a reduction of 6 dB per distance doubled. It is calculated as follows:

$$A_d = 20 \log_{10} \left(\frac{d}{100} \right) ,$$

where d is the siren-to-listener distance (ft).

Shielding attenuation (A_s) is estimated using the following formula for the attenuation of a rigid straight barrier for sound incident from a point source [2]:

$$A_s = \begin{cases} 20 \log \frac{\sqrt{2\pi N}}{\tanh \sqrt{2\pi N}} + 5 \text{ dB} & \text{for } N > -0.2 \\ 0 \text{ dB} & \text{for } N < -0.2 \end{cases}$$

N is the Fresnel number (dimensionless):

$$N = \pm \frac{2}{\lambda} (A + B - d)$$

where λ = wavelength of sound, ft (1.79 ft for 630-Hz siren tone)

d = straight-line distance between source and receiver, ft

$A + B$ = shortest path length of wave travel over the barrier between source and receiver, ft

+ sign = receiver in the shadow zone (i.e., barrier obstructs line-of-sight)

- sign = receiver in the bright zone (i.e., barrier doesn't obstruct line-of-sight)

When N is negative, the above equation for A_g is evaluated by replacing N with $|N|$, and by replacing \tanh with \tan .

Shielding attenuation is limited to a maximum of 24 dB based upon a large body of experimental data. For the Zion analysis, sirens are assumed to be at a height of 25-60 ft above terrain level, listener sites are assumed to be at a height of 5 ft above terrain level, and barrier heights are obtained from ground contour information on USGS maps.

The adjustments for air absorption and atmospheric effects depend on the meteorological conditions for the particular scenario. The assumed conditions for the Zion site are provided in Table 5.2 for the four test cases, based on local weather information.* In terms of air absorption, these conditions indicate the following attenuation rates based upon temperature and relative humidity [2,3]:

Scenario	A_{air} (dB per 1000 ft)
1	0.85
2	0.85
3	1.0
4	2.0

The adjustment for atmospheric gradient effects (A_{atm}) is based on siren-to-listener azimuth with respect to wind direction and on wind and temperature gradient characteristics. Table 5.3 summarizes the calculation procedure for determining A_{atm} for each scenario at the Zion site. A more detailed description of the estimation procedure for A_{atm} can be found in Appendix D.

*Commonwealth Edison, Zion Nuclear Power Station Weather Data Records.

TABLE 5.2. METEOROLOGICAL CONDITIONS FOR THE FOUR SAMPLE SCENARIOS USED TO EVALUATE THE ZION SIREN SYSTEM.

Scenario No.	Wind Conditions*	Temperature Gradient	Relative Humidity (%)	Temperature (°F)
1	11 mph from the southeast	-1.3°F/90 ft	60	71
2	12 mph from the WNW	+1.1°F/90 ft	60	70
3	11 mph from the NNW	-0.7°F/90 ft	95	17
4	33 mph from the WSW	-0.8°F/90 ft	76	13

*At 125 ft above ground level.

TABLE 5.3. CALCULATION OF ATMOSPHERIC ATTENUATION, A_{atm} , CAUSED BY WIND AND TEMPERATURE GRADIENTS (SEE APPENDIX D FOR DETAILS).

Siren-to-Listener Distance, D (Ft) Relative to X_0 (Ft)	A_{atm} (dB)			
$D \leq 1.2 X_0$	0			
$1.2 X_0 < D \leq 1.7 X_0$	5			
$1.7 X_0 < D \leq 2.4 X_0$	10			
$2.4 X_0 < D \leq 3.4 X_0$	15			
$3.4 X_0 < D$	20			

Computation of X_0

$$X_0 \approx \frac{47S}{\sqrt{C}} \cdot f\left(\frac{R}{S}\right) - 1057/\sqrt{z\beta \cos\phi} - a$$

<u>Scenario</u>	<u>1</u>	<u>2</u>	<u>3</u>	<u>4</u>
Wind Direction, θ_w	130°	290°	328°	251°
$\Delta T^\circ F$ (125'-35')	-1.3	+1.1	-0.7	-0.8
$a = \alpha z = \Delta T / (\ln 125' - \ln 35')$	-1.02	+0.86	-0.55	-0.63
Wind Speed, V_2 ft/sec @ 125ft	16.3	17.2	15.8	48.4
V_1 ft/sec @ 35ft	10.1	8.9	11.6	32.3
$z\beta = (V_2 - V_1) / (\ln 125' - \ln 35')$	4.87	6.52	1.27	12.65
R/S	0.1			
f(R/S)	0.45			
X_0 (min) @ $\phi = 0$	436'	444'	784'	290'
$\phi_c = \cos^{-1} \left(\frac{\alpha}{\beta}\right)$	102°	82°	116°	93°

Application of the above calculations yields the estimated outdoor sound pressure level for various sirens at each sample listener site, for each of the four scenarios. For the balance of the analysis, only the highest siren level at each listener site is generally used. An exception to this rule is made at listener sites where the sound level of a stationary siren is estimated to be between 0 and 6 dB lower than the sound level of a rotating-type siren which had been determined to be the loudest siren. In such cases, the stationary siren was selected for further analysis. The reason for this exception is that the maximum sound level produced by a rotating siren is not continuous, and thus the total acoustic energy at the listener (as measured by the single event noise exposure level, or SEL) is approximately 6 dB less than for a stationary (i.e., continuous) siren with the same maximum sound level.

5.2 Estimating Indoor Sound Levels of Sirens

The result of the above calculations is a single outdoor siren sound pressure level at each of the 50 sample listener locations for each of the four test cases. Corresponding indoor levels are then obtained by subtracting typical values for commercial or residential building sound attenuation. For test cases 1 and 2 (summer), residential windows were assumed to be partly open; for test cases 3 and 4 (winter) residential windows were assumed to be closed (with storm windows). For the frequency region within the 500 Hz octave band, the sound attenuation into buildings is estimated to be 16 dB for test cases 1 and 2, and 31 dB for test cases 3 and 4 [4]. For commercial buildings, the outdoor-to-indoor noise reduction is estimated to be 31 dB, assuming closed and sealed windows for all four scenarios.

5.3 Assumptions about Chance of Alert

The outdoor and indoor siren levels calculated by the above procedure provide some of the information required for the analysis of the chance of alert. In addition, it is necessary to know the level of interfering background noise at the listener locations.

Figure 5-1 is a flow chart of the analysis computations. The analysis is divided into components (rows) that correspond to the possible activities of people for the various scenarios. The major components relate to people (1) at home (outside or inside), (2) at work, or (3) in motor vehicles. The chance of alert is estimated for each activity component and is then multiplied by the fraction of people likely to be engaged in that activity (activity fraction). The results are summed to obtain the overall chance of alert for each listener location and for each test case. Overall chances of alert for the various scenario (test case) conditions are then obtained by averaging the chances for all rural and/or urban sample listener sites. Note that all estimates assume siren signal duration of 4 minutes: an average of the "3 to 5 minutes" called for in Appendix 3 of NUREG-0654. The effects of different siren signal durations are discussed in Appendix E.

Siren detectability is a function of the siren signal level and of the background noise level in a "critical frequency band" centered at the signal frequency. For this analysis, outdoor and indoor detectability is estimated based on the signal-to-noise (S/N) difference in the 630-Hz 1/3-octave frequency band. The chosen criterion for alerting is that the given signal level must be 9 dB or more above the minimum background noise level at any

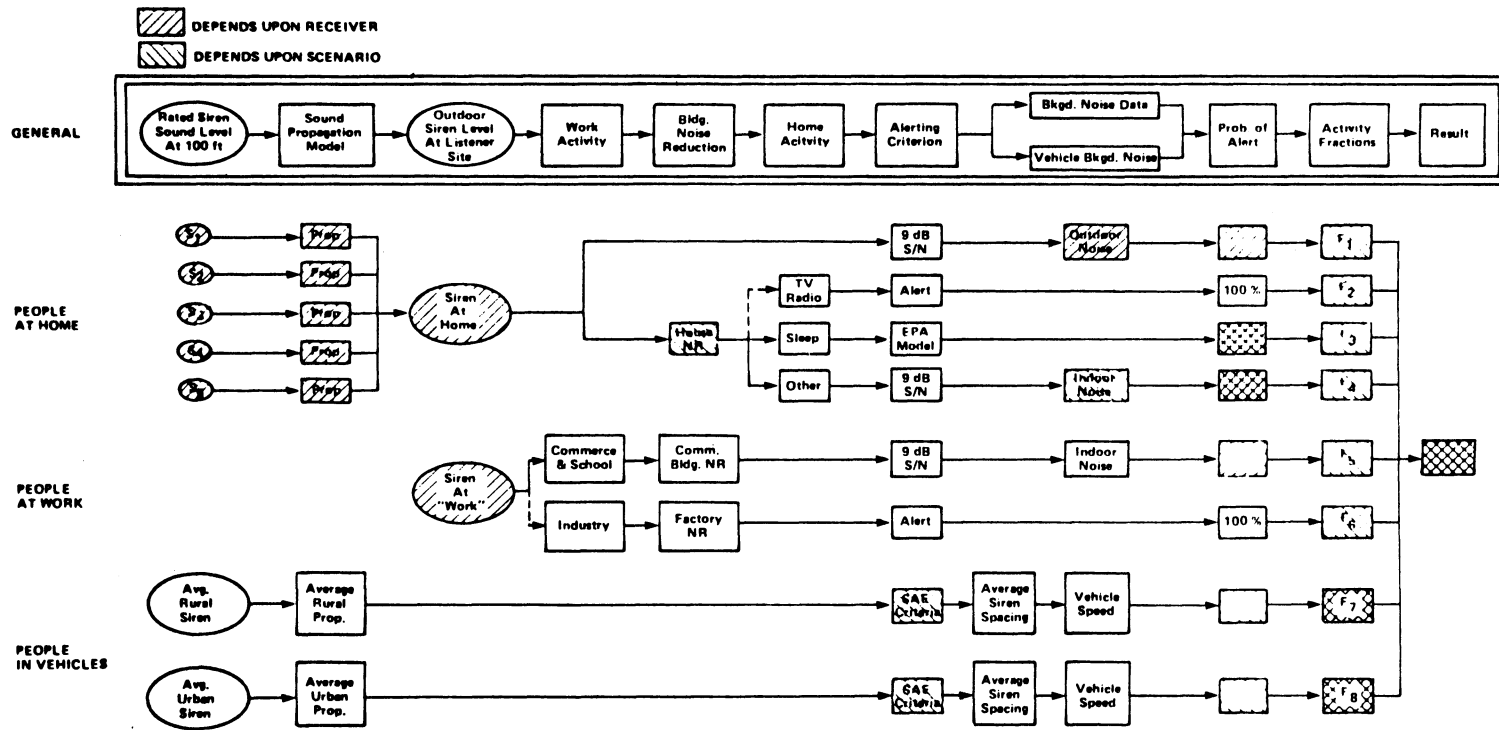

FIG. 5-1. FLOW OF COMPUTATIONS.

time during a 4-minute period for people who are not sleeping (i.e., a S/N difference of 9 dB). The chance of alert while sleeping is based on the indoor siren Single Event Level (SEL) - a measure of total acoustic energy - and the sleep-awakening model developed by the U.S. Environmental Protection Agency [5]. The graph used for estimating the chance of alert during sleep is shown in Fig. 5-2; for the Zion analysis, the curve for the chance of awakening one out of two sleepers was used.

5.4 Alerting People Out of Doors

For the analysis of the ability of sirens to alert people out of doors, background noise levels are based on noise measurements conducted by BBN in the vicinity of the Trojan Nuclear Plant in Oregon, near the Zion Nuclear Power Station in New York, and upon the body of data in BBN files. The data typically consisted of statistical summaries of background noise at various types of locations. The summaries provide the L_{90} (sound level exceeded 90% of the time) for 1-minute samples of data in the 1/3-octave frequency band centered at 630 Hz.* These data were used to estimate the range of background noise levels that are likely to exist during any 4-minute period (1 minute for rotating sirens) for a variety of outdoor environments. The results are summarized in Table 5.4, which specifies the background noise environment for urban and rural areas. Only daytime noise levels are presented since the nighttime scenarios assume that essentially no people are outdoors at night.

The siren sound level necessary to alert is 9 dB greater than the minimum background noise level that could exist in any

*The L_{90} was used as a conservative estimate of the minimum sound level.

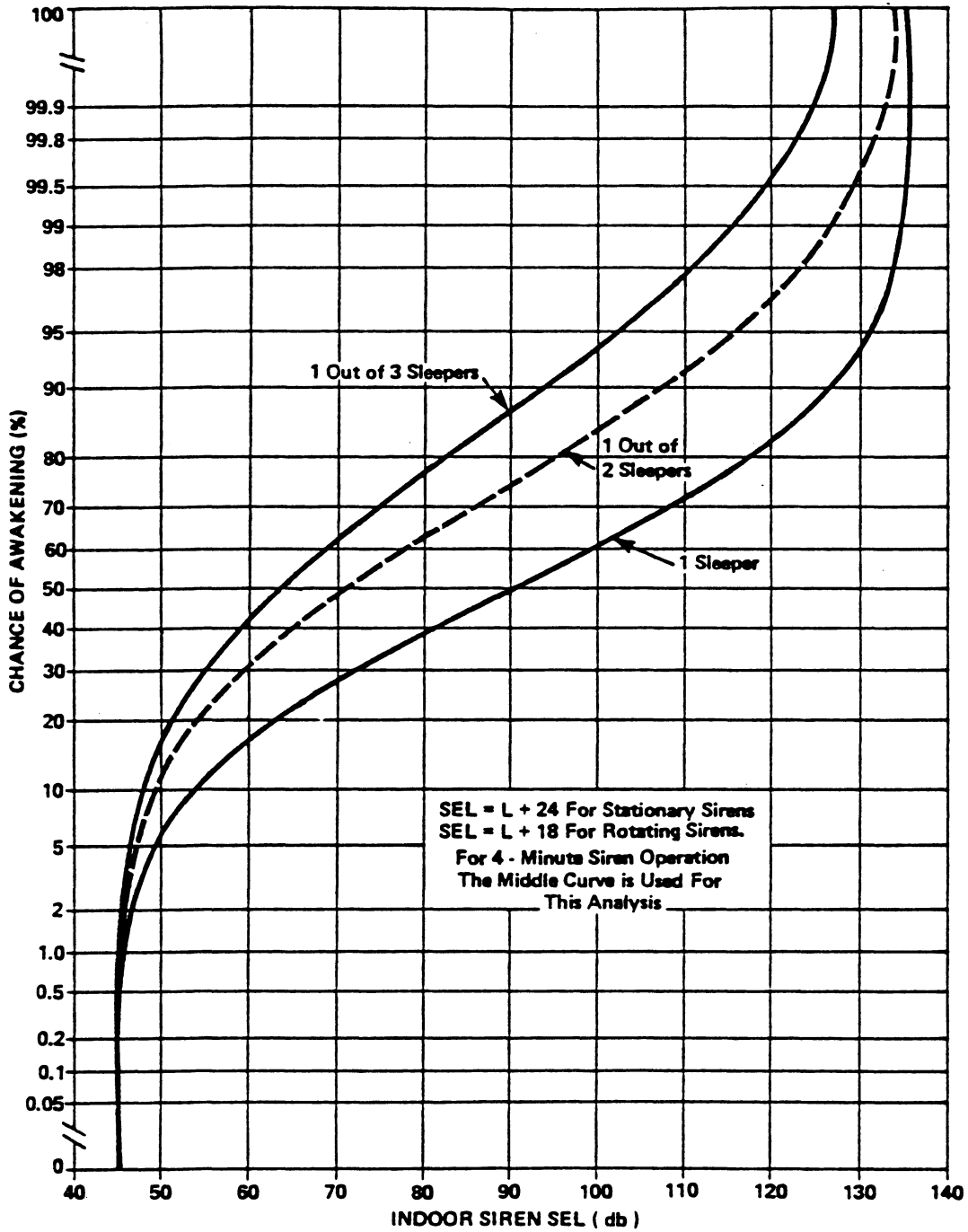

FIG. 5-2. CHANCE OF ALERT FOR AWAKENING PEOPLE ASLEEP.

TABLE 5.4. MINIMUM BACKGROUND NOISE LEVELS FOR GENERALIZED CATEGORIES OF OUTDOOR ENVIRONMENTS (SEE FIGS. 5-3 AND 5-4 FOR DISTRIBUTIONS).

Generalized Background Noise Environment	Range of Minimum Background Noise Levels ¹ (dB)	
	1-Minute Period ²	4-Minute Period ³
I. URBAN-DAY ⁴ (Includes Rural locations within 1000 ft. of major roadways)	21-57	21-57
II. RURAL-DAY ⁵ (Except Rural locations within 1000 ft. of major roadways)	17-48	17-47

NOTES:

1. Refers to the range of the minimum (L_{90}) sound pressure levels in the 630 Hz one-third octave band during the specified time period.
2. Applicable for analysis of rotating sirens operated for 4 minutes.
3. Applicable for analysis of stationary sirens operated for 4 minutes.
4. Urban locations are defined as the pink "building exclusion" areas of topographic maps, or as those communities with a population density exceeding 2000 people per square mile. Major roadways are defined as roadways with more than one lane in each direction.
5. Rural locations are taken to be all sites not classified as urban (above).

4-minute period (1 minute for rotating sirens), adjusted for the probability distribution of such minima. The chance of alert for people outdoors was determined for each scenario at each listener site using Figs. 5-3 and 5-4.

Outdoor background noise in urban areas and along rural roadways is caused predominantly by motor vehicle traffic. It is generally insensitive to seasons of the year, but varies markedly with time of day. Minor traffic variations (i.e., less than a factor of 2 in traffic volume) have little effect on the background noise.

In rural areas remote from roadways, outdoor background noise can be seasonal (birds, insects, etc.) and can vary with the weather (wind, rain, waterflow, surf). However, few people live or work in such "natural" acoustic environments.

Note that results are given separately for stationary sirens and rotating sirens. This is because rotating sirens would actually produce their estimated sound level during about one quarter of the presumed 4-minute operating time at any particular listener location. Thus, the results for rotating sirens are based on 1-minute statistics rather than on 4-minute statistics.

In summary, information regarding siren type, estimated siren sound level, background noise category at the listener site, and test-case conditions were used in conjunction with Figs. 5-3 and 5-4 to estimate the chance of siren detection outdoors at the Zion Site.

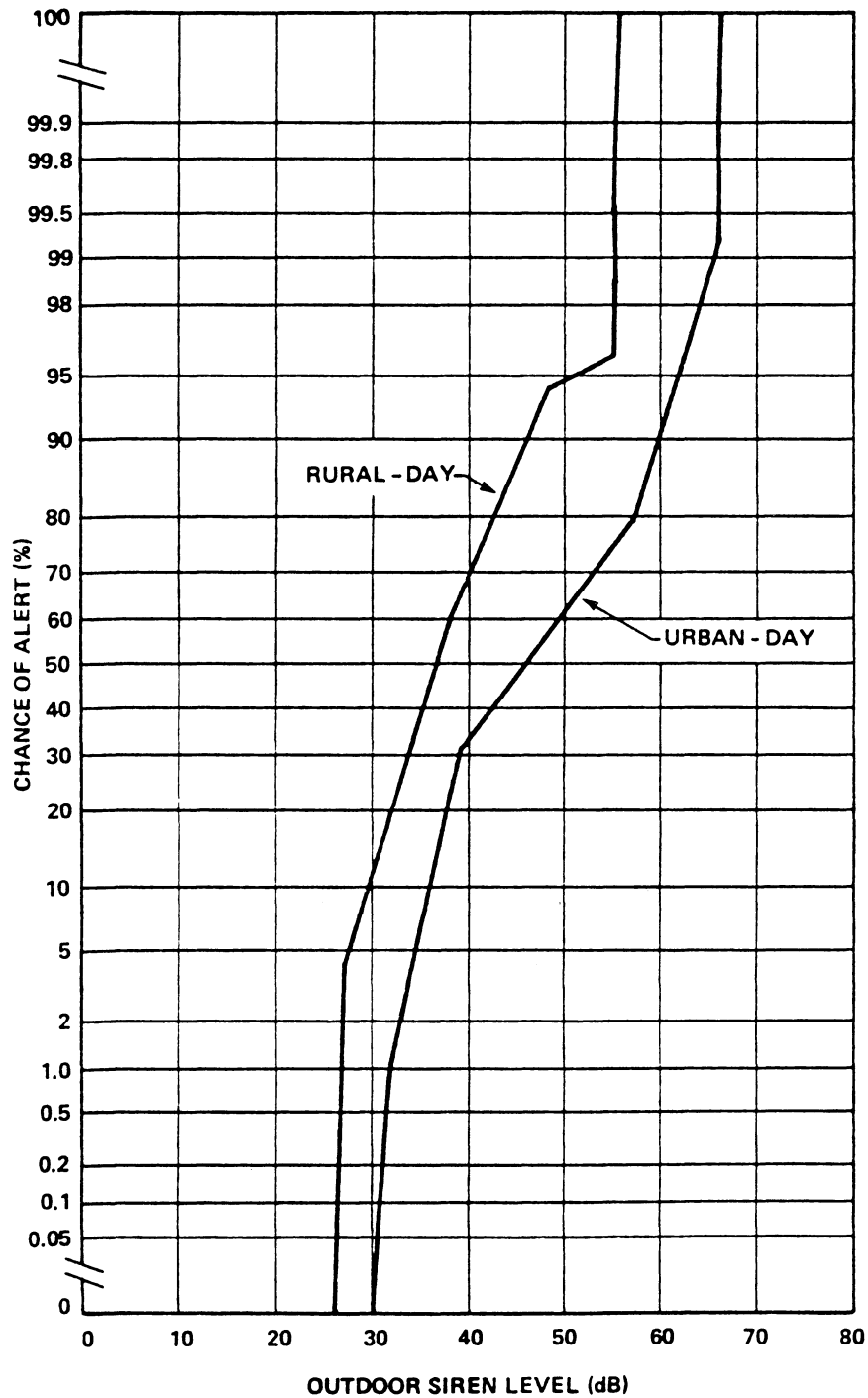

FIG. 5-3. CHANCE OF ALERT FOR PEOPLE OUTDOORS (4-MINUTE STATIONARY SIREN).

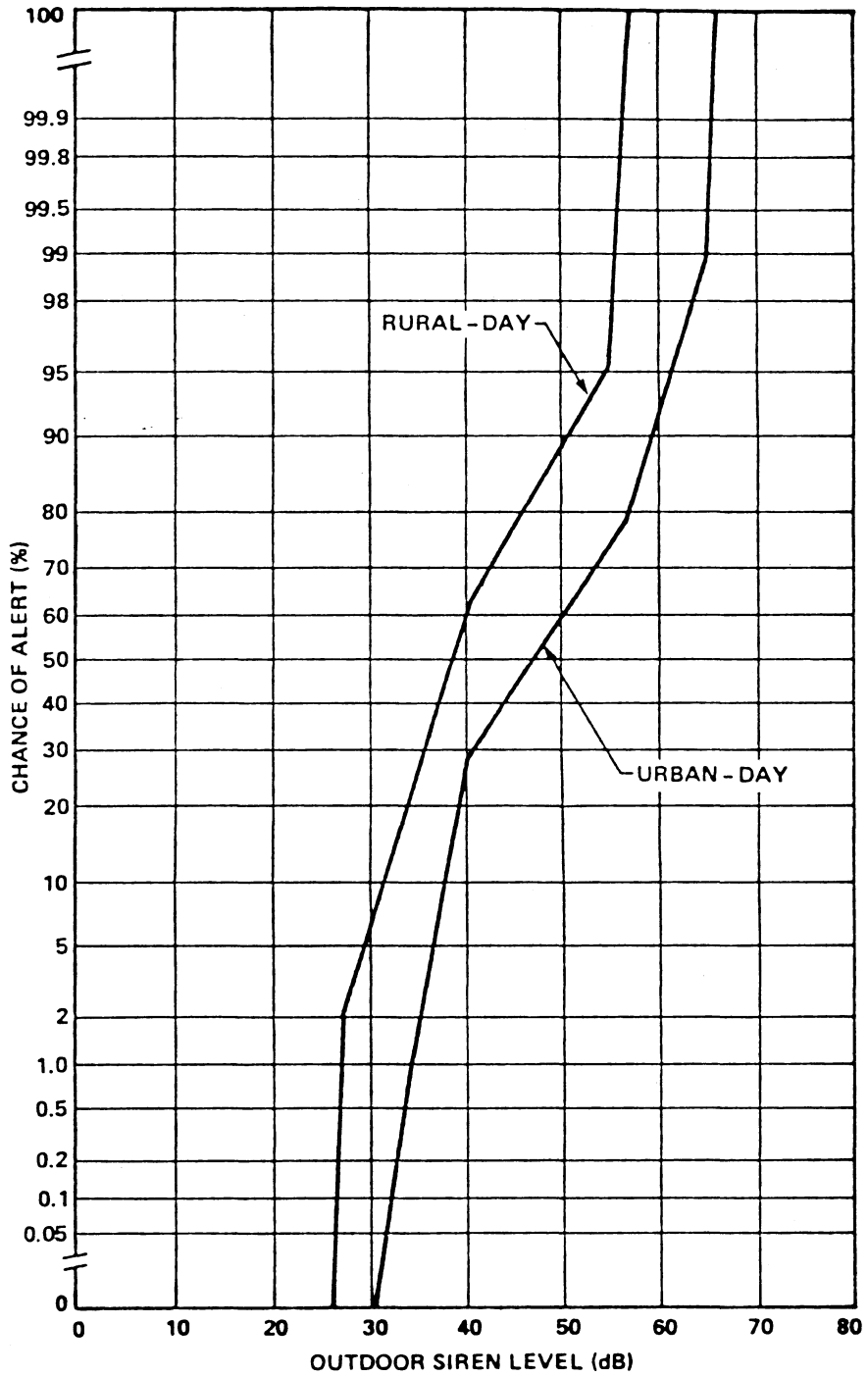

FIG. 5-4. CHANCE OF ALERT FOR PEOPLE OUTDOORS (4-MINUTE ROTATING SIREN).

5.5 Alerting People Indoors

For the analysis of alerting people indoors at home, three types of activities are considered. These are (1) listening to radio or TV, (2) sleeping, or (3) other activities that range from quiet to noisy situations. Table 5.5 provides the percentages assumed for various activities for each scenario.

For people listening to radio or TV, the chance of alert is 100%. For people sleeping, the chance of alert is calculated from the indoor siren SEL using the relationship shown in Fig. 5-2 for the chance of awakening one out of two sleepers. For all other indoor activities, the chance of alert is based on generalized categories of actual indoor background noise measurements under a wide variety of conditions. The ranges of minimum background noise levels for these categories are listed in Table 5.6.

Results for test cases 1 and 3 are provided in Fig. 5-5 for 4-minute stationary sirens and in Fig. 5-6 for 4-minute rotating sirens. Thus, given the siren type, indoor siren level and test case condition, these figures were used to estimate the chance of alerting for indoor activities other than sleeping or listening to radio or TV.

For the analysis of alerting at work, two activity categories are considered: (1) commercial/institutional, and (2) industrial environments. For the Zion analysis, it was assumed that 75% of the working population are in commercial establishments while the remaining 25% are in industrial locations. For commercial locations, the chance of alert is based on the statistics of background noise measured in a typical office environment, using Figure 5-7. For industrial locations, it has been assumed that 100% of the people are likely to be alerted by some means of communication other than sirens.

TABLE 5.5. ASSUMED ACTIVITIES AND BACKGROUND NOISE ENVIRONMENTS FOR PEOPLE INDOORS.

Scenario	Percentages of People Engaged in Various Activities Indoors (%)						
	At Place of Business	Listening to TV/Radio	Sleeping	Indoor Noise Environment			
				Obviously Noisy ¹	Busy and Active ²	Isolated ³	Obviously Quiet ⁴
1. Warm Summer Weekday Afternoon (clear to partly cloudy)	41	27	5	--	8	5	14
2. Summer Weekday Night (clear to partly cloudy)	4	--	96	--	--	--	--
3. Winter Weekday During Evening Commuting Hours (cold and overcast)	--	20	--	5	50	20	5
4. Winter Night During Snowfall	5	--	95	--	--	--	--

NOTES:

1. Vacuum cleaning, dishwasher, shower, vent fan on, etc.
2. Dinner conversation, kitchen work, playing music, children at play, etc.
3. Noise-producing activity in adjacent room, soft background music, etc.
4. Reading, study, eating alone.

TABLE 5.6. MINIMUM BACKGROUND NOISE LEVELS FOR GENERALIZED CATEGORIES OF INDOOR ACTIVITIES/ENVIRONMENTS.

Generalized Activity/Environment	Range of Minimum Background Noise Levels in dB ¹	
	1-Min. Period ²	4-Min. Period ³
At home, obviously noisy ⁴ (i.e., vacuum cleaning, dishwasher, shower, vent fan on)	41-76	41-73
At home, busy and active ⁴ (i.e., dinner conversation, kitchen work, playing music, children at play)	21-64	21-54
At home, isolated ⁴ (i.e., noise-producing activity in adjacent room, soft background music)	23-49	23-38
At home, obviously quiet ⁴ (i.e., reading, study, eating alone)	11-39	11-28
At work, office and commercial	28-49	28-45

NOTES:

1. Refers to the range of the minimum (L_{90}) sound pressure levels in the 630 Hz one-third octave-band.
2. Applicable for analysis of rotating sirens operated for 4-minutes.
3. Applicable for analysis of stationary sirens operated for 4-minutes.
4. To simplify the procedure, these are combined into a single indoor range on the basis of the activity fractions in Table 5.5.

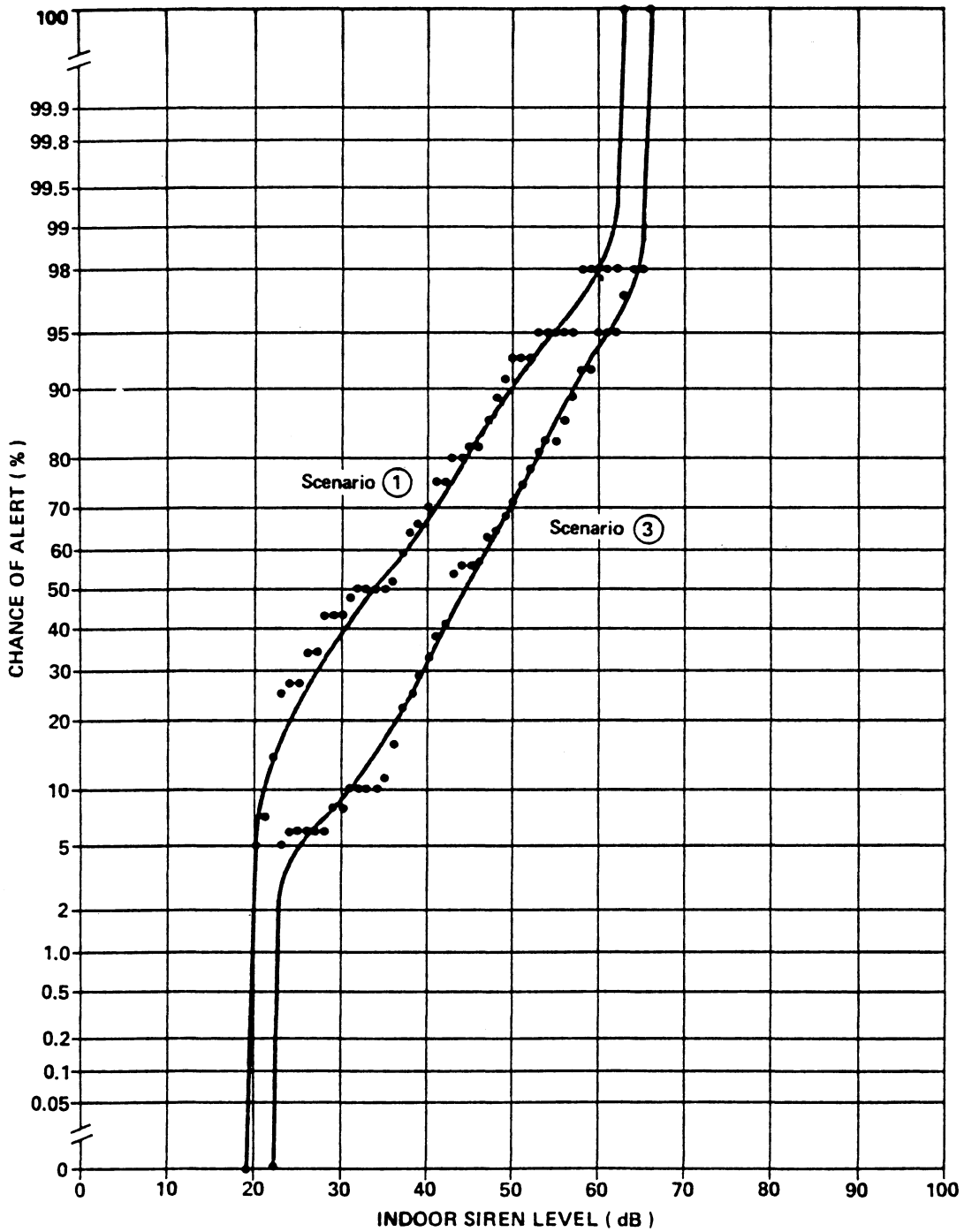

FIG. 5-5. CHANCE OF ALERT FOR PEOPLE INDOORS AT HOME (4-MINUTE STATIONARY SIREN).

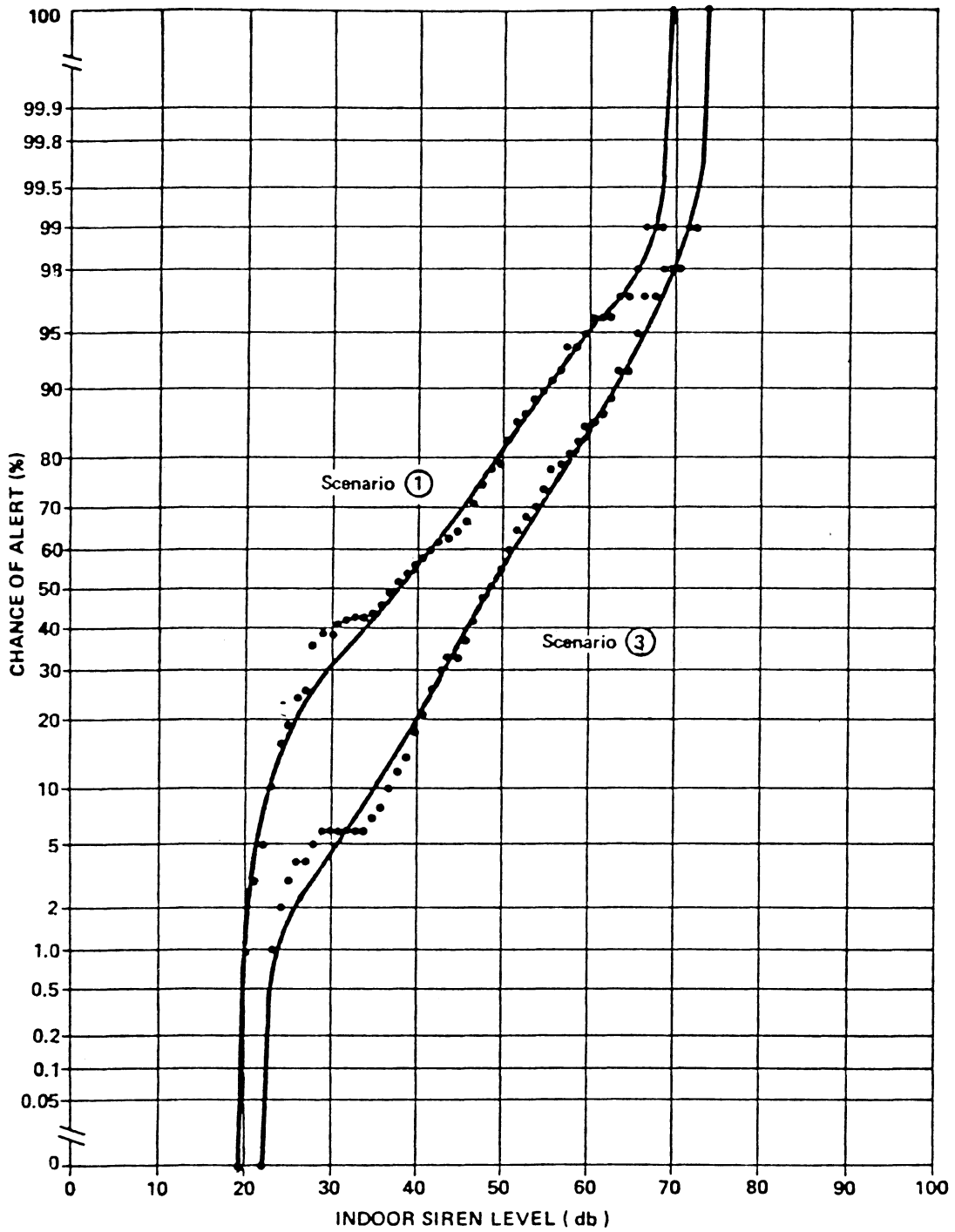

FIG. 5-6. CHANCE OF ALERT FOR PEOPLE INDOORS AT HOME (4-MINUTE ROTATING SIREN).

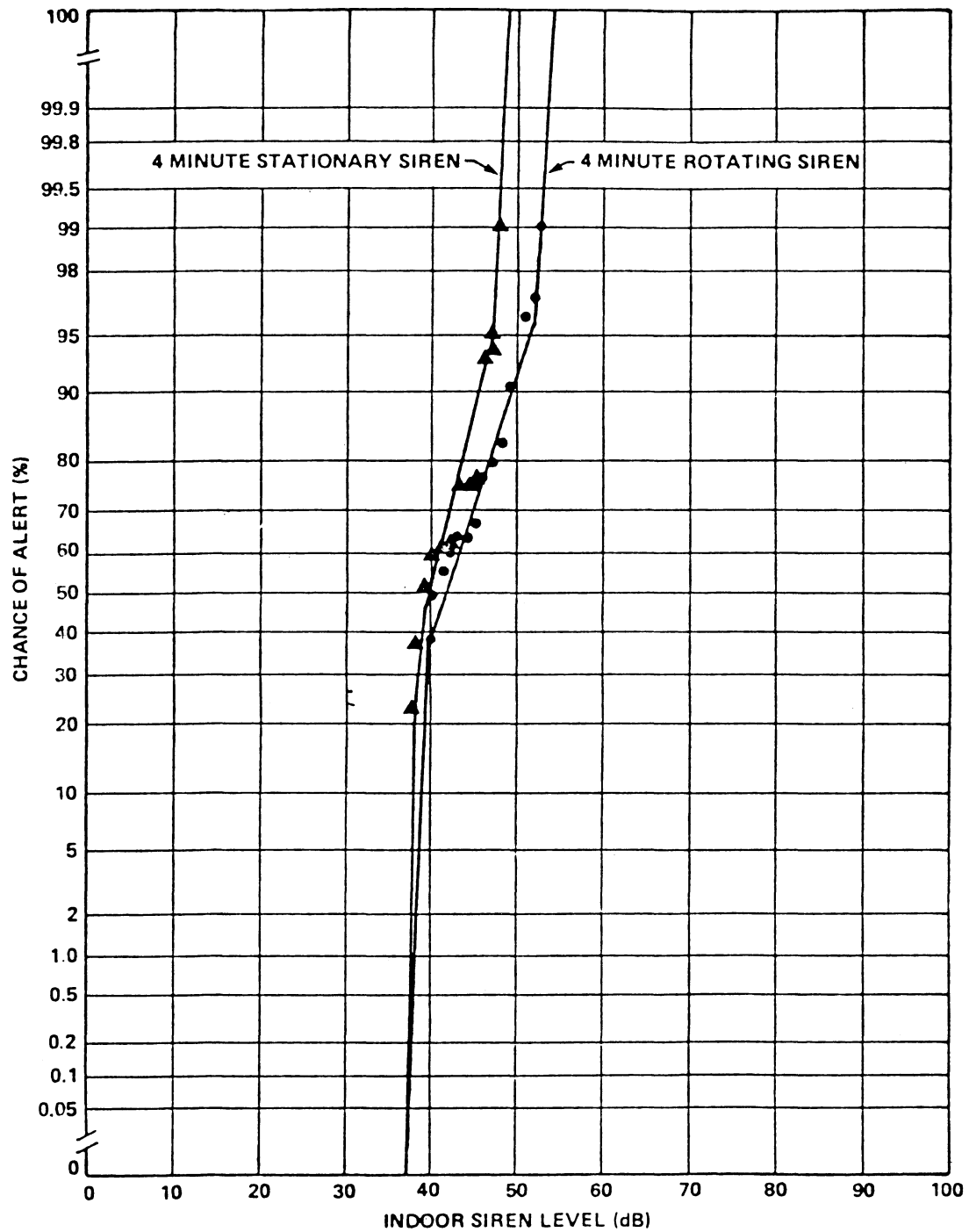

FIG. 5.7 CHANCE OF ALERT FOR PEOPLE INDOORS AT WORK IN COMMERCIAL/INSTITUTIONAL ESTABLISHMENTS.

5.6 Alerting People in Motor Vehicles

The analysis for the alerting of motorists is based on the assumption of an average siren signal strength and spacing throughout the EPZ. The chance that a motorist will pass within the alert range of a siren during its 4-minute operation is estimated as follows:

$$C = \frac{2R+d}{L} \times 100 \text{ (not to exceed 100\%)}$$

where C is the chance of alert (%), R is the maximum alert distance (ft), d is distance traveled in 4 minutes (ft), and L is the average siren spacing (ft). Separate analyses were carried out for urban and rural areas of the Zion EPZ.

The average urban siren produces a sound level of 123 dB at 100 ft and the average rural siren produces a sound level of 124 dB at 100 ft. Alerting ability was evaluating by using the results of a study for the Society of Automotive Engineers (SAE) [6]. Siren alerting levels for speeds of 55 mph and 30 mph with windows shut or open were first determined from the SAE study results. The average siren source levels for rural and urban areas were then reduced to alerting levels in accordance with the propagation models from current NRC guidelines (i.e., 10 dB/double distance) [7]. In this manner, the maximum alert distance (R) was calculated for each driving condition. The distance traveled in 4 minutes (d) was calculated based on speed for each case, and the average siren spacing (L) was estimated to be 5,045 ft for urban areas and 19,240 ft for rural areas.

The calculations of alerting ability for motorists are summarized in Table 5.7. The results indicate that the chance of alert is expected to be 100% for all conditions applicable to the Zion analysis.

TABLE 5.7. SIREN ALERTING FOR MOTORISTS.

Area	Vehicle Speed (mph)	Vehicle Window Condition	Reqd. Signal for Alert (dB)	Max. Alert Dist. R (ft)	4-min Travel Dist., d (ft)	Avg. Siren Spacing L (ft)	Chance of Alert (%)
URBAN	30	Closed	89	1,000	10,560	5,045	100
		Open	86	1,200	10,560	5,045	100
RURAL	55	Closed	96	700	19,360	19,240	100
		Open	90	1,000	19,360	19,240	100

REFERENCES

1. Keast, D.N., Towers, D.A., and Anderson, G.S., "Procedure for Analyzing the Effectiveness of Siren Systems for Alerting the Public," BBN Report No. 4774 (February, 1982), (Published by the U.S. Nuclear Regulatory Commission as NUREG/CR-2654.)
2. L.L. Beranek, ed., "Noise and Vibration Control," McGraw-Hill Book Company (1971).
3. C.M. Harris, ed., "Handbook of Noise Control," Chapter 3, McGraw-Hill Book Company (1979).
4. D.A. Driscoll, J.P. Dulin, Jr., and D.N. Keast, "Attenuation of Northern Dwellings to a Linear Source of Noise." Presented at the 95th Meeting of the Acoustical Society of America, Providence, R.I. (May 1978).
5. U.S. Environmental Protection Agency, "National Roadway Noise Exposure Model," Draft Report (1980).
6. R.C. Potter et al., "Effectiveness of Audible Warning Devices on Emergency Vehicles," U.S. Department of Transportation, Report DOT-TSC-OST-77-38, Washington, DC (August 1977).
7. "Criteria for Preparation and Evaluation of Radiological Emergency Response Plans and Preparedness in Support of Nuclear Power Plants," Nuclear Regulatory Commission, NUREG-0654, Revision 1, Appendix 3, Part C.3.e, Washington, DC (November 1980). (The Federal Emergency Management Agency also publishes this document as FEMA-REP-1.)



APPENDIX A: POPULATED-WEIGHTED RANDOM SELECTION OF LISTENING POINTS AT THE TROJAN SITE

The objective of the listener-site-selection process is to identify 50 randomly selected residential locations within the 10-mile EPZ surrounding the Trojan Nuclear Plant. It was arbitrarily decided that 40 sites were to be in rural areas (population density below 2000 persons/sq mi) and 10 sites were to be in urban areas (population density above 2000 persons/sq mi). Of the rural sites, 20 were to lie within 5 miles of the plant and 20 were to lie between 5 to 10 miles from the plant. These ground rules were established based on site-specific information.

The various steps used in the site selection procedure are described below:

1. The boundaries of urban and rural areas were defined on a set of USGS topographical maps covering the EPZ. Those regions denoted by USGS as "building omission areas" on the maps (pink shading) were assumed to be urban (with uniform population density), and all other areas were assumed rural. The urban areas included only the communities of Longview and Kelso.
2. A population distribution drawing (see Fig. A-1) consisting of a 10-mile-radius circle divided into annular sectors defined by interior circles and radii was superimposed on the U.S.G.S. maps. Population distribution information consisted of the number of people within each annular sector. These data were used to population-weight the random selection process for rural sites as described in Step 3 below.

TROJAN NUCLEAR PLANT

POPULATION IN ANNULAR RINGS	
0 - 1	176
1 - 2	417
2 - 3	1922
3 - 4	2398
4 - 5	3406
5 - 10	56307

POPULATION WITHIN RADIAL DISTANCE of SITE	
1	176
2	593
3	2515
4	4913
5	8319
10	64626

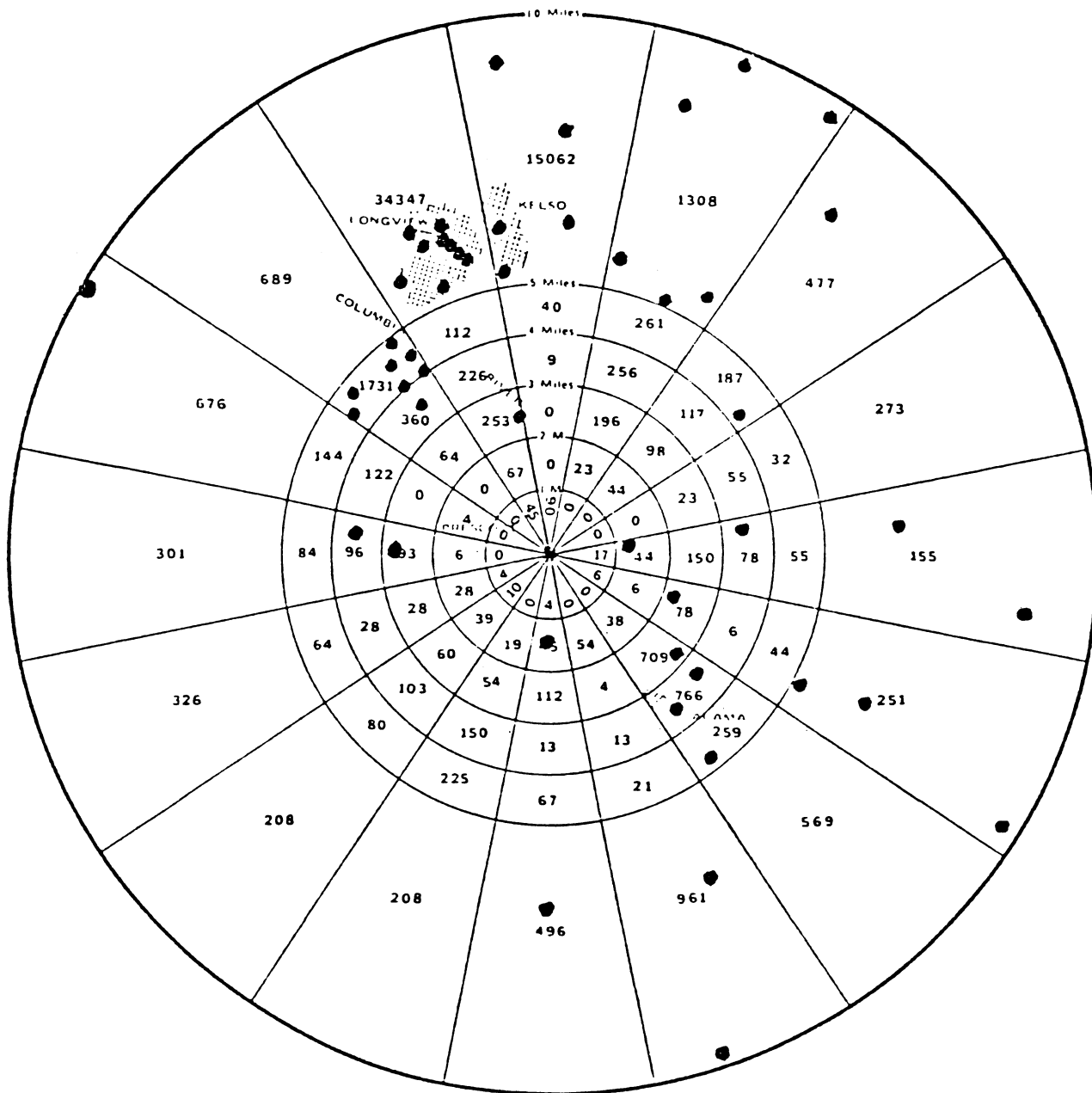
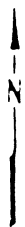

FIG. A-1. 1980 PROJECTED POPULATION DISTRIBUTION WITHIN 10 MILES AND RANDOMLY SELECTED LISTENER SITES (APPROXIMATE).

3. Each annular sector was first assigned a number. A range of numbers was then assigned to each sector according to the population in that sector. For example, Sector no. 1, due north of the site, had a population of 90 and thus was assigned numbers 1 through 90. Sectors 2 through 4 (moving clockwise) had zero population and were therefore not assigned any numbers. Sector 5 had a population of 17 and was assigned numbers 91 through 107. This process was continued until each number between 1 and 18,600 (the total estimated rural population) was assigned to a particular sector. A random number generator (available, for example, on a Texas Instruments Model TI-59 hand calculator) was then used to select 20 numbers at random between 1 and 8,293 (representing sectors within 5 miles of the plant) and 20 numbers at random between 8,294 and 18,600 (representing sectors between 5 and 10 miles from the plant). Each number selected represented one site (to be chosen later) within the sector assigned to that number. Thus, sectors with larger populations would have a greater probability of including chosen listener sites.
4. Having determined the sector location for each rural listener site, the next step in the procedure involved selecting the actual location of each site within its respective sector. This was accomplished by first overlaying a rectangular coordinate grid on each sector of interest on the USGS map. The grid was composed of boxes with dimensions of

approximately 1000 ft sq, and each box was assigned an X and a Y coordinate according to its location on the grid. The grid was positioned so that the X axis was oriented in the east-west direction and the Y axis was oriented in the north-south direction, and so that all parts of the sector of interest were covered by a positive (X,Y) coordinate pair box. A random number generator was then used to select random pairs of numbers within the X and Y ranges including the sector of interest. Each X,Y pair was used to locate a particular 1000 ft sq box on the USGS map. If no residences were inside the square area or if the area fell outside of the sector of interest, the coordinate pair was disregarded and another pair was chosen at random. This process was continued until a square area including one or more residential structures was found in the sector of interest. The listener site was then chosen to be any residence within the randomly selected square area. In this manner, the sample of 40 rural listener sites was selected.

5. The selection procedure for urban sites was similar to that for rural sites, except that each distinct urban area was treated as a sector and population was assumed to be uniformly distributed throughout each urban sector. Thus, random number pairs were used to select square areas on the grid, and a listener site was chosen anywhere in that area provided that the site fell within the urban sector of interest. In this manner, the sample of 10 urban listener sites was selected.

The above procedure resulted in a random sample of 50 listener locations, distributed throughout the EPZ as shown roughly on Fig. A-1.



APPENDIX B: TEST CASES (SAMPLE SCENARIOS) FOR THE TROJAN SITE

1. Warm summer weekend day, weather clear to partly cloudy

People: 70% out of doors
20% indoors
10% in motor vehicles (windows open)

Buildings: Windows open

Wind: 10 mph - from the north throughout the region

upslope in the canyon

Temperature Gradient: $-2^{\circ}\text{C}/100\text{ m}$; Class A
Relative Humidity: 50%

2. Summer weekday night, weather clear to partly cloudy

People: 95% indoors, sleeping
4% indoors, at work
1% in motor vehicles (windows closed)

Buildings: Windows open

Wind: from the north on ridges and plateaus east and west of the site

5 mph - from the south in the river valley

downslope in the canyons

Temperature Gradient: $+1.5^{\circ}\text{C}/100\text{ m}$; Class E
Relative Humidity: 90%

3. Winter weekday during evening commuting hours
Cool, damp, and overcast

People: 70% indoors
25% in motor vehicles (windows closed)
5% out of doors

Buildings: Windows closed

Wind: 3 mph - from the south

calm in the canyons

Temperature Gradient: +1°C/100 m; Class E

Relative Humidity: 80%

4. Winter night during rainstorm

People: 95% indoors, sleeping

4% indoors, at work

1% in motor vehicles (windows closed)

Buildings: Windows closed

Wind: 15 mph - from the south

5 mph - downslope in the canyons

Temperature Gradient: +1°C/100 m; Class E

Relative Humidity: 90%

Sources: EIR, Amendment 1, March 1973, Fig. 2.3.4, Tables 2.3.3 and 2.3.13. Site-specific wind velocity profile inversion at Trojan has not been considered.

APPENDIX C: SIREN LOCATIONS FOR THE TROJAN EPZ

This appendix provides siren locations for the Trojan EPZ on a set of maps (1-6). A siren location map index is provided which shows the relationship of individual maps to the Trojan EPZ. Table C.1 provides information on the type and rating for each siren, as well as a guide for locating the sirens on the maps.



TROJAN EMERGENCY WARNING SYSTEM
SIREN LOCATION MAP INDEX

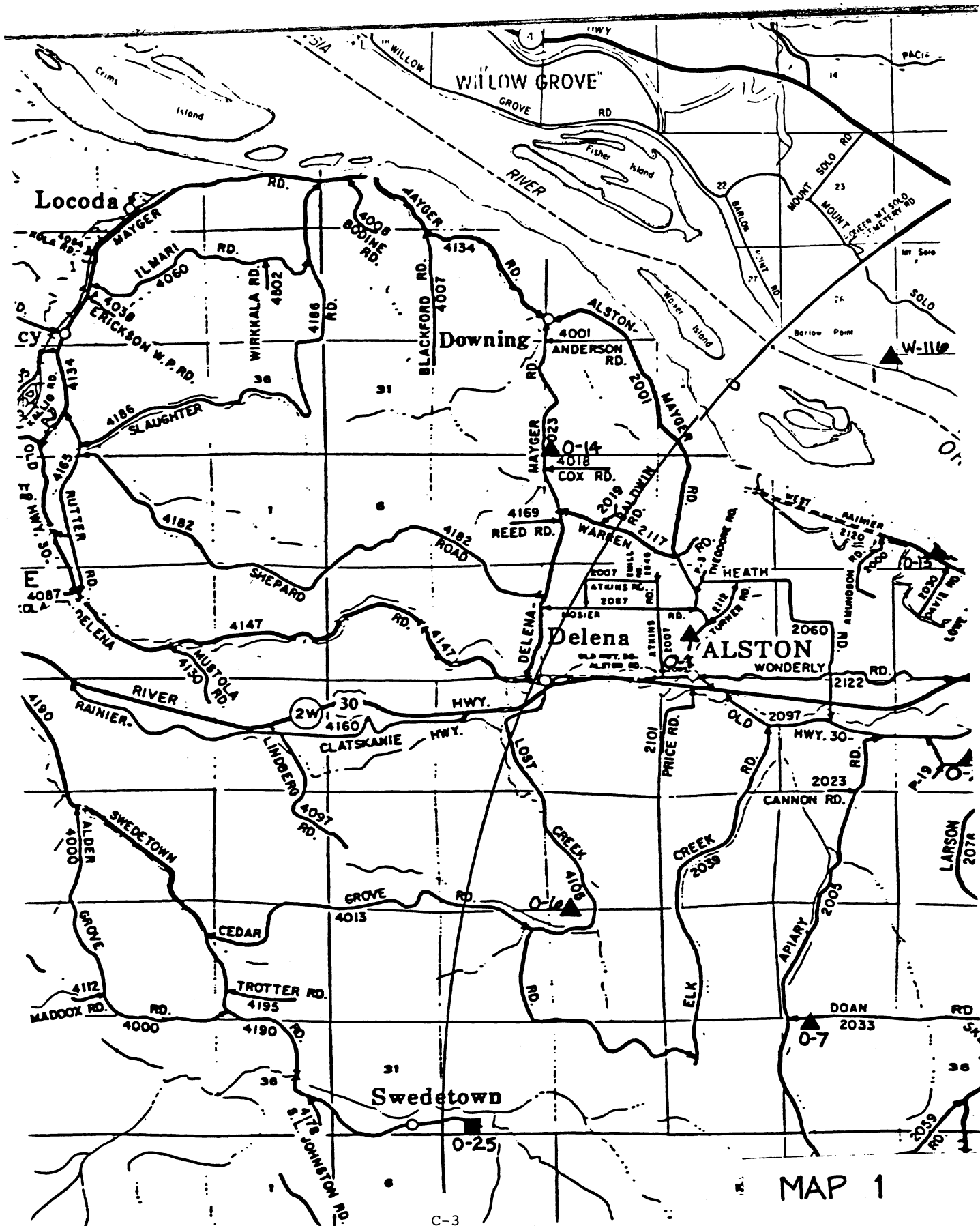

MAP 1

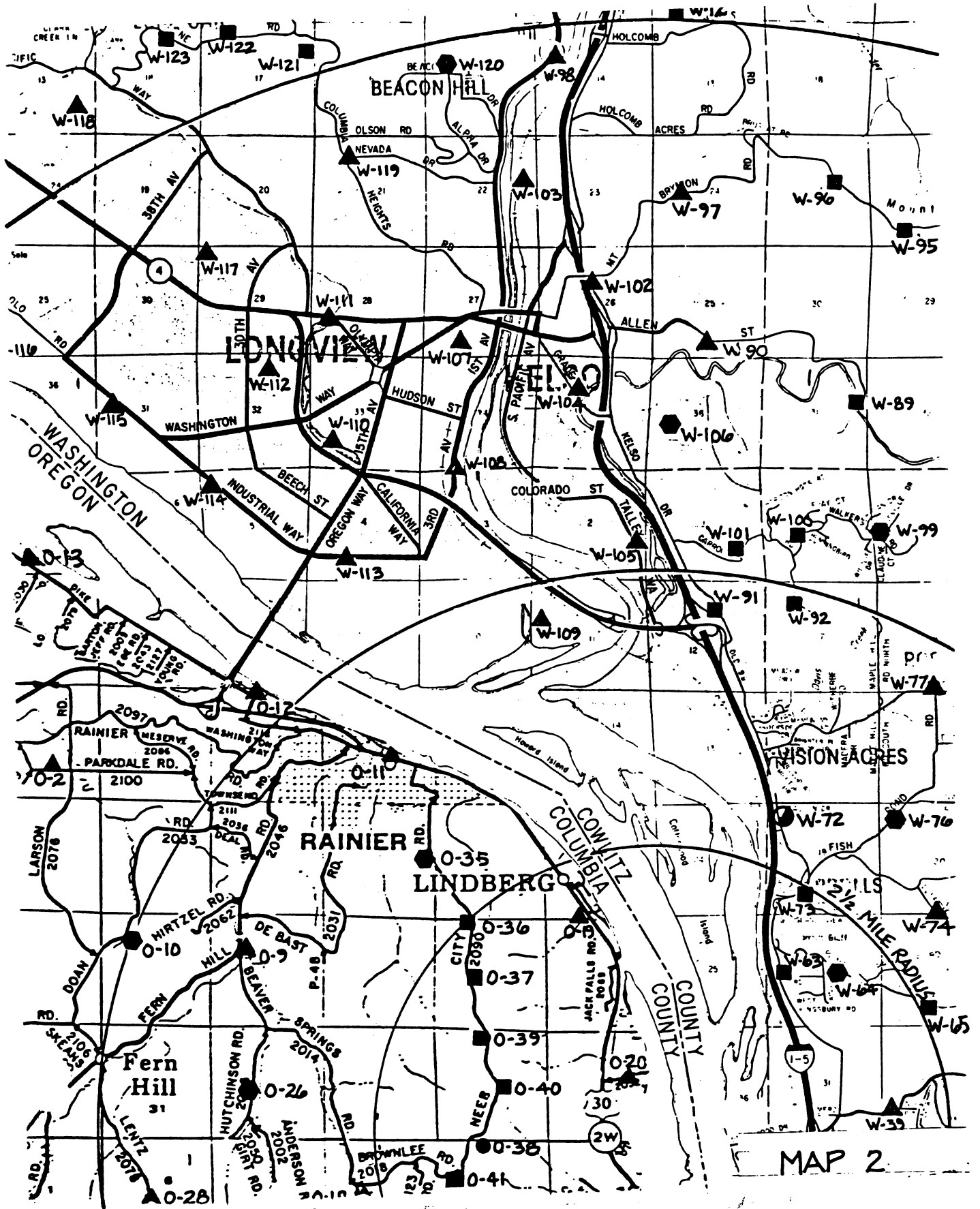

MAP 2

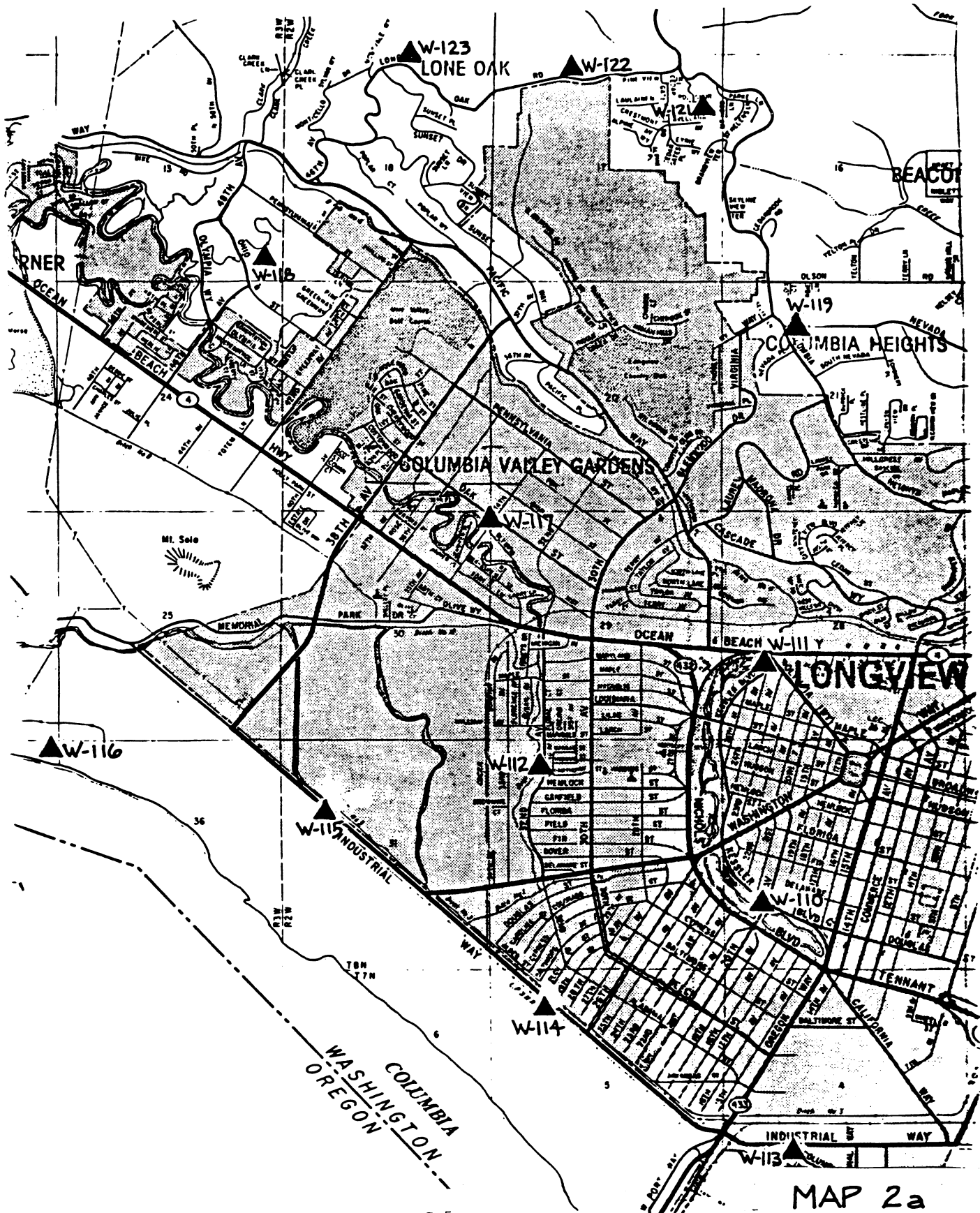

MAP 2a

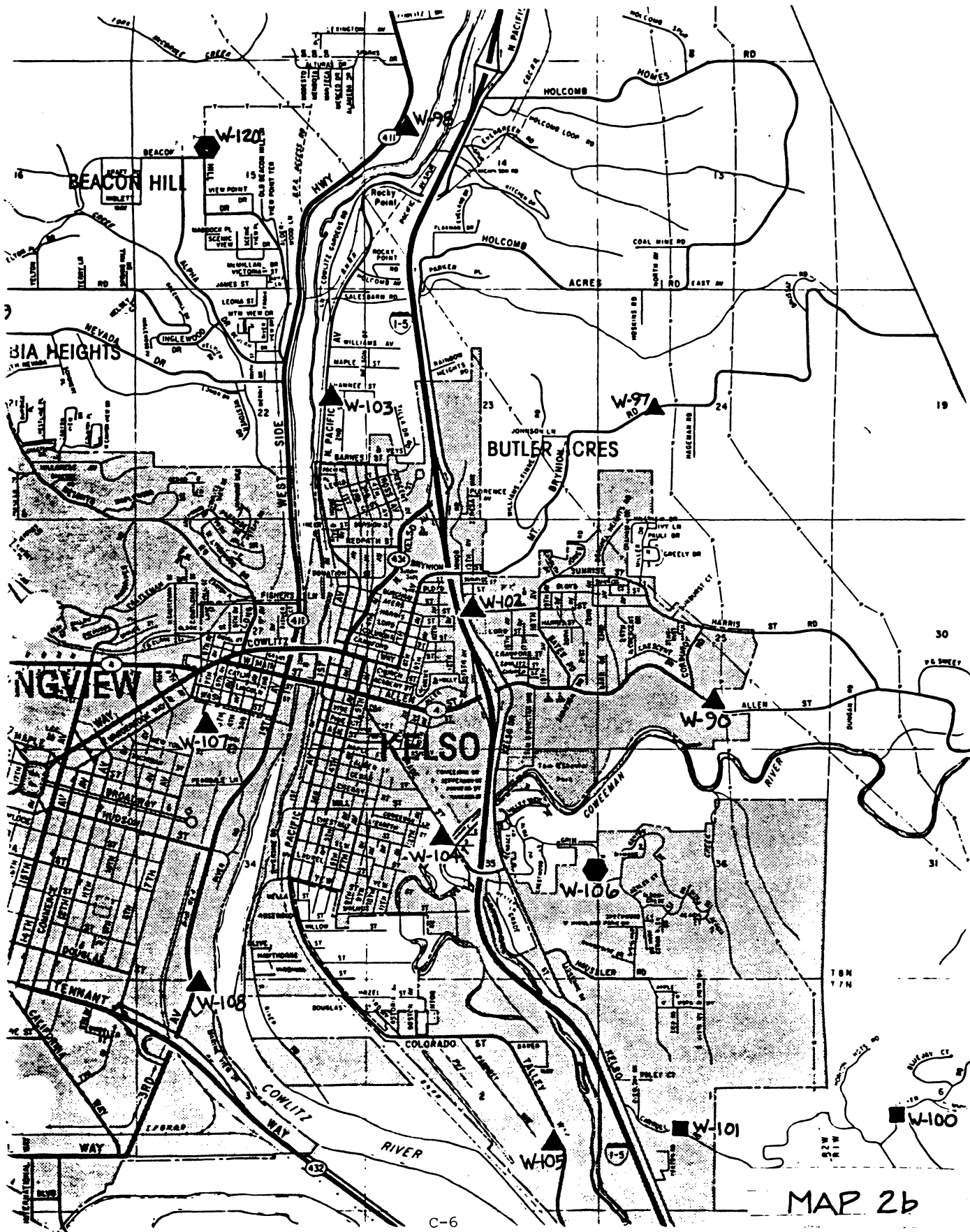

MAP 2b

C-6

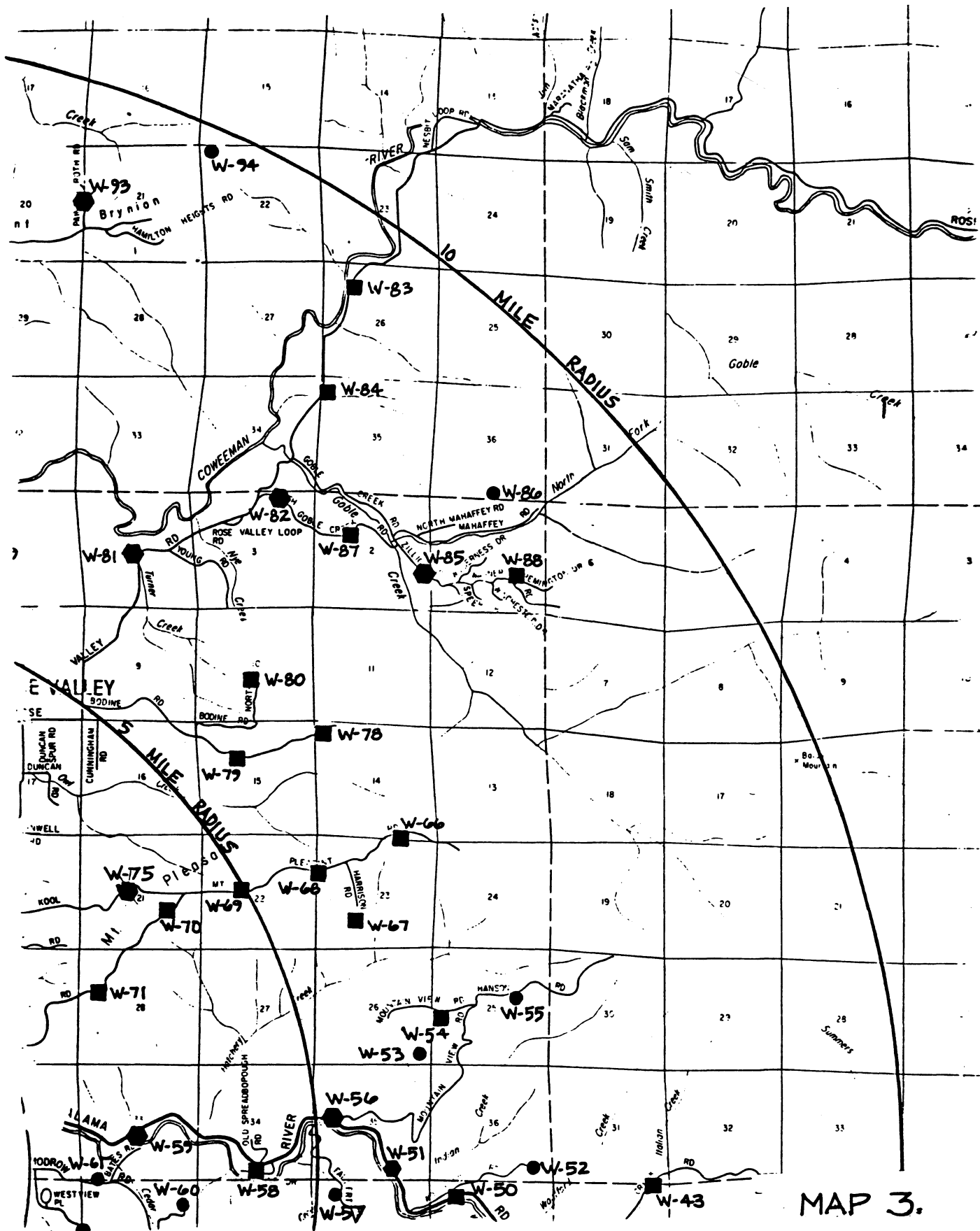

MAP 3.

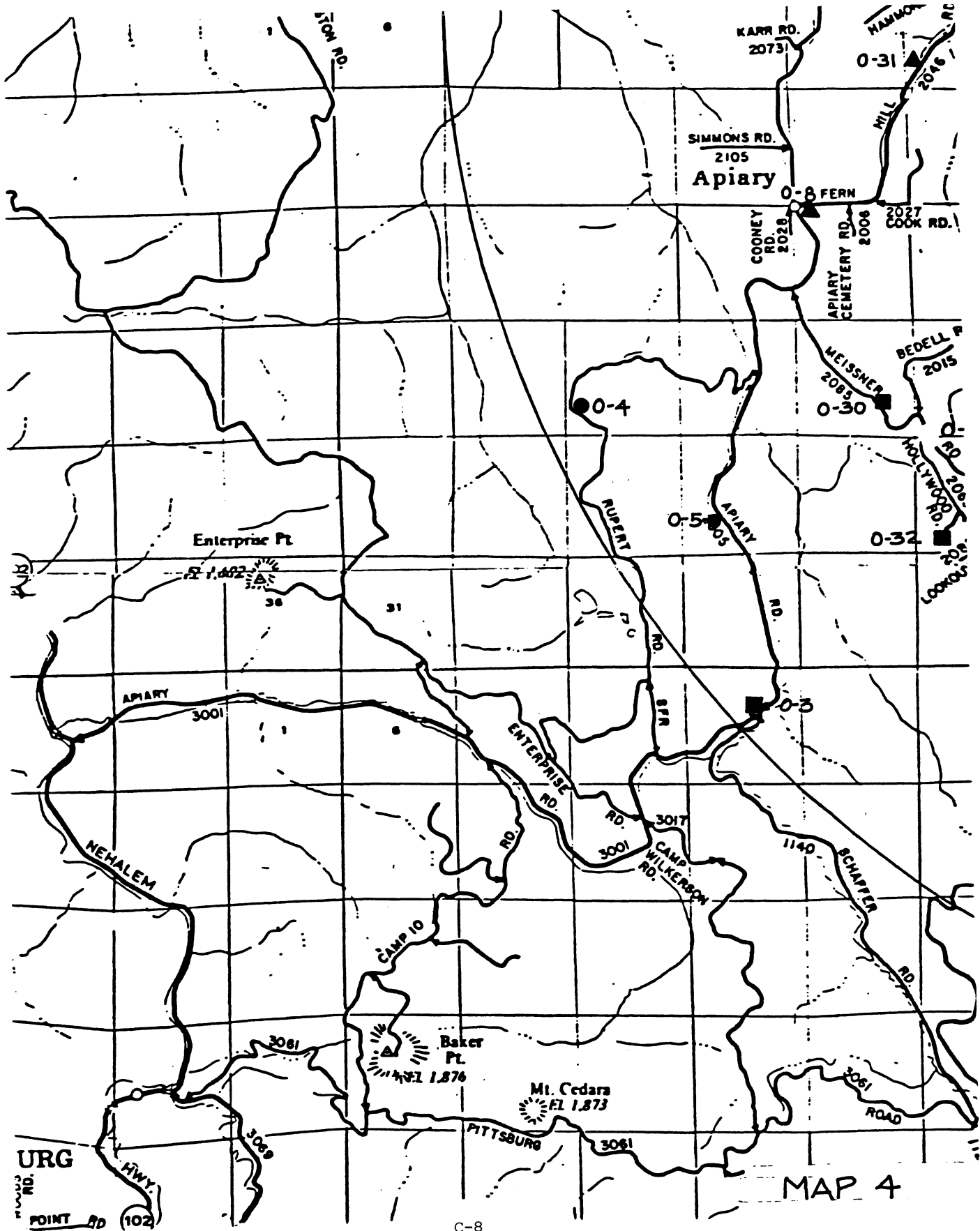

MAP 4

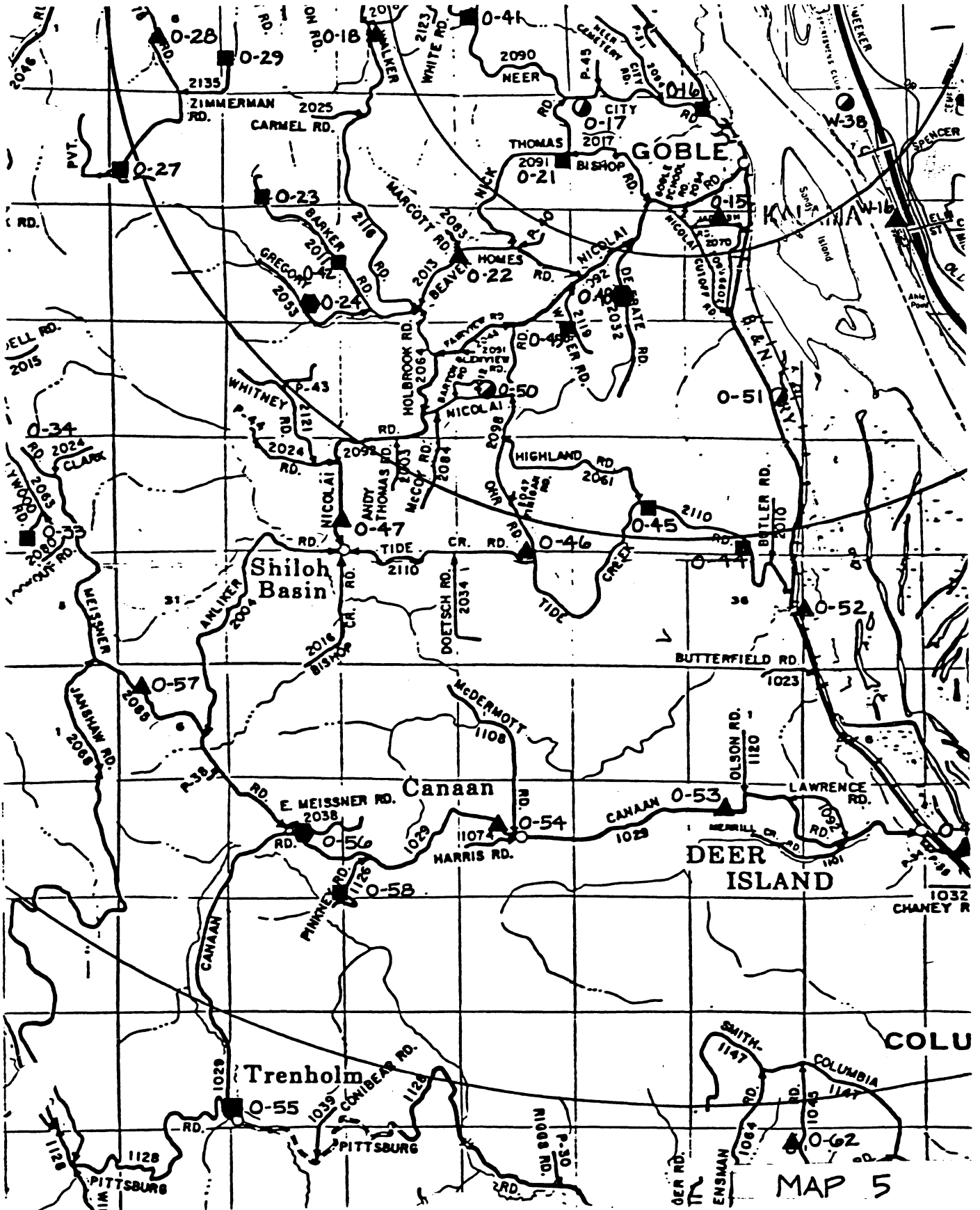

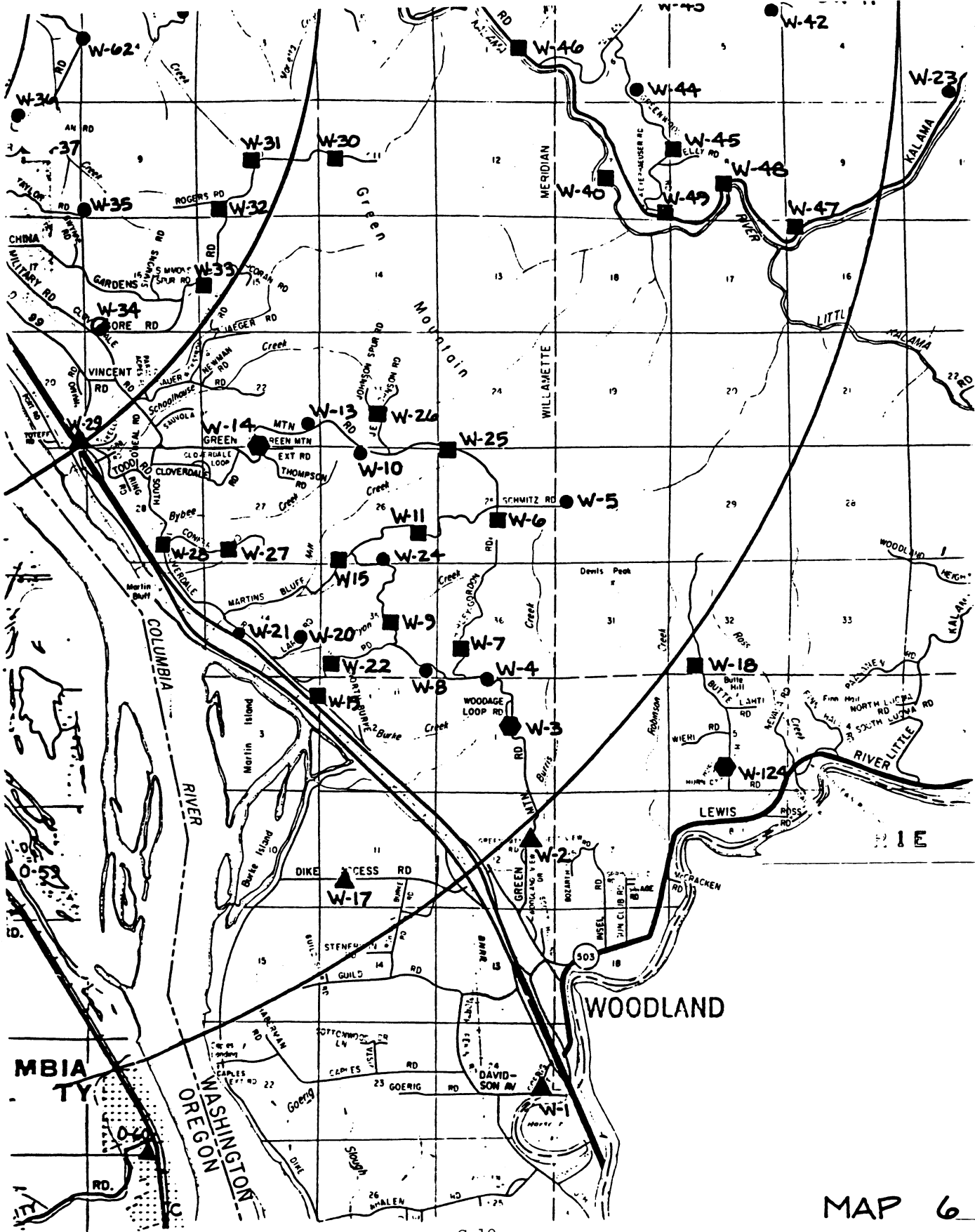

MAP 6

TABLE C.1. TROJAN SIREN INFORMATION.

Siren No.	Location (Map No.)	Rated SPL (dB @ 100 ft)	Type*
0-1	1	125	R
0-2	2	125	R
0-3	4	102	S
0-4	4	86	S
0-5	4	86	S
0-6	1	125	R
0-7	1	125	R
0-8	4	125	R
0-9	2	125	R
0-10	2	107	S
0-11	2	125	R
0-12	2	125	R
0-13	1	125	R
0-14	1	125	R
0-15	5	125	R
0-16	5	102	S
0-17	5	115	S
0-18	5	125	R
0-19	2	125	R
0-20	2	125	R
0-21	5	102	S
0-22	5	125	R
0-23	5	102	S
0-24	5	107	S
0-25	1	102	S
0-26	2	107	S
0-27	5	102	S
0-28	5	125	R
0-29	5	102	S
0-30	4	102	S
0-31	4	125	R
0-32	4	102	S
0-33	5	86	S
0-34	5	115	S
0-35	2	107	S
0-36	2	102	S
0-37	2	102	S
0-38	2	86	S
0-39	2	102	S
0-40	2	102	S
0-41	5	102	S
0-42	5	102	S

*Rotating (R) or Stationary (S)

TABLE C.1. TROJAN SIREN INFORMATION (Cont.).

Siren No.	Location (Map No.)	Rated SPL (dB @ 100 ft)	Type*
0-43	5	125	R
0-44	5	102	S
0-45	5	102	S
0-46	5	125	R
0-47	5	125	R
0-48	5	107	S
0-49	5	102	S
0-50	5	115	S
0-51	5	115	S
0-52	5	125	R
0-53	5	125	R
0-54	5	125	R
0-55	5	102	S
0-56	5	107	S
0-57	5	125	R
0-58	5	102	S
0-59	6	125	R
0-60	6	125	R
0-61	3	102	S
0-62	5	125	R
W1	6	125	R
W2	6	125	R
W3	6	102	S
W4	6	86	S
W5	6	86	S
W6	6	102	S
W7	6	102	S
W8	6	86	S
W9	6	102	S
W10	6	86	S
W11	6	102	S
W12	2	102	S
W13	6	86	S
W14	6	107	S
W15	6	102	S
W16	5	125	R
W17	6	125	R
W18	6	102	S
W19	6	102	S
W20	6	86	S
W21	6	86	S

*Rotating (R) or Stationary (S)

TABLE C.1. TROJAN SIREN INFORMATION (Cont).

Siren No.	Location (Map No.)	Rated SPL (dB @ 100 ft)	Type*
W22	6	102	S
W23	6	102	S
W24	6	86	S
W25	6	102	S
W26	6	102	S
W27	6	102	S
W28	6	102	S
W29	6	125	R
W30	6	102	S
W31	6	102	S
W32	6	102	S
W33	6	102	S
W34	6	115	S
W35	6	86	S
W36	6	86	S
W37	6	102	S
W38	5	115	S
W39	2	125	R
W40	6	102	S
W41	6	86	S
W42	6	86	S
W43	3	102	S
W44	6	86	S
W45	6	102	S
W46	6	102	S
W47	6	102	S
W48	6	102	S
W49	6	102	S
W50	3	102	S
W51	3	107	S
W52	3	86	S
W53	3	86	S
W54	3	102	S
W55	3	86	S
W56	3	107	S
W57	3	86	S
W58	3	102	S
W59	3	107	S
W60	3	86	S
W61	3	86	S
W62	6	86	S

*Rotating (R) or Stationary (S)

TABLE C.1. TROJAN SIREN INFORMATION (Cont.)

Siren No.	Location (Map No.)	Rated SPL (dB @ 100 ft)	Type*
W63	2	102	S
W64	2	107	S
W65	2	102	S
W66	3	102	S
W67	3	102	S
W68	3	102	S
W69	3	102	S
W70	3	102	S
W71	3	102	S
W72	2	115	S
W73	2	102	S
W74	3	102	S
W75	3	107	S
W76	2	107	S
W77	2	125	R
W78	3	102	S
W79	3	102	S
W80	3	102	S
W81	3	107	S
W82	3	107	S
W83	3	102	S
W84	3	102	S
W85	3	107	S
W86	3	86	S
W87	3	102	S
W88	3	102	S
W89	2	102	S
W90	2	125	R
W91	2	102	S
W92	2	102	S
W93	3	107	S
W94	3	86	S
W95	2	102	S
W96	2	102	S
W97	2b	125	R
W98	2b	125	R
W99	2	115	S
W100	2b	102	S
W101	2b	102	S
W102	2b	125	R
W103	2b	125	R

*Rotating (R) or Stationary (S)

TABLE C.1. TROJAN SIREN INFORMATION (Cont.)

Siren No.	Location (Map No.)	Rated SPL (dB @ 100 ft)	Type*
W104	2b	125	R
W105	2b	125	R
W106	2b	107	S
W107	2b	125	R
W108	2b	125	R
W109	2	125	R
W110	2a	125	R
W111	2a	125	R
W112	2a	125	R
W113	2a	125	R
W114	2a	125	R
W115	2a	125	R
W116	2a	125	R
W117	2a	125	R
		5	R

TABLE C.1. TROJAN SIREN INFORMATION (Cont.)

Siren No.	Location (Map No.)	Rated SPL (dB @ 100 ft)	Type*
W104	2b	125	R
W105	2b	125	R
W106	2b	107	S
W107	2b	125	R
W108	2b	125	R
W109	2	125	R
W110	2a	125	R
W111	2a	125	R
W112	2a	125	R
W113	2a	125	R
W114	2a	125	R
W115	2a	125	R
W116	2a	125	R
W117	2a	125	R
W118	2a	125	R
W119	2a	125	R
W120	2b	107	S
W121	2a	102	S
W122	2a	102	S
W123	2a	102	S
W124	6	107	S

*Rotating (R) or Stationary (S)

APPENDIX D: ESTIMATION OF A_{ATM}

The speed of sound in air increases with the square root of the absolute temperature. When the atmosphere is in motion, the speed of sound is the vector sum of its speed in still air and the wind speed. The temperature and wind in the atmosphere near the ground are almost never uniform. Hence, atmospheric nonuniformity produces gradients of the speed of sound, and thus refraction (bending) of sound wave paths. Near the ground, this refraction can have a major effect on the apparent attenuation of sound propagated through the atmosphere.

For the purpose of this procedure we have assumed a horizontally stratified atmosphere in which temperature and wind speed vary only with the logarithm of height above the ground. During the daytime, temperature normally decreases with height (lapse), so that sound waves from a source near the ground are refracted upwards. In the absence of wind, an "acoustic shadow" forms around the source (Fig. D-1a) into which no direct sound waves can penetrate. Marked attenuations are observed at receiving points well into the shadow zone - it is just as if a solid barrier had been built around the source. At night a temperature increase with height is common near the ground (inversion) and our "barrier" disappears as in Fig. D-1b.

Near the ground, wind speed almost always increases with height. Because the speed of sound is the vector sum of its speed in still air and the wind vector, a shadow zone can form upwind of the source, but is suppressed downwind (Fig. D-1c).

The combined effects of wind and temperature are usually such as to create acoustic shadows upwind of a source, but not downwind. Only under rare circumstances will a temperature lapse be sufficient to overpower wind effects and create a shadow

PATHS OF
SOUND WAVES

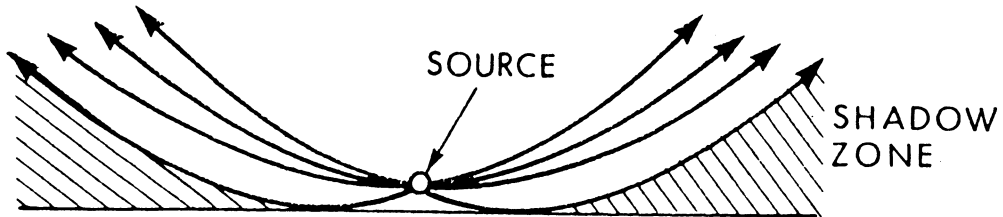

a. TEMPERATURE DECREASING WITH HEIGHT
Typical Daytime

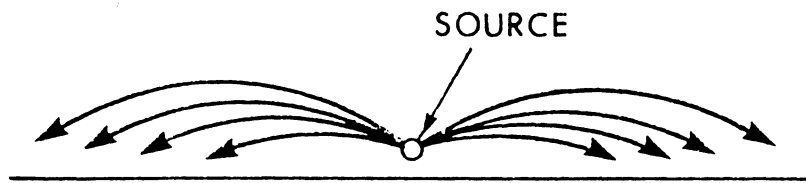

b. TEMPERATURE INCREASING WITH HEIGHT
Typical Nighttime

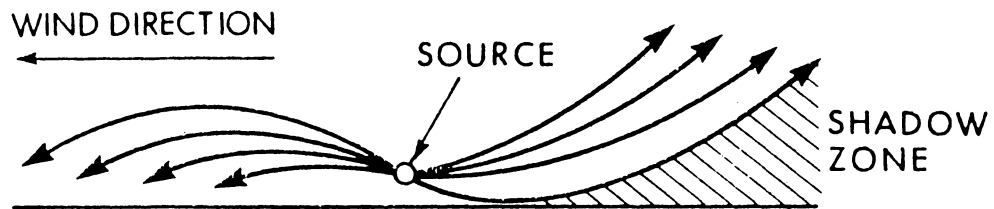

c. WIND SPEED INCREASING WITH HEIGHT
ABOVE THE GROUND

FIG. D-1. SKETCHES ILLUSTRATING THE EFFECTS OF VERTICAL TEMPERATURE AND WIND GRADIENTS IN FORMING ACOUSTIC SHADOW ZONES.

surrounding a source. It is less rare, but still uncommon for a surface inversion to be sufficiently strong to entirely overcome an upwind shadow.

The general situation is illustrated in plan view on Fig. D-2. A shadow boundary, symmetrical about the wind vector, can exist in the upwind direction from a sound source when the vertical wind gradient effect predominates over any effect caused by a temperature inversion. It is likely that no shadow will exist downwind from the source, for the wind gradient will usually overcome the effect of any temperature lapse. Along a radius at an angle ϕ_c from the wind vector, the shadow boundary (theoretically) approaches an infinite distance from the source.

In the "upwind" sector of Fig. D-2, the sound wave paths are generally concave upwards, as on the right side of Fig. D-1c. In the "downwind" sector, they are generally concave downwards, as on the left side of Fig. D-1c. In the "crosswind" direction, the sound wave paths are approximately straight lines from the source to the receiver.

For the purposes of this propagation model, we have assumed that temperature in the atmosphere, T , is horizontally uniform and varies with the logarithm of height above the ground, z .*

$$T \approx a \ln z$$

$$T = \frac{T_2 - T_1}{\ln h_2 - \ln h_1} = \frac{\Delta T}{\ln h_2 - \ln h_1} \quad (D-1)$$

and

$$\frac{\partial T}{\partial z} = az^{-1}$$

*This approximation is generally valid close to the ground except during strong surface-based temperature inversions [1,2].

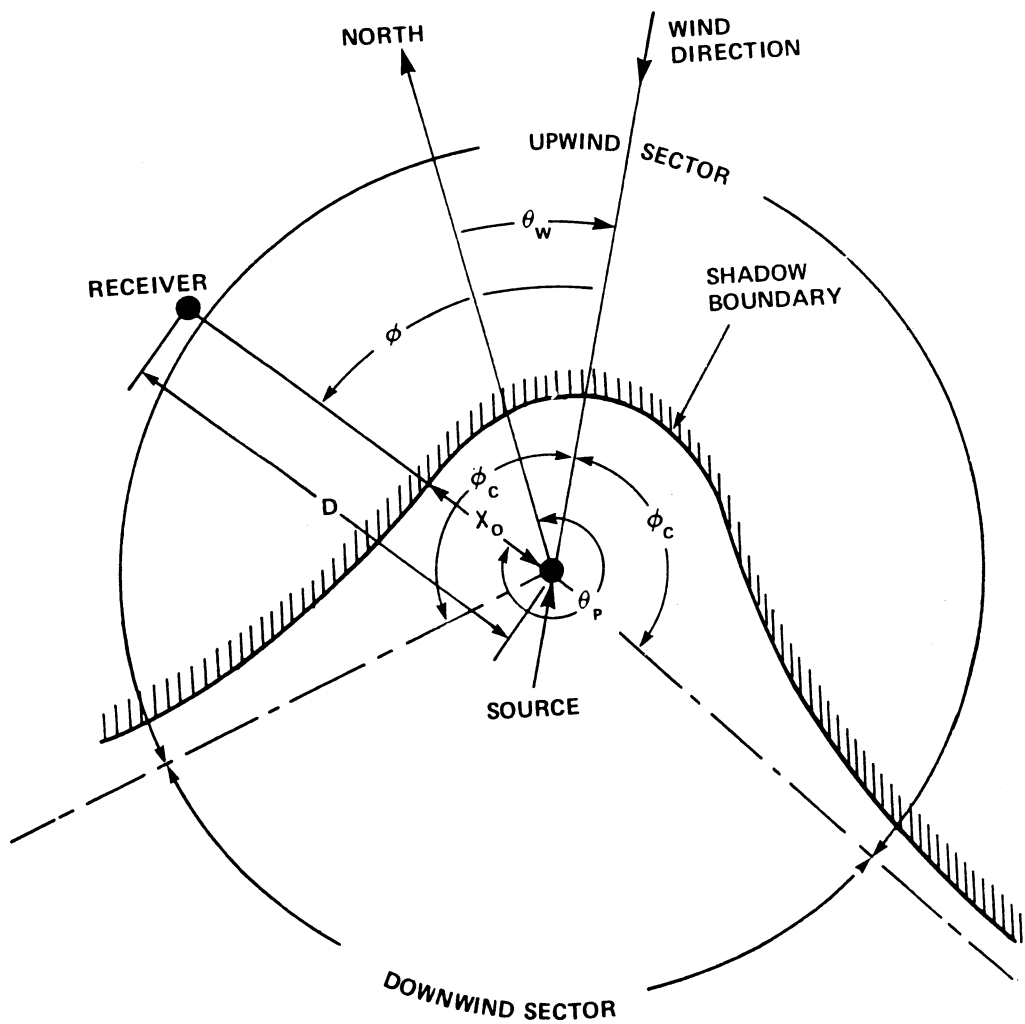

FIG. D-2. PLAN VIEW OF SOUND PROPAGATION SECTORS, WITH PARAMETERS USED TO DESCRIBE THEM (see text).

The speed of sound, c , varies directly with the square root of the absolute temperature

$$c = c_0 \left[\frac{T_0 + a (\ln z - \ln z_0)}{T_0} \right]^{1/2} \approx c_0 \left[1 + \frac{a (\ln z - \ln z_0)}{2T_0} \right]$$

where c_0 is the speed of sound at some reference temperature, T_0 , observed at a reference height of z_0 . Thus, the vertical gradient of the speed of sound due to temperature, α , is:

$$\frac{\partial c}{\partial z} \equiv \alpha = \frac{c_0}{2T_0} a z^{-1} \approx 1.086 a z^{-1} \text{ sec}^{-1} \text{ in English units} \quad (\text{D-2})$$

Note that α can be positive (inversion) or negative (lapse).

Likewise, we assume that the vertical profile of wind speed, β , varies only with the logarithm of height, z , so that:*

$$\beta \equiv \left[\frac{V_2 - V_1}{\ln h_2 - \ln h_1} \right] z^{-1} \quad (\text{D-3})$$

where V_2 is the speed of height h_2 and V_1 is the speed of height at h_1 . Note that β is always assumed to be positive.

The combined gradient of the speed of sound, C , resulting from both the temperature and wind gradients is thus

*This is a shakier simplification than that for the temperature profile [1], and normally holds only for near-neutral conditions [3]. The actual shape of the wind profile is a function of surface roughness, and of vertical momentum transfer due to thermal instability.

$$C = z(\beta \cos \phi - \alpha) \quad (D-4)$$

where ϕ is the angle between the direction from which the wind is coming and the sound path (Fig. D-2).

Each sound path can be classified as "upwind", or "downwind" for a given sample of meteorological data, on the basis of the following steps.

a. If α is positive and greater than β ($\alpha > \beta$; so that C would be negative for all values of ϕ), then no shadow zone can exist and all paths are classified as "downwind". This is the strong-inversion, low-wind condition.

b. If α is negative and numerically larger than β (i.e., $|\alpha| > \beta$, so that C would be positive for all values of ϕ), then the shadow zone completely surrounds the source and all paths are classified as "upwind". This is the strong-lapse, low-wind condition.

c. If $|\alpha| < \beta$, then the "critical angle", ϕ_c , (where temperature, and wind effects cancel) is calculated by setting $C = 0$ in Eq. D-4

$$C = z(\beta \cos \phi_c - \alpha) = 0$$

$$\phi_c = \cos^{-1} \frac{\alpha}{\beta} \quad (D-5)$$

where $0 \leq \phi_c \leq 180^\circ$

It is now necessary to do some coordinate transformations of the azimuthal data, entered relative to true North, to bearings relative to the direction from which the wind blows. Refer to Fig. D-2. The wind-sound angle, ϕ , is:

$$\phi = \left| \theta_p - \theta_w \right|, \text{ or if } \left| \theta_p - \theta_w \right| > 180^\circ:$$

$$\phi = 360 - \left| \theta_p - \theta_w \right| \quad (D-6)$$

Examine the difference $\phi_c - \phi$:

If $\phi < \phi_c$ then the path is a "upwind" path.

If $\phi > \phi_c$ then the path is a "downwind" path.

It is clear that this simplified model does not take into consideration some common effects, such as changes of wind direction with height and location and upper level inversions, which can lead to significant sound propagation to distances quite remote from a source.

Computing the Distance to the Shadow-Zone Boundary, X

Nyborg and Mintzer [4] have derived an expression for the distance, X_0 (See Fig. D-2), from a sound source to the boundary of its shadow zone at the height of the receiver, R, ft above local ground, and in the presence of a vertical sound velocity gradient which varies with the logarithm of height. Their work has been adapted for this procedure in the following form:

$$X_0 = S \sqrt{\frac{2c_0}{c}} \cdot f\left(\frac{R}{S}\right) \text{ feet}$$

$$\approx \frac{47S}{\sqrt{c}} \cdot f\left(\frac{R}{S}\right) \text{ in English units} \quad (D-7)$$

where S is the effective source height in feet above local ground, and the function $f\left(\frac{R}{S}\right)$ is obtained from Table D.1. The distance X_0 is in feet and is assumed to be frequency-independent.

TABLE D.1. $f(\frac{R}{S})$ vs $\frac{R}{S}$ for computing X_0 in Eq. (E-7).
 (after Nyborg and Mintzer [4]).

R/S	f(R/S)
≤ 0.05	0.4
0.1	0.45
0.2	0.55
0.3	0.6
0.4	0.7
0.5	0.75
0.7	0.85
0.9	1.0
1	1.05
1.5	1.25
2	1.5
3	1.9
4	2.3
5	2.65
6	3.0
7	3.3
8	3.65
9	3.95
10	4.2
> 10	Set $X_0 > D$

Interpolation is permitted, and for manual computations a graph of $f(R/S)$ vs. R/S is most useful.^{5/}

TABLE D.2. ATTENUATION WITHIN THE SHADOW ZONE, A_{atm} , VS SIREN-TO-LISTENER DISTANCE, D , FT.

$D \leq 1.2 X_0$	0 dB
$1.2 X_0 < D \leq 1.7 X_0$	5
$1.7 X_0 < D \leq 2.4 X_0$	10
$2.4 X_0 < D \leq 3.4 X_0$	15
$D > 3.4 X_0$	20

Attenuation within the Shadow Zone, A_u

Theoretically, the attenuation within a shadow zone can be arbitrarily large for large distances beyond the shadow boundary. In practice, more than 25-30 dB is rarely observed because the loss of sound energy from the direct waves is partially replaced by the energy of indirect waves scattered from turbulence, ground surface roughness, etc.

In this procedure, we have used representative values derived from the experimental work of Parkin and Scholes [6,7] and Weiner and Keast [8]. The recommended values (Table 2 of the main text) have an upper limit of 20 dB. Attenuation because of a shadow zone has occasionally been observed to decrease somewhat at extreme distances relative to closer-in distances. The conservative values in Table D.2 allow for this possibility.

**REFERENCES
TO APPENDIX D**

1. Keast, D.N. and F.M. Wiener, "An Empirical Method for Estimating Wind Profiles over Open, Level Ground", Trans. Am. Geophys. Union 39, (5), pp. 858-864, October 1958.
2. Sutton, O.G., Micrometeorology, McGraw-Hill Book Co., London, Sect. 6.4, p. 206, 1953.
3. Ibid, Sect. 7.2, p. 232 et seq.
4. Nyborg, W.L. and D. Mintzer, "Review of Sound Propagation in the Lower Atmosphere", WADC Technical Report 54-602, Sect. 1.5.5, p.50 et seq., May 1955.
5. Ibid, Fig. 16, p. 54.
6. Parkin, P.H. and W.E. Scholes, "The Horizontal Propagation of Sound from a Jet Engine Close to the Ground, at Radlett", J. Sound and Vibration, 1, pp. 1-15, 1964.
7. Parkin, P.H. and W.E. Scholes, "The Horizontal Propagation of Sound from a Jet Engine Close to the Ground, at Hatfield", J. Sound and Vibration, 2 (4), pp. 353-374, 1965.
8. Wiener, F.M. and D.N. Keast, "Experimental Study of the Propagation of Sound Over Ground", J. Acoust. Soc. Am., 31 724-733, 1959.

APPENDIX E: DEPENDENCE OF ALERT UPON SIREN DURATION

In the main body of this report, the chances of alert are predicted for a four-minute period of siren operation (here called siren duration). In this appendix, predictions are generalized for longer and shorter siren durations. This appendix will allow readers to convert four-minute results to results for other siren durations.

This appendix begins with an overview of the relationship between siren level and siren duration, and how this relationship affects the chances of alert. It continues with development of the mathematics of this relationship, and then summarizes results for the reader's use.

E.1 Overview

Table E.1 is a typical "chance-of-alert" table for a particular background-noise environment. Siren durations are listed across the top, and siren levels down the left side. Within the table are the chances of alert -- from 100 down to zero percent. In the main body of this report, results are based upon the four-minute columns of tables such as this one.* Variations within the table are related to fluctuating background noise in the listener's environment.**

*And upon the one-minute columns for rotating sirens.

**Precision within Table E.1 degrades for longer siren durations (to the right) and for lower siren levels (to the bottom). For longer siren durations, precision suffers from the limited amount of total data that underlie the table. These data include 250 minutes of background noise, which is only about eight times the longest siren duration. For lower siren levels, precision suffers from the very small percentage of time that these low siren levels will alert the listener. Although the amount of data is large compared to the siren durations, the background noise is rarely low enough to contribute to the statistics at these low siren levels. For longer siren durations and lower siren levels combined, the precision is particularly bad.

TABLE E.1. TYPICAL CHANCE-OF-ALERT TABLE FOR A PARTICULAR BACKGROUND-NOISE ENVIRONMENT.

SIREM LEVEL	SIREM DURATION (MINUTES)															
	1	2	3	4	5	6	7	8	9	10	11	12	13	14	15	16
74	100	100	100	100	100	100	100	100	100	100	100	100	100	100	100	100
73	99	100	100	100	100	100	100	100	100	100	100	100	100	100	100	100
72	99	99	100	100	100	100	100	100	100	100	100	100	100	100	100	100
71	98	99	100	100	100	100	100	100	100	100	100	100	100	100	100	100
70	99	99	100	100	100	100	100	100	100	100	100	100	100	100	100	100
69	98	99	100	100	100	100	100	100	100	100	100	100	100	100	100	100
68	97	99	100	100	100	100	100	100	100	100	100	100	100	100	100	100
67	97	99	100	100	100	100	100	100	100	100	100	100	100	100	100	100
66	95	98	100	100	100	100	100	100	100	100	100	100	100	100	100	100
65	92	96	98	98	98	100	100	100	100	100	100	100	100	100	100	100
64	92	95	98	98	98	100	100	100	100	100	100	100	100	100	100	100
63	89	92	95	97	96	100	100	100	100	100	100	100	100	100	100	100
62	87	91	94	95	95	98	100	100	100	100	100	100	100	100	100	100
61	85	90	94	95	95	98	100	100	100	100	100	100	100	100	100	100
60	85	90	93	95	95	98	100	100	100	100	100	100	100	100	100	100
59	83	87	90	92	94	95	100	97	100	100	100	100	100	100	100	100
58	81	86	90	92	94	95	100	97	100	100	100	100	100	100	100	100
57	79	83	88	89	90	93	94	94	95	95	95	95	100	94	100	93
56	78	82	87	88	89	90	94	94	95	95	95	95	100	94	100	93
55	74	79	82	83	84	86	89	87	89	92	91	90	95	89	94	87
54	70	73	81	83	84	86	89	87	89	92	91	90	95	89	94	87
53	68	76	80	81	84	86	89	87	89	92	91	90	95	89	94	87
52	65	75	77	78	82	83	86	84	89	88	87	90	85	89	94	87
51	60	70	74	75	78	81	83	81	86	84	83	85	89	83	88	80
50	55	65	70	71	74	79	81	81	82	80	83	85	84	83	81	80
49	51	61	67	68	70	76	78	81	79	80	83	85	84	83	81	80
48	48	57	63	65	66	71	75	74	75	76	78	81	79	83	75	80
47	42	54	60	63	64	71	75	71	75	76	74	81	78	83	75	80
46	37	47	54	57	58	67	69	68	71	72	70	76	74	78	69	73
45	33	44	50	56	56	64	67	65	71	68	70	76	68	73	69	73
44	33	43	50	56	56	64	67	65	71	68	70	76	68	73	69	73
43	30	40	45	54	52	57	64	65	68	68	70	71	68	73	69	73
42	25	33	37	41	42	48	50	55	57	56	57	62	58	61	56	60
41	21	28	35	38	40	45	50	55	57	56	57	62	58	61	56	60
40	18	24	30	33	34	38	42	48	46	44	52	57	53	50	50	60
39	14	20	24	28	30	36	36	42	43	40	48	52	47	44	50	60
38	12	17	20	25	28	33	33	39	43	40	48	48	47	44	50	53
37	10	15	19	22	24	31	31	35	39	36	43	43	47	44	50	53
36	8	12	14	16	18	21	22	26	29	24	30	29	32	33	31	33
35	7	9	10	11	12	14	14	16	18	16	17	19	21	22	19	20
34	6	8	8	10	10	12	11	13	14	16	17	19	16	17	13	13
33	6	8	8	10	10	12	11	13	14	16	17	19	16	17	13	13
32	6	8	8	10	10	12	11	13	14	16	17	19	16	17	13	13
31	6	8	9	10	10	12	11	13	14	16	17	19	16	17	13	13
30	6	7	7	8	8	10	8	10	11	12	13	14	11	11	13	13
29	6	7	7	8	8	10	8	10	11	12	13	14	11	11	13	13
28	5	6	6	6	6	7	6	6	7	8	9	10	5	6	6	7
27	4	6	5	6	6	7	6	6	7	8	9	10	5	6	6	7
26	4	6	5	6	6	7	6	6	7	8	9	10	5	6	6	7
25	3	5	5	6	6	7	6	6	7	8	9	10	5	6	6	7
24	2	4	5	6	6	7	6	6	7	8	9	10	5	6	6	7
23	1	2	4	5	0	7	6	0	7	0	9	10	0	6	0	0

In this table, the chance of alert is 100 percent when the siren level is much higher than the background noise could ever be at the listener. When the siren level is 74 dB, for example, the siren will definitely alert the listener even for siren durations as short as one minute.

The chance of alert is zero percent when the siren level is low, say 20 dB or less, no matter how long the siren sounds. The background noise is always sufficient to mask (acoustically cover up) such low siren levels.

For siren signals of intermediate levels, the chance of alert falls between 100 and zero percent, in the detailed manner shown. These intermediate details follow from the fluctuations of the background noise, from minute to minute.

For these intermediate siren levels, the chance of alert increases with siren duration as indicated in the table. For a siren level of 50 dB, for example, the chance of alert is 71 percent if the siren is sounded for four minutes. If this duration is doubled to eight minutes, the chance of alert increases to 81 percent.

How can this increase with duration be understood mathematically? If such understanding results in a particular mathematical pattern, then this pattern can be used to convert four-minute results to results for other siren durations. The search for this mathematical pattern is the subject of the next section.

E.2 Development of the Mathematics

The search for patterns within tables of numbers is necessarily an exploratory matter. First, some underlying mathematics must be postulated, and then a numerical pattern must be sought with this mathematics as guidance. Once a preliminary pattern is

discovered, it must be simplified to be of use, and then must be generalized for other similar tables. Ideally, the pattern will emerge as a simple equation, with a small number of adjustable constants.

The steps involved in developing such a pattern are:

- preparation
- underlying mathematics and its simplification
- exploratory graphs, guided by the mathematics
- simplification and generalization to all other tables.

These steps are discussed next.

E.2.1 Preparation

Figure E-1 shows typical background noise as it fluctuates over a one-minute period. The fluctuations are generally large, as shown here. In this background noise, a listener will be alerted by a siren whenever it is 9 decibels or more above the background noise level.* The figure shows a siren that produces a steady 49 dB at the listener. A dashed line 9 dB below the siren level denotes the alerting threshold. During the shaded time intervals below this threshold, the siren will alert the listener.

*Throughout this appendix, background noise includes the noise in a 1/3-octave frequency band centered at 630 Hz, a typical siren operating frequency. Dictated by the physiology of the ear, only this 1/3-octave band is available to mask, or cover up, the pure-tone signal of typical sirens. Siren levels are usually measured as overall sound levels, though the same values would be measured using only a 1/3-octave frequency band filter.

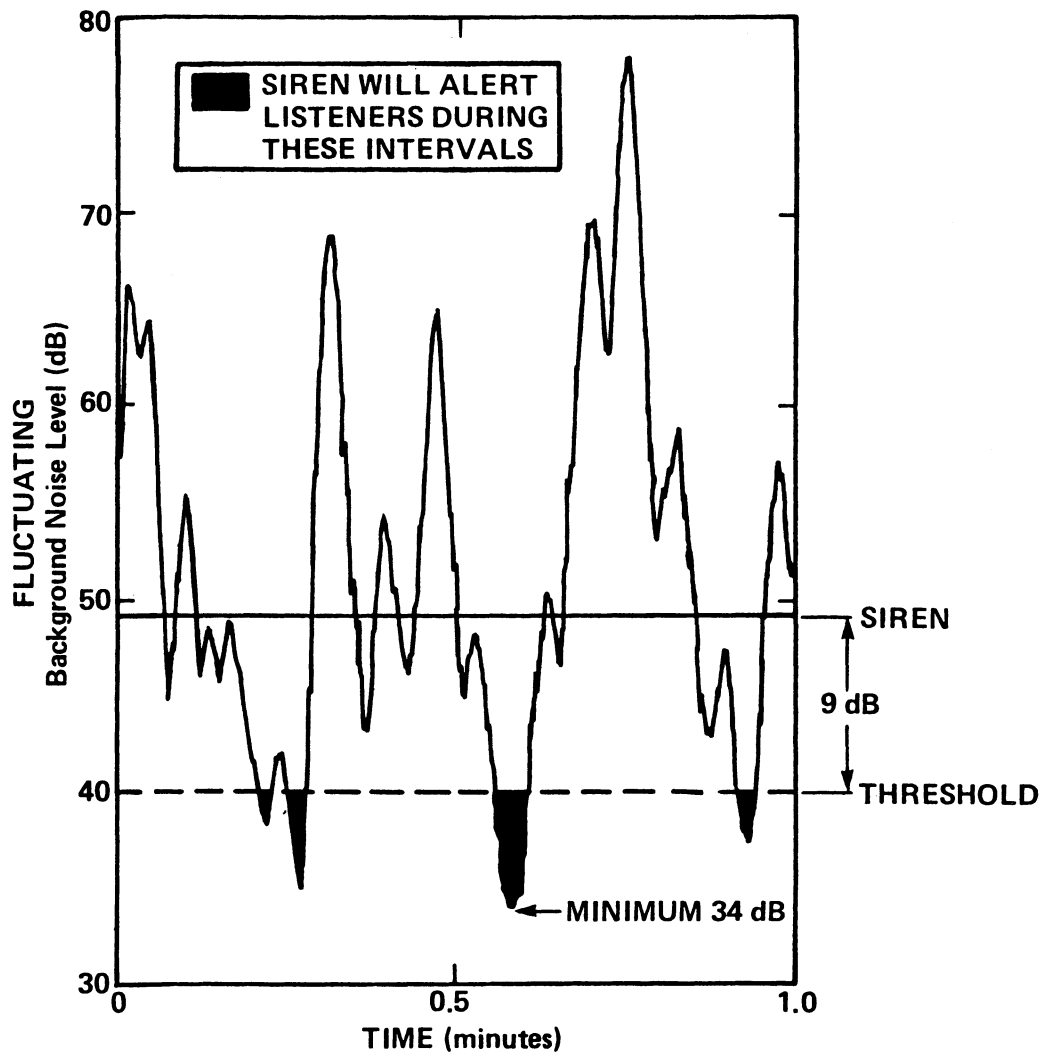

FIG. E-1. BACKGROUND NOISE LEVEL AS A FUNCTION OF TIME.

This siren level has succeeded in alerting the listener during its one-minute duration. However, a siren level some 7 decibels lower would not alert because the background noise would always be above its lowered threshold line of 33 dB.

This figure suggests another way to phrase the alerting question. Instead of asking if the siren is loud enough to cause alert, one could ask: For a given siren level, is the background noise ever low enough to allow alert? Since the background noise is continually fluctuating, this question is inherently a statistical question. Its answer depends upon the statistics of the background noise fluctuations.

The answer to the above question is: Yes, alert will occur during this one-minute period if

$$(L_{\text{background}})_{\text{minimum}} \leq L_{\text{siren}} - 9\text{dB}$$

Otherwise, the siren will fail to alert the listener. The only statistic of interest, therefore, is the minimum background noise level during this one-minute period.*

Figure E-2 shows a series of one-minute minima for forty successive one-minute time periods. Every minute's minimum is different, as the figure shows. These 40 minima were measured over a 40-minute time period, and are part of a much larger set (approximately 250) of total data. For the siren level shown, 35

*Our analysis for this study actually utilized the 90-percentile background noise level, rather than the minimum level. The 90-percentile noise level is the level exceeded 90 percent of the time; the remaining 10 percent of the noise falls below this level. Use of the 90-percentile noise level adds a measure of conservatism to the results, since it requires slightly higher siren levels before alert is predicted.

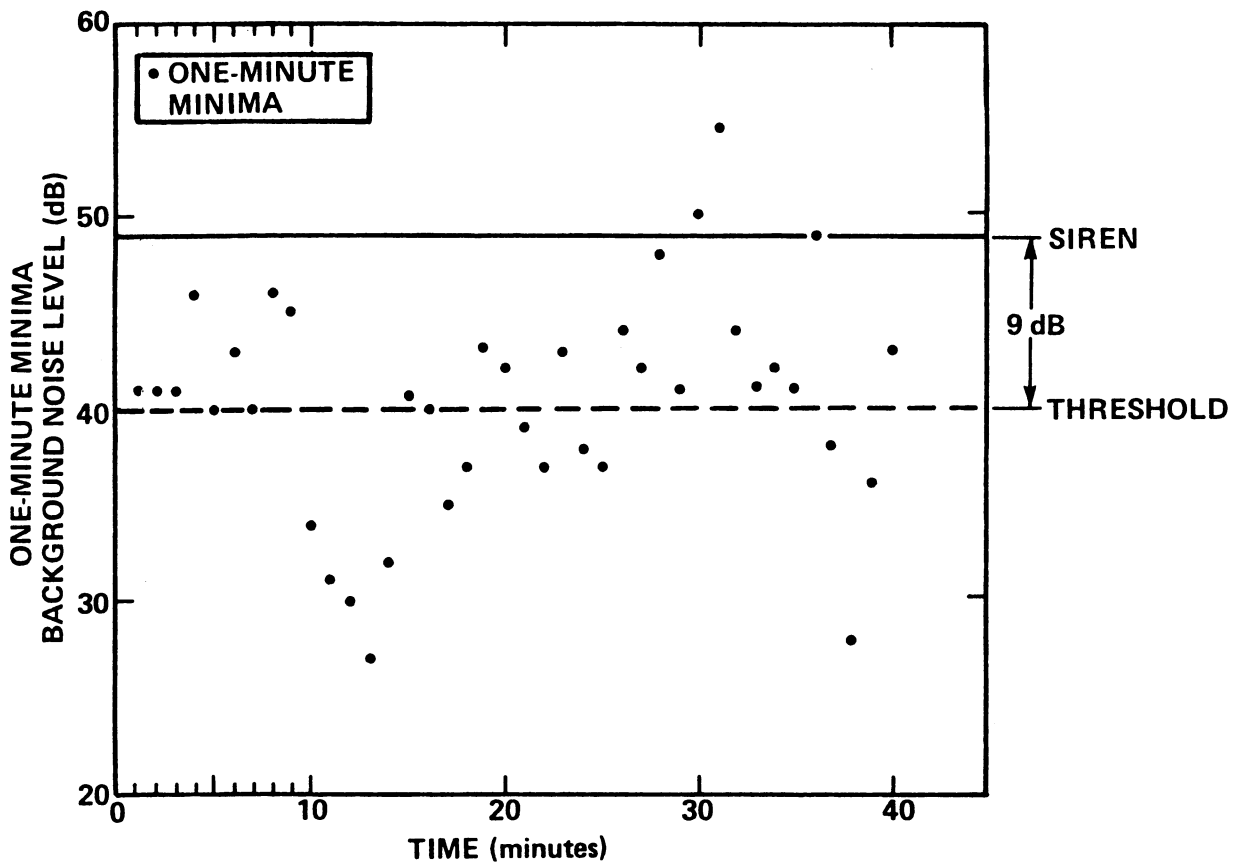

FIG. E-2. MINIMUM BACKGROUND NOISE LEVELS OBSERVED IN ONE-MINUTE INTERVALS FOR A 40-MINUTE TIME PERIOD.

percent of the minima (14 out of 40) fall below the threshold line. Therefore, this siren level in this background noise has a 35 percent chance of alert -- when sounded for a duration of one minute.

This plot applies only to sirens sounded for one minute, since the background-noise minima are one-minute minima. Stated another way, when a siren is sounded for one minute, it has an equal chance of encountering any of these forty one-minute time periods, which represent all one-minute periods. During 35 percent of these minutes it will alert the listener, since the noise falls below the alerting threshold at least once during those minutes.

Next, say that the siren is sounded for four minutes. Figure E-3 shows the four-minute minima of interest -- as circled dots. Each of these is just the lowest of four one-minute minima in each four-minute grouping. Of these four-minute minima, 60 percent (6 out of 10) fall below the threshold line. Therefore, this siren level in this background noise has a 60 percent chance of alert when sounded for a duration of four minutes. Note that the chance of alert has increased with the siren duration.

Needed is mathematics that relates the one-minute chance of alert to the four-minute chance, and to the chances for all other siren durations as well. This mathematics is based upon probabilities P , rather than upon "chances." A 35 percent chance of alert is equivalent to a probability P of 0.35. Moreover, this mathematics is based upon the probability of failure to alert, rather than success in alerting.

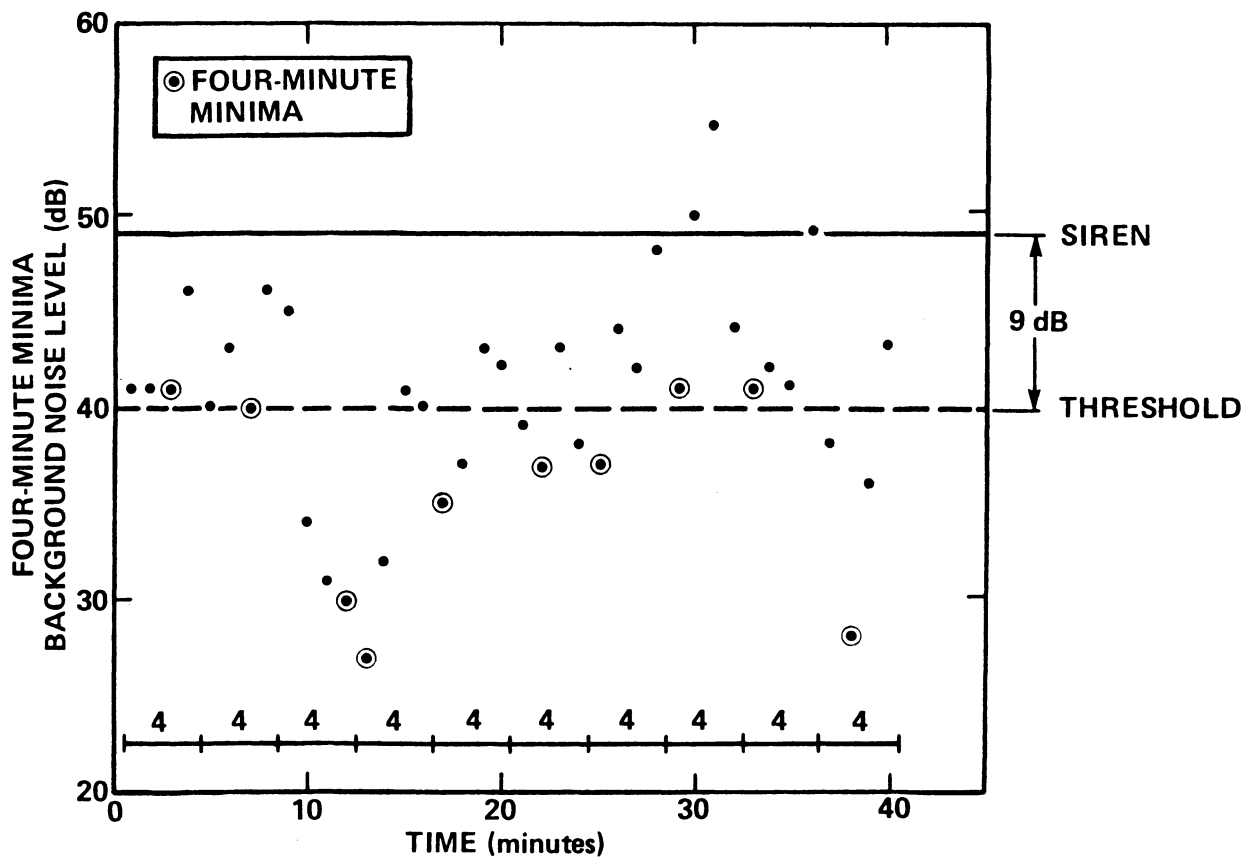

FIG. E-3. MINIMUM NOISE LEVELS OBSERVED IN FOUR-MINUTE INTERVALS FOR A 40-MINUTE TIME PERIOD (from Fig. E-2).

Chance of Success	Probability	
	of Success	of Failure
100%	1.0	0
80%	0.8	0.2
60%	0.6	0.4
40%	0.4	0.6
20%	0.2	0.8
0%	0	1.0

Note that

$$P_{\text{failure}} = 1 - P_{\text{success}}$$

and that failure occurs when minima points are above the threshold line.

E.2.2 Underlying Mathematics and its Simplification

Figure E-2 above contains one-minute minima for a total time period of forty minutes. All the points in this figure are collapsed onto the vertical axis in Figure E-4, at the left. They form a "cloud" of points denser at intermediate noise levels and sparser for higher and lower levels. This is a probability "cloud," in which area is proportional to the probability (density) of one-minute minima.

For any one-minute period, the probability of failure is proportional to the "cloud" area above the threshold line. This upper area, divided by the total cloud area, is the probability that the background noise will exceed the threshold level throughout any one-minute period -- that is, the probability that

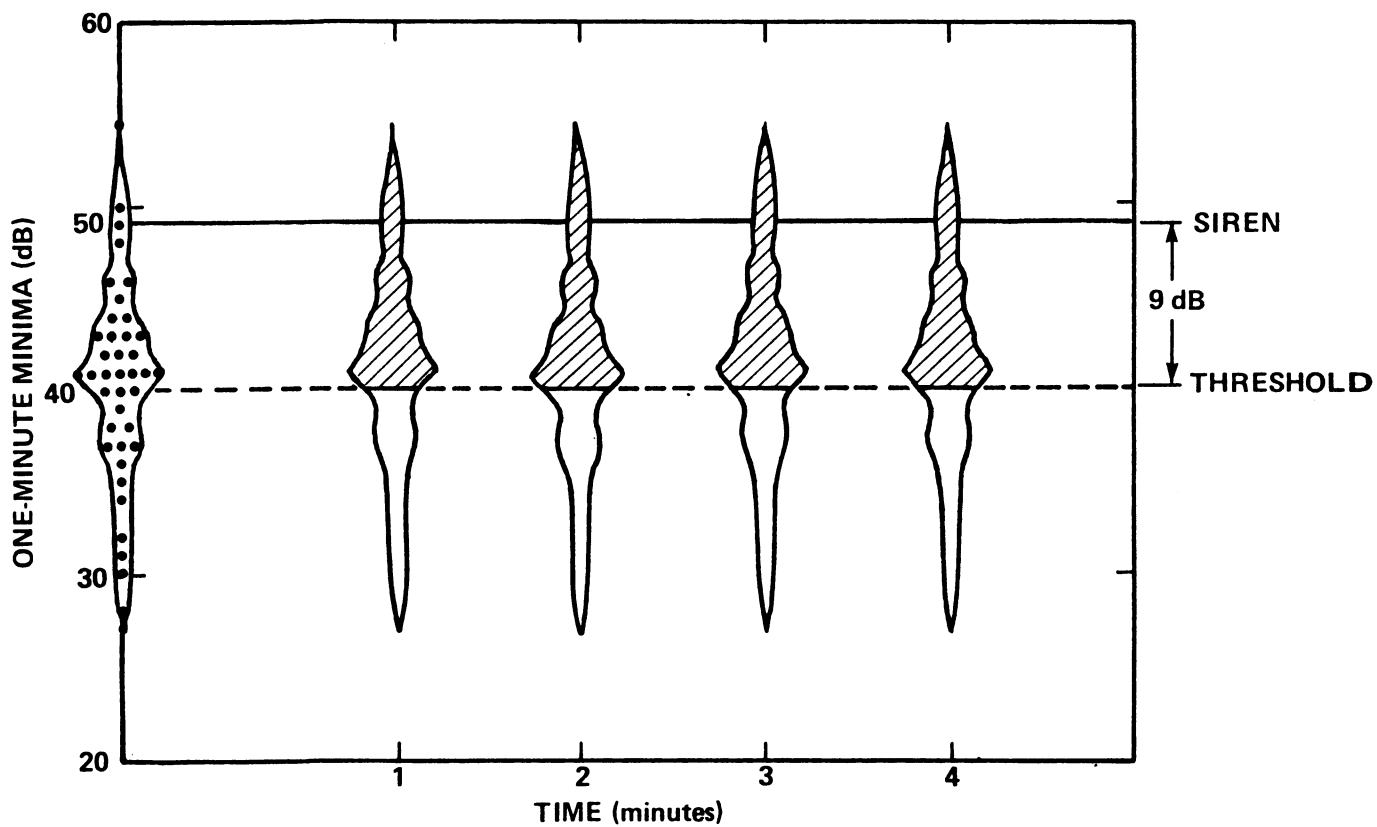

FIG. E-4. PROBABILITY "CLOUDS" FOR ONE-MINUTE BACKGROUND NOISE IN SUCCESSIVE MINUTES, ASSUMING EACH MINUTE IS STATISTICALLY INDEPENDENT OF ALL OTHER MINUTES.

the siren will fail to alert the listener. This one-minute probability of failure is $(1-0.35) = 0.65$ for the example shown.

To the right in the figure, this cloud is duplicated at each of four successive minutes. If we assume these four minutes to be independent of one another, this probability cloud would apply equally to all of them, as shown. Let us assume this to be the case for a moment. Then, for the siren to fail after four minutes, it must fail for each of the one-minute periods. Therefore, the probability of failure after four minutes is

$$\begin{aligned} P(4) &= (P_1)(P_2)(P_3)(P_4) \\ &= (P_1)^4 \end{aligned}$$

In this equation, $P(4)$ means the probability of failure after a total of four minutes have gone by, while P_4 means the probability of failure during the fourth minute only.*

This equation, however, is valid only if the one-minute periods are independent of one another. A glance at Figure E-2 above indicates that they are not independent. For example, for a one-minute period with a very low minimum, the following minute probably also has a low minimum. There is a regularity in the successive minima; they are not independent. For this reason, the cloud picture must be modified to that of Figure E-5.

In Figure E-5, the first minute's cloud is unchanged from that of Figure E-4. However, the second minute's cloud represents the conditional probability of: "failure during minute

*If we had worked with probabilities of success, combining four minutes into one equation would be far more complicated. That is why we choose to work with failure instead. As the very last step, we shall convert from failure back to success.

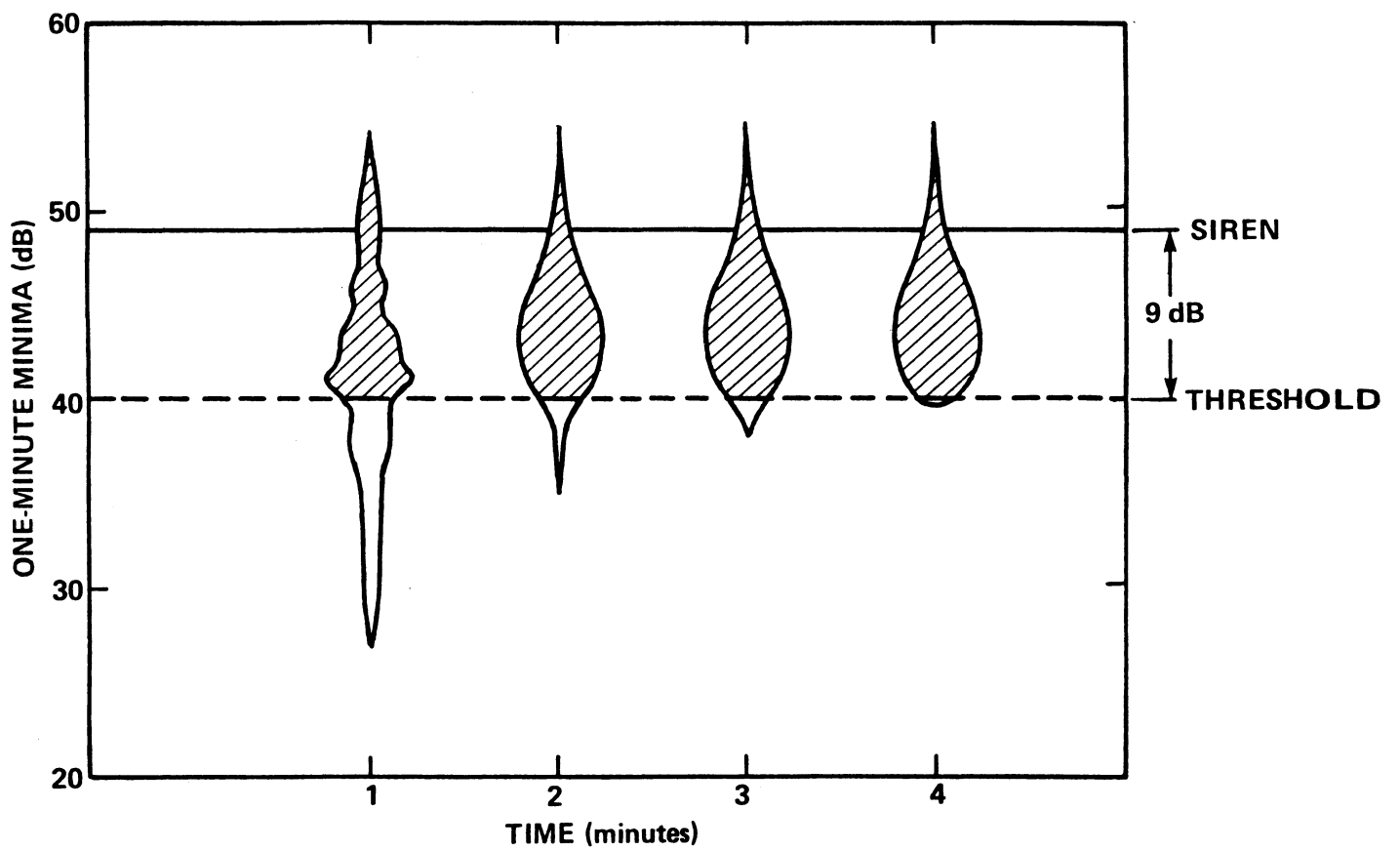

FIG. E-5. PROBABILITY "CLOUDS" FOR ONE-MINUTE BACKGROUND NOISE MINIMA IN SUCCESSIVE MINUTES, ASSUMING MINIMA IN SUCCESSIVE MINUTES ARE NOT INDEPENDENT.

two, given that failure occurred during minute one." In other words, the cloud at minute two represents the probability that the second minute's minimum will be above the threshold, given that the first minute's was also above the threshold. Mathematically, we write $P_{2:1}$ for this conditional probability. Then

$$P(4) = (P_1)(P_{3:1:2})(P_{4:1,2,3})$$

conditional probabilities

Note that $P_{2:1}$ is greater than the independent P_2 .

$$P_{2:1} > P_1$$

This increase is due to the regularity between successive minutes -- technically to the correlation between the successive minute's minima. The higher the correlation between successive minima, the more this probability cloud will condense above the threshold line. The remaining clouds condense even more above the line, since they are failure probabilities, given that several failures have preceded.

A short numerical example will be useful here. For no correlation, we have

$$P(4) = (0.65)(0.65)(0.65)(0.65)$$

$$P(4) = (0.65)^4 \approx 0.18$$

and therefore the probability of success is 0.82. For some correlation, we have

$$P(4) = (0.65)(0.8)(0.85)(0.9)$$

$$P(4) \approx 0.40$$

for a probability of success of 0.60. And for full correlation we have

$$\begin{aligned} P(4) &= (0.65)(1.0)(1.0)(1.0) \\ P(4) &= 0.65 \end{aligned}$$

for a probability of success of 0.35.

In general,

$$\begin{aligned} P(n) &= (P_1)(P_{2:1})(P_{3:1,2}) \cdots (P_{n:1,2,3,\dots,n-1}) \\ &= (P_1)^n \text{ for no correlation} && \text{(E-1)} \\ &= P_1 \text{ for full correlation.} \end{aligned}$$

The upper half of Figure E-6 illustrates graphically how the probability of failure thus decreases with increasing time -- that is, with increasing siren duration. The probability of success therefore increases with siren duration, as shown in the bottom half of the figure. (This figure is an example only, not a general result.)

Note for large correlation between successive minima, there is not as much benefit in sounding the siren longer. If the siren fails to alert during the first minute, it will most likely fail to alert thereafter, because the first minute is nearly identical to all subsequent minutes.

This underlying mathematics resides in Eq. E-1 above. In Eq. E-1, the notation $P_{n:1,2,3,\dots,n-1}$ reminds us that P_n is a conditional probability, which assumes the siren failed during

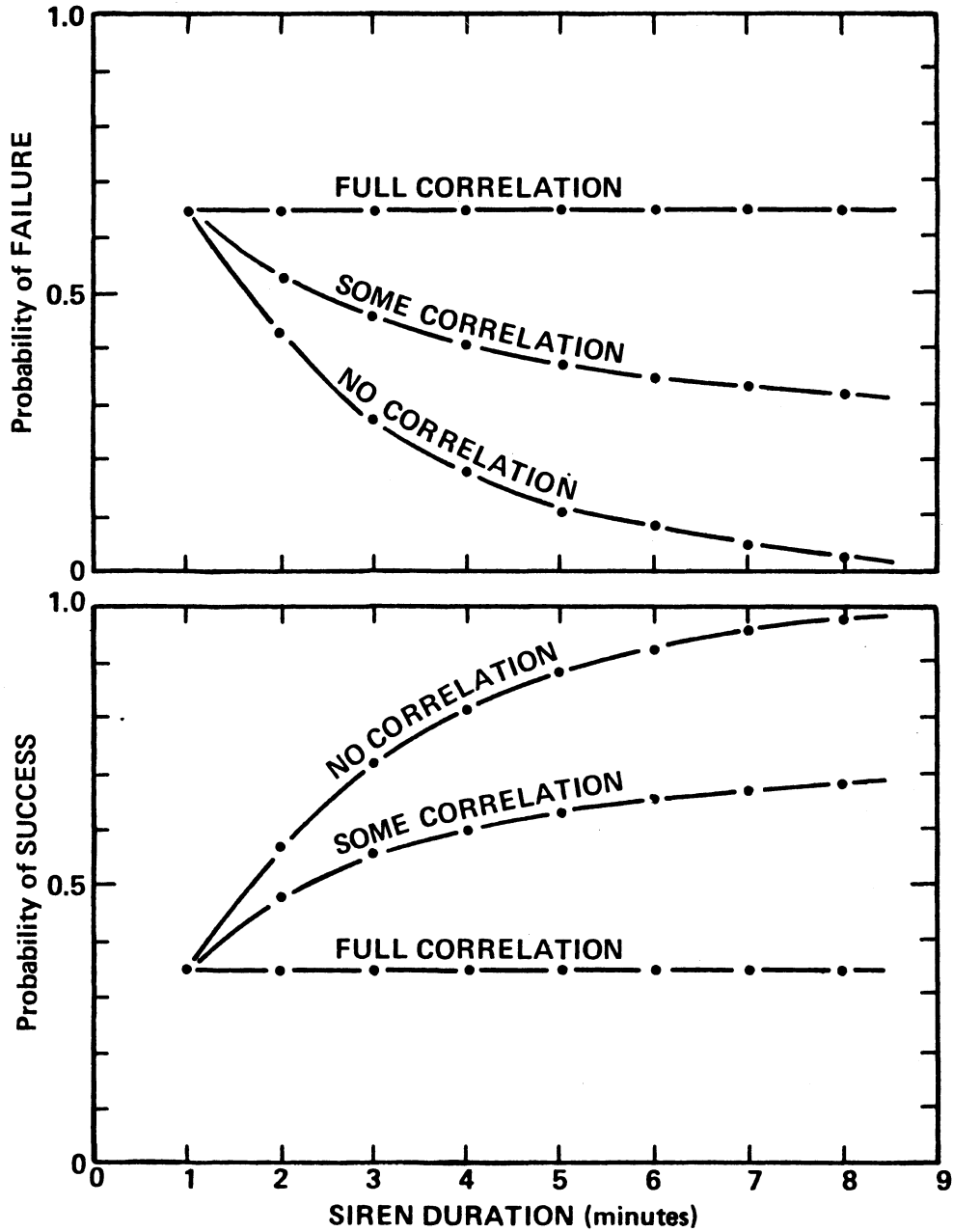

FIG. E-6. GRAPHIC ILLUSTRATION OF SIREN ALERTING PROBABILITIES VS. SIREN DURATION, FOR VARIOUS AMOUNTS OF CORRELATION BETWEEN BACKGROUND NOISE MINIMA IN SUCCESSIVE MINUTES (Example only).

all previous minutes. We next simplify, so that this P_n assumes failure only during the immediately preceding minute. Mathematically,

$$P_{n:1,2,3,\dots,n-1} = P_{n:n-1}$$

Let

$$P_{n:n-1} = CP_1$$

where C contains all the conditional aspects of the probability. The term P_1 is the unconditional probability for the first minute. Then

$$P(n) = (P_1)(CP_1)(CP_1) \dots (CP_1)$$

$$P(n) = P_1^n C^{n-1} \tag{E-2}$$

Note that for no correlation,

$$C = 1 \tag{E-3}$$

and therefore

$$P(n) = P_1^n$$

as before. For full correlation,

$$C = \frac{1}{P_1} \tag{E-4}$$

to make

$$\begin{aligned} P(n) &= P_1^n \left(\frac{1}{P_1}\right)^{n-1} \\ &= P_1 \end{aligned}$$

as before.

Eq. E-2 is the desired simplification. In the following section, we graph measured background data, to explore the nature of C, for correlations typically present in measured background noise data.

E.2.3 Exploratory Graphs, Guided by the Mathematics

To explore for C graphically, we first take the logarithm of Eq. E-2.

$$\begin{aligned} P(n) &= P_1^n C^{n-1} \\ \log P(n) &= n \log P_1 + (n-1) \log C \\ \log P(n) &= -\log C + n \left[\log CP_1 \right] \end{aligned} \quad (E-5)$$

If $\log P(n)$ is then plotted against n , the resulting straight line should have a vertical intercept of $-\log C$ and a slope of $\log CP_1$. After some curve-smoothing on linear paper, on Fig. E-7 we logarithmically plot part of the data in Table E.1 above. Each line is for a different representative siren level, labelled ① through ⑤ .

Of course, the linear curve-smoothing helped line up the points shown here. Even so, the regression fit to straight lines for each siren level is very good. Note however, that the vertical intercepts and the slopes vary from curve to curve. Therefore, C must vary with siren level.

We then set each intercept equal to $-\log C$ and each slope equal to $\log CP_1$, and solve for C and P_1 -- separately for each straight line.

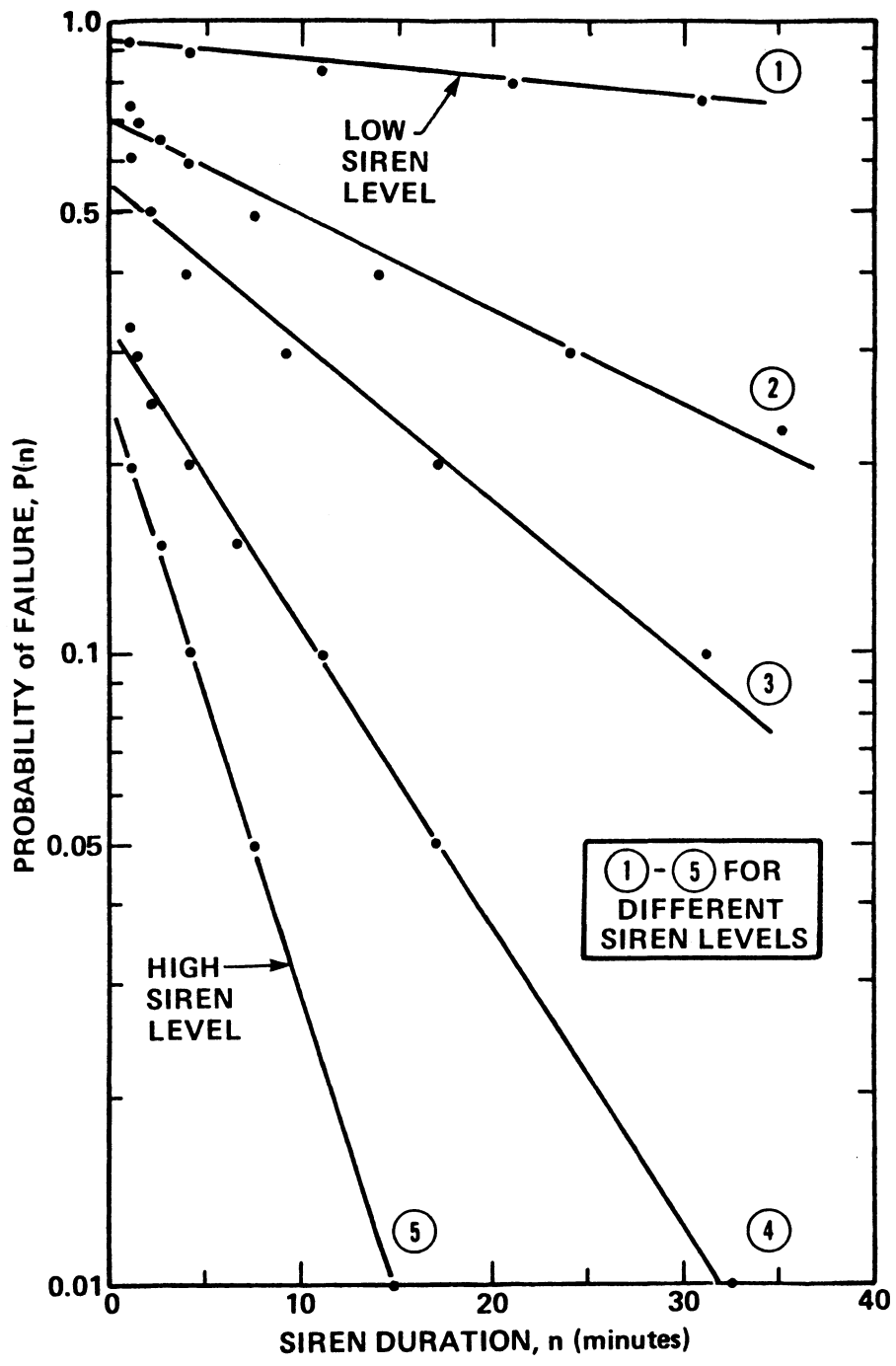

FIG. E-7. LOGARITHM OF THE PROBABILITY OF SIREN FAILURE-TO-ALERT VS. SIREN DURATION FOR FIVE DIFFERENT SIREN LEVELS, DERIVED FROM THE DATA IN TABLE E.1.

Line Number	C	P ₁
①	1.073	0.925
②	1.426	0.678
③	1.816	0.520
④	3.062	0.293
⑤	4.064	0.199

From Eq. E-4 above, we suspect that C may be a power function of P₁, and so we plot logC against logP₁ in Figure E-8. On this plot, the straight-line fit is also very good. It yields:

$$C = (P_1)^{-0.87}$$

It seems to make sense, based upon this limited analysis, to generalize to

$$C = (P_1)^{-\rho}$$

where ρ (rho) denotes a correlation coefficient. Zero correlation would then make

$$C = (P_1)^0 = 1$$

and full correlation would make

$$C = (P_1)^{-1} = \frac{1}{P_1}$$

These agree with Eqs. E-3 and E-4 above.

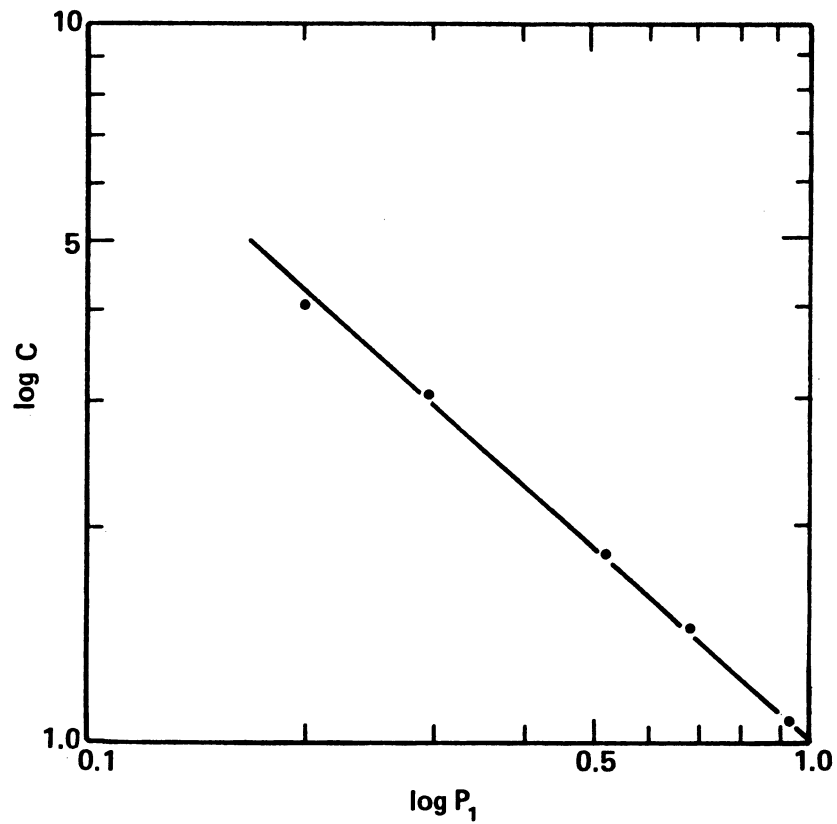

FIG. E-8. PLOT OF VALUES OF CUMULATIVE CONDITIONAL PROBABILITIES (LOG C) VS. PROBABILITY OF FAILURE IN THE FIRST MINUTE (LOG P₁), DERIVED FROM FIG. E-7.

In summary then, the time-pattern within Table E.1 can be written as

$$P(n) = (P_1)^{n-0.87(n-1)} = (P_1)^{0.87 + 0.13n} \quad (E-6)$$

The two constants in the exponent sum to 1.00, and depend upon correlation within the background noise, from minute to minute. Moreover, Eq. E-6 depends upon the siren level through P_1 , which varies with siren level.

Next, we simplify Eq. E-6 so it may be generalized to a wide variety of noise-level tables, not just Table E.1 above.

Eq. E-6 is valid for all siren levels, in the presence of the particular background noise used to develop Table E.1. Its general form is

$$\begin{aligned} P(n) &= (P_1)^n C^{n-1} \\ &= (P_1)^n (P_1)^{-\rho(n-1)} \\ &= (P_1)^{\rho + n(1-\rho)} \end{aligned} \quad (E-7)$$

In logarithmic form,

$$\begin{aligned} \log P(n) &= \left[\rho + n(1-\rho) \right] \log P_1 \\ &= \rho \log P_1 + n \left[(1-\rho) \log P_1 \right] \end{aligned} \quad (E-8)$$

With $\log P(n)$ plotted against n , this is the equation of a straight line with vertical intercept $\rho \log P_1$ and slope $(1-\rho)\log P_1$.

A normal regression fit would solve for the two variables ρ and P_1 , separately for each of the siren levels (as shown in Figure E-7, for instance). However, there is a relationship above that implies ρ to be a constant, independent of the siren level. Therefore, we wish to collapse all curves, for all siren levels, to a single curve. For this purpose, we manipulate Eq. E-8 as follows:

$$\log P(n) = \left[\rho + n(1-\rho) \right] \log P_1$$

$$\frac{\log P(n)}{\log P_1} = \rho + n(1-\rho)$$

$$= 1 + (n-1)(1-\rho) \quad (E-9)$$

Hence, plotting $(\log P(n)/\log P_1)$ against $(n-1)$ yields a straight line of intercept 1 and slope $(1-\rho)$, independent of siren level. In other words, each curve in Figure E-7 has been normalized to its value of P_1 , and all curves have been collapsed into one.

We will have need below for a similar equation, but normalized to the probability at four minutes, rather than at one minute. We develop this next.

In the graphs above, letter n was interpreted as progressing in one-minute steps ($n=1,2,3$ equals $t=1,2,3$). However, nothing in the mathematics requires this interpretation. Any time interval could be taken as the basic interval n above. In particular, the basic time interval could be taken as four minutes. Then four-minute minima ($n=1$) would combine into eight-minute minima ($n=2$), and so forth. The result would be Eq. E-9 above, but with

$$n = 4t \text{ (in minutes)}$$

and
$$P_1 = P_{(n=1)} = P_{(t = 4 \text{ minutes})}$$

Figure E-9 schematically compares these one-minute and four-minute normalizations.* For the one-minute normalization on top: $n=t$, and therefore $n-1 = t-1$, as shown on the first horizontal axis. Plotted horizontally is the range

$$0 \leq t - 1 \leq 3$$

$$1 \leq t \leq 4$$

The small plotted points represent the tabulated values for these four minutes, collapsed into one line by the P_1 normalization. The line is fit by linear regression and has slope $(1-\rho)$.

This upper portion of Figure E-9 is for rotating sirens. As explained in the main text, rotating sirens are less effective in alerting the public, since they produce their maximum siren level for only a portion of their duration. For this reason, four-minute results for rotating sirens are derived from the one-minute background-noise statistics. In the figure, the third horizontal scale shows the corresponding siren durations for rotating sirens. The normalization is therefore to a four-minute siren duration, and the graph extends up to a maximum of 16 minutes.

*Note that the lines in Figure E-9 rise rather than fall to the right, as does Figure E-7, for this reason: In Figure E-7, the actual logarithms on the vertical axis are negative, since the $P(n)$'s are less than unity. Therefore, this vertical axis actually decreases, from zero at the top to minus-two at the bottom. For increasing n , then, the curves take on increasingly large negative values (for example: $-1, -1.5, -2$). Figure E-9 is normalized by $\log P_1$, however, which is also negative, and which turns these increasingly negative values into increasingly positive values. Therefore, the lines rise in Figure E-9.

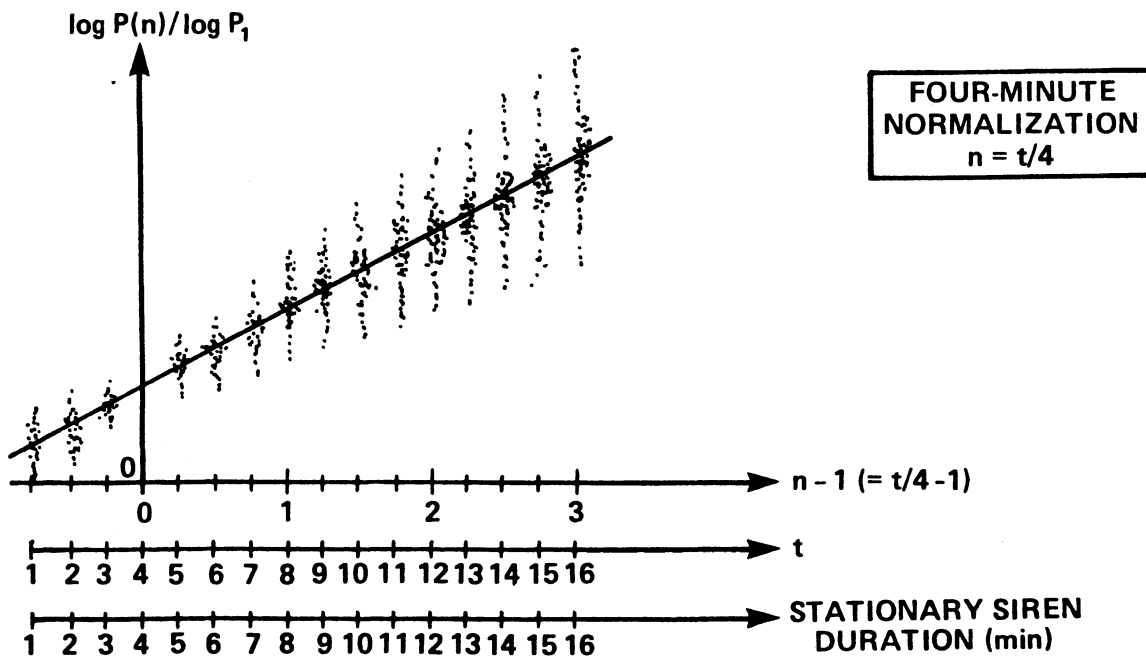
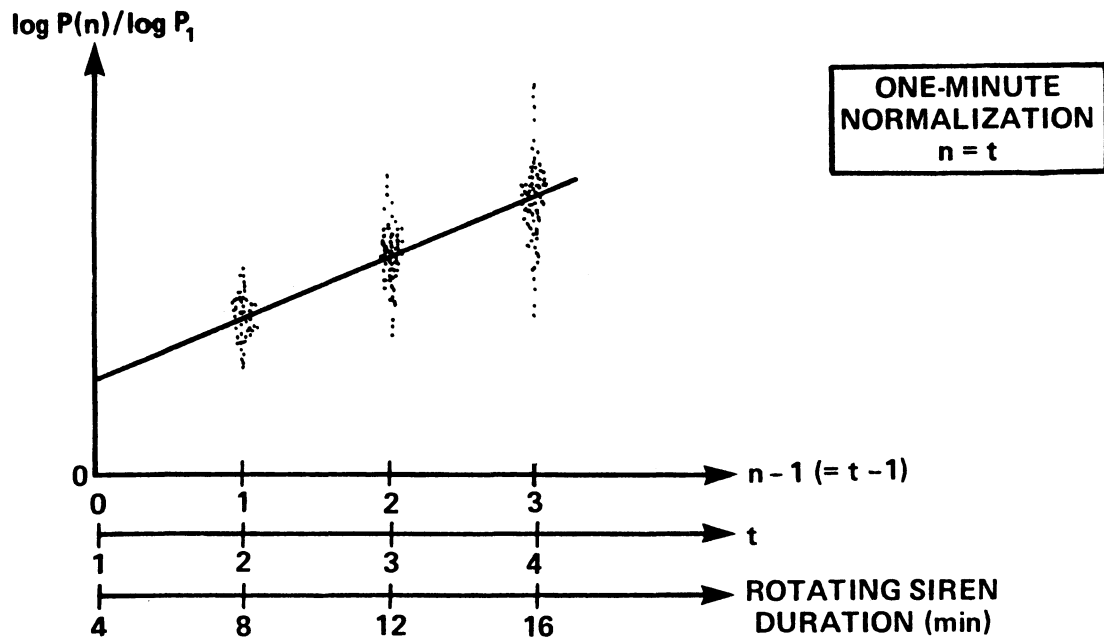

FIG. E-9. SKETCH OF ONE-MINUTE AND FOUR-MINUTE NORMALIZATIONS TO SHOW RELATIONSHIP BETWEEN VARIABLE N AND SIREN DURATIONS.

For the four-minute normalization at the bottom of the figure: $n = t/4$, and therefore $n-1 = t/4 - 1$, as shown. Plotted horizontally is the range

$$- \frac{3}{4} \leq \frac{t}{4} - 1 \leq 3$$

$$\frac{1}{4} \leq \frac{t}{4} \leq 4$$

$$1 \leq t \leq 16$$

The second horizontal scale shows time t and is identical to the third scale, which shows duration of stationary sirens. The normalization is therefore to a four-minute siren duration, and the graph extends up to a maximum duration of 16 minutes.

Using these equations and normalizations, the curve-fitting procedure was applied to six background-noise tables -- tables similar to Table E.1 above -- developed from data measured at 74 different indoor and outdoor locations. In this curve-fitting, no linear smoothing was used, and data from all siren levels were used without omission. Table E.2 contains the resulting slopes.

These slopes were next converted to ρ , assuming that they equal $(1-\rho)$, as labelled in the table. The resulting twelve values of ρ were plotted against the corresponding values R_{xx} of the auto correlation function, to obtain

$$R_{xx} = -0.034 + 1.051\rho$$

$$\approx \rho$$

This regression equation has a correlation coefficient (between values of ρ and r_{xx}) of 0.85, which is satisfactorily high.

In the next section, we collect these results into a form of use to the reader.

E.3 Summary of Results

Figure E-10 contains the results of the analysis above. This figure is used as follows:

- Convert the four-minute "chance of alert" to a probability of failure-to-alert":

$$P = 1 - (\text{Chance of alert})/100$$
- Raise this value to the exponent determined from Figure E-10, for the particular siren duration of interest.

$$P = (P_{4\text{-min}})^{\text{Exponent}} \quad (\text{E-10})$$
- Convert this "probability of failure-to-alert" back to a "chance of alert":

$$\text{Chance of alert} = 100 (1-P)$$

TABLE E.2. SLOPES RESULTING FROM SIREN LEVEL DATA.

Listener Location	Subclass	Resulting Slopes (1-ρ)	
		Stationary Sirens	Rotating Sirens
Indoors	Scenario 1	0.217	0.142
	Scenario 3	0.274	0.254
Outdoors	Rural, day	0.164	0.177
	Urban, day	0.065	0.103
	Rural, eve/night	0.150	0.075
	Urban, eve/night	0.046	0.039

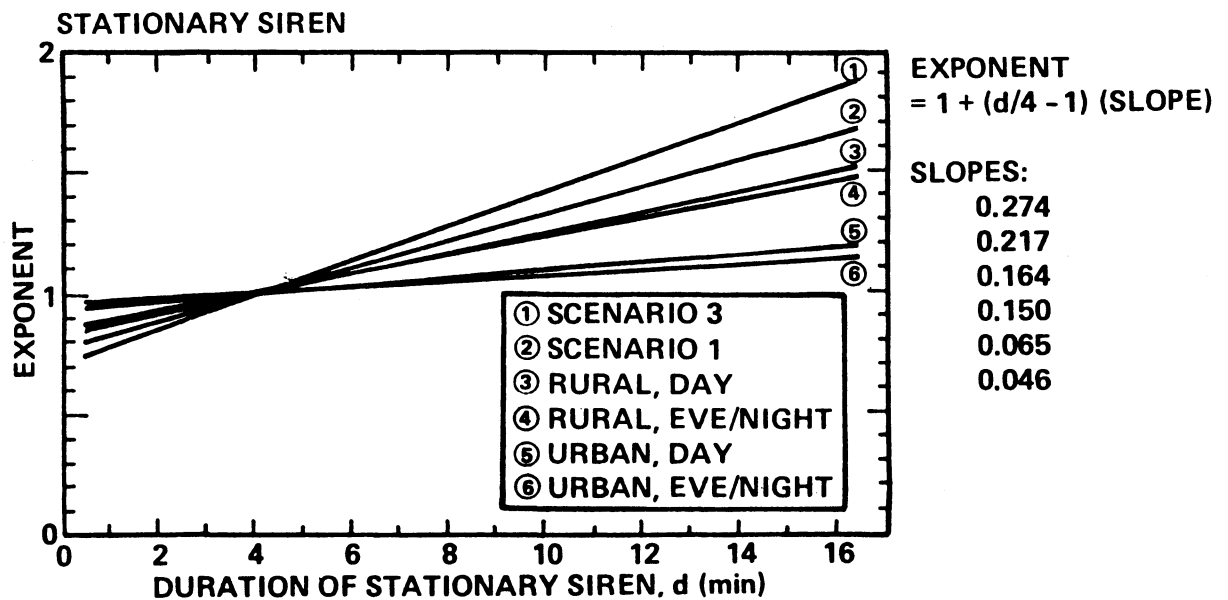
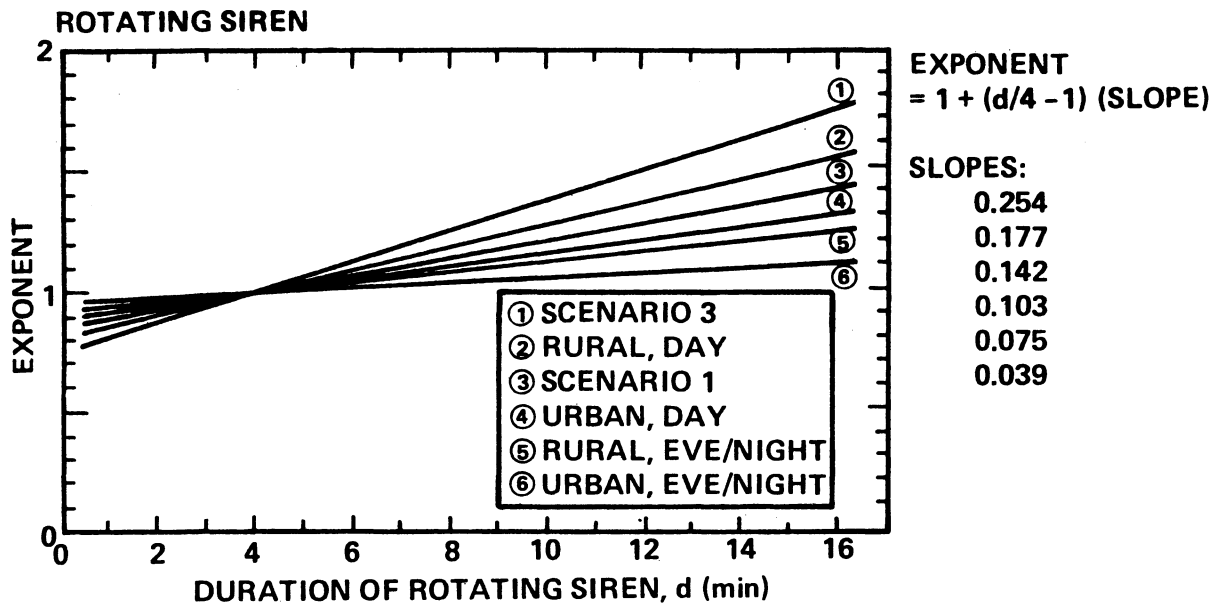

FIG. E-10. GRAPH OF EXPONENT FOR USE IN EQ. E-10.

APPENDIX F. RANDOM SELECTION OF POPULATION-WEIGHTED LISTENING POINTS AT THE THREE MILE ISLAND SITE

The objective of the listener-site-selection process was to identify 50 randomly selected residential locations within the 10-mile EPZ surrounding the TMI Nuclear Plant. No arbitrary decision was made as to how many of the points would lie in urban or rural areas or within certain distances of the plant.

The various steps used in the site selection procedure are described below:

1. A population-distribution map (see Fig. F-1), consisting of a 10-mile-radius circle divided into annular sectors defined by interior circles and radii, was superimposed on the U.S.G.S. maps. Population distribution information consisted of the number of people within each annular sector. These data were used in order to population-weight the random selection process described below.
2. Each annular sector was first assigned a designator, such as a letter. A range of numbers was then assigned to each sector according to the population in that sector. For example, Sector A, just north of the site, has a population of 19 and thus was assigned numbers 1 through 19. Sector B (moving clockwise) has a population of 55 and was assigned numbers from 20 to 74. Sector C has a population of 42 and was assigned numbers 75 through 116. This process was continued until each number between 1 and 166,295 (the total estimated population) was assigned to a particular sector. A ran-

dom number generator (available on a Texas Instruments Model TI-59 hand calculator, for example) was then used to select 50 numbers at random between 1 and 166,295. Each number selected represented one site (to be chosen later) within the sector containing that number. Thus, sectors with larger populations had a greater possibility of including chosen listener sites.

3. Having determined the sector locations for each listener site, the next step in the procedure involved selecting the actual location of each site within the respective sector. This was accomplished by first overlaying a rectangular coordinate grid on each sector of interest on the topographic map. The grid was composed of boxes with dimensions of approximately 1000 feet square, and each box was assigned an X and a Y coordinate according to its location on the grid. The grid was positioned such that the X-axis was oriented in the east-west direction and the Y-axis was oriented in the north-south direction, and such that all parts of the sector of interest were covered by a positive (X,Y) coordinate pair box. A random number generator was then used to select random pairs of numbers within the X and Y ranges covering the sector of interest. Each X,Y pair was used to locate a particular 1000 feet square box on the map. If there were no residences inside the square or if the square fell outside of the sector of interest, that coordinate pair was disregarded and another pair was chosen at random. This process was continued until a square area including one or more residential structures was found in the sector of

interest. The listener site was then chosen to be any residence within the randomly selected square area.

For urban sites in the pink "building-extension" area of the topographic map a residential building was always assumed to exist, and was selected at the center of the pink area in the 1000 feet square box.

The above procedure resulted in a random sample of 50 listener locations, distributed throughout the EPZ as shown roughly on Fig. F-1.

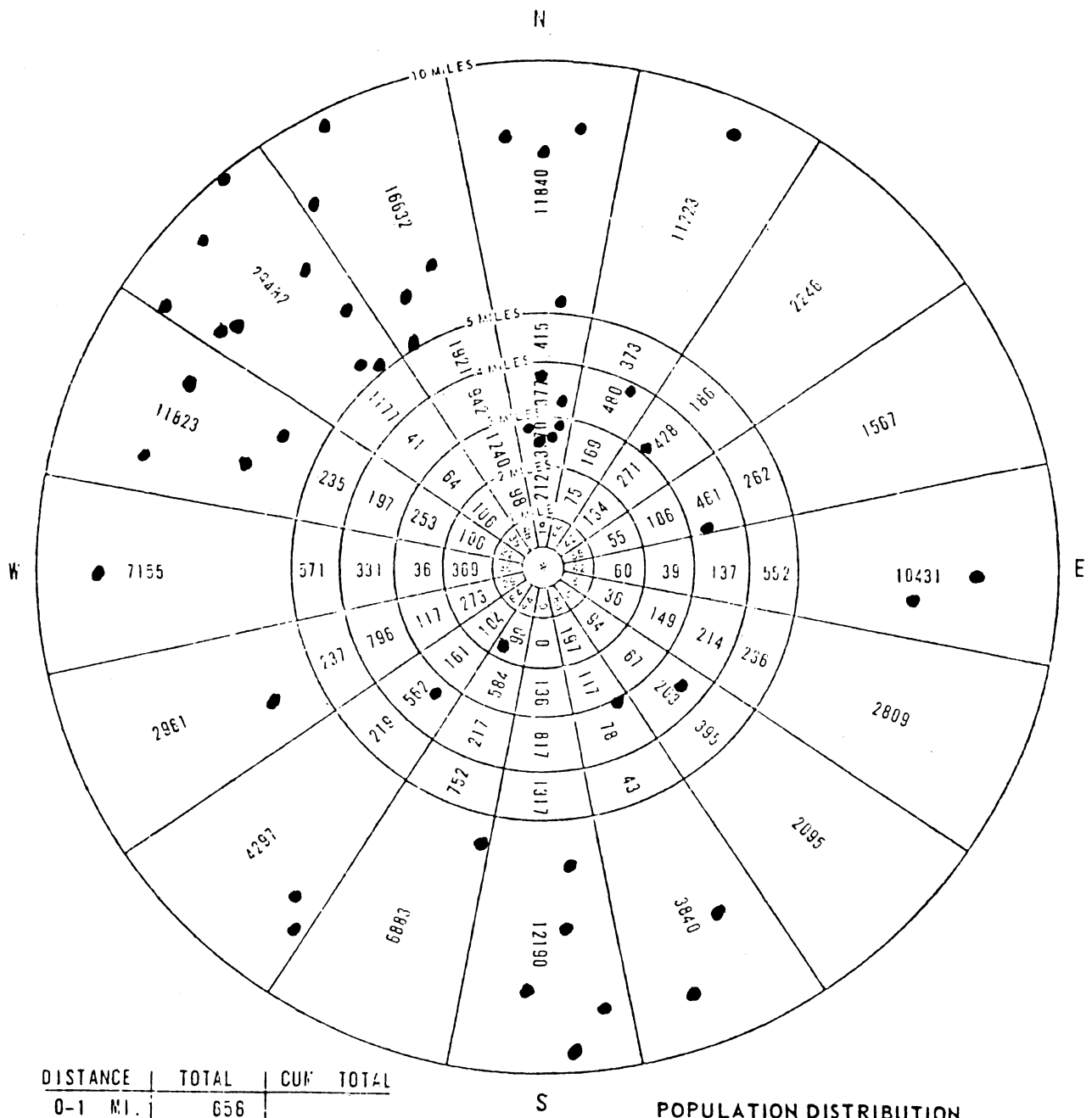

DISTANCE	TOTAL	CUM TOTAL
0-1 MI.	656	
1-2 MI.	2,017	2,675
2-3 MI.	7,579	10,254
3-4 MI.	9,676	19,930
4-5 MI.	8,891	28,821
5-10 MI.	137,474	166,295

" EXCLUSION RADIUS

POPULATION DISTRIBUTION
0 TO 10 MILES - 1980
THREE MILE ISLAND NUCLEAR STATION UNIT 2



FIG. F-1. RANDOMLY SELECTED LISTENER SITES AT THREE MILE ISLAND.

**APPENDIX G: TEST CASES (SAMPLE SCENARIOS) FOR THE
THREE MILE ISLAND SITE**

1. Warm Summer Weekday Afternoon: Weather clear to partly cloudy.

People: 30% indoors, at work
40% indoors, at home
20% outdoors
6% in motor vehicles (windows open)
4% asleep

Buildings: Windows open (homes)
Windows closed (workplace)

Wind: (100 ft) 5 mph from East

Temperature Gradient: -1.0° F/100 ft.,
Pasquill stability Class A

Relative Humidity: 65%

2. Summer Weekday Night: Weather clear to partly cloudy.

People: 95% indoors, sleeping
4% indoors, at work
1% in motor vehicles (windows closed)

Buildings: Windows open (homes)
Windows closed (workplace)

Wind (100 ft): Northwest, 5 mph

Temperature Gradient: $+0.5^{\circ}$ F/100 ft.
Stability Class E

Relative Humidity: 80%

3. Winter Weekday During Evening Community Hours: Cold, overcast

People: 70% indoors
25% in motor vehicles (windows closed)
5% outdoors

Buildings: Windows closed, storm windows closed

3. Continued

Wind (100 ft): Southeast at 3 mph

Temperature Gradient: $-0.5^{\circ}\text{F}/100\text{ ft.}$
Stability Class D

Relative Humidity: 70%

4. Winter Night During Snowfall.

People: 95% indoors, sleeping
5% indoors, at work

Building: Windows closed, storm windows closed

Wind (100 ft.): West at 15 mph

Temperature Gradient: $-0.5^{\circ}\text{F}/100\text{ ft}$
Stability Class D

Relative Humidity: 90%

APPENDIX H: SIREN LOCATIONS FOR THE TMI EPZ

This appendix provides siren information for the TMI EPZ. Siren locations are indicated on Fig. H-1 (see foldout). Table H.1 provides information on the type and rating for each siren.

TABLE H.1. TMI SIREN INFORMATION.

County/Siren Designation	Type*	Rated SPL (dB @ 100 ft)
Cumberland C1	R	124
Cumberland C2	S	122
Cumberland C3	S	122
Dauphin D1	S	122
Dauphin D2	S	122
Dauphin D3	R	124
Dauphin D4	S	122
Dauphin D5	S	122
Dauphin D6	S	122
Dauphin D7	S	122
Dauphin D8	R	124
Dauphin D9	S	122
Dauphin D10	S	122
Dauphin D11	S	122
Dauphin D12	S	122
Dauphin D13	S	122
Dauphin D14	S	122
Dauphin D15	S	122
Dauphin D16	R	124
Dauphin D17	R	124
Dauphin D18	S	122
Dauphin D19	S	122
Dauphin D20	S	122

*Rotating (R) or Stationary (S)

TABLE H.1. TMI SIREN INFORMATION (Cont.)

County/Siren Designation	Type*	Rated SPL (dB @ 100 ft)
Dauphin D22	E	124
Dauphin D23	S	122
Dauphin D24	R	124
Dauphin D25	R	124
Dauphin D26	R	124
Dauphin D27	R	124
Dauphin D28	S	122
Dauphin D29	R	124
Dauphin D30	S	122
Lancaster LA1	R	124
Lancaster LA2	R	124
Lancaster LA3	R	124
Lancaster LA4	R	124
Lancaster LA5	R	124
Lancaster LA6	R	124
Lancaster LA7	S	122
Lancaster LA8	S	122
Lancaster LA9	R	124
Lancaster LA10	S	122
Lancaster LA11	R	124
Lancaster LA12	S	122
Lancaster LA13	R	124
Lancaster LA14	S	122
Lebanon LE1	S	122
Lebanon LE2	S	122
York Y1	S	122
York Y2	R	124

*Rotating (R) or Stationary (S)

TABLE H.1. TMI SIREN INFORMATION (Cont.)

County/Siren Designation	Type*	Rated SPL (dB @ 100 ft)
York Y3	S	122
York Y4	S	122
York Y5	S	122
York Y6	R	124
York Y7	S	122
York Y8	R	124
York Y9	S	122
York Y10	S	122
York Y11	R	124
York Y12	R	124
York Y13	S	122
York Y14	S	122
York Y15	R	124
York Y16	S	122
York Y17	S	122
York Y18	S	122
York Y19	S	122
York Y20	S	122
York Y21	R	124
York Y22	S	122
York Y23	S	122
York Y24	R	124
York Y25	S	122
York Y26	S	122
York Y27	R	124
York Y28	S	122
York Y29	S	122
York Y30	R	124

*Rotating (R) or Stationary (S)

TABLE H.1. TMI SIREN INFORMATION (Cont.)

County/Siren Designation	Type*	Rated SPL (dB @ 100 ft)
York Y31	R	124
York Y32	S	122
York Y33	S	122

*Rotating (R) or Stationary (S)

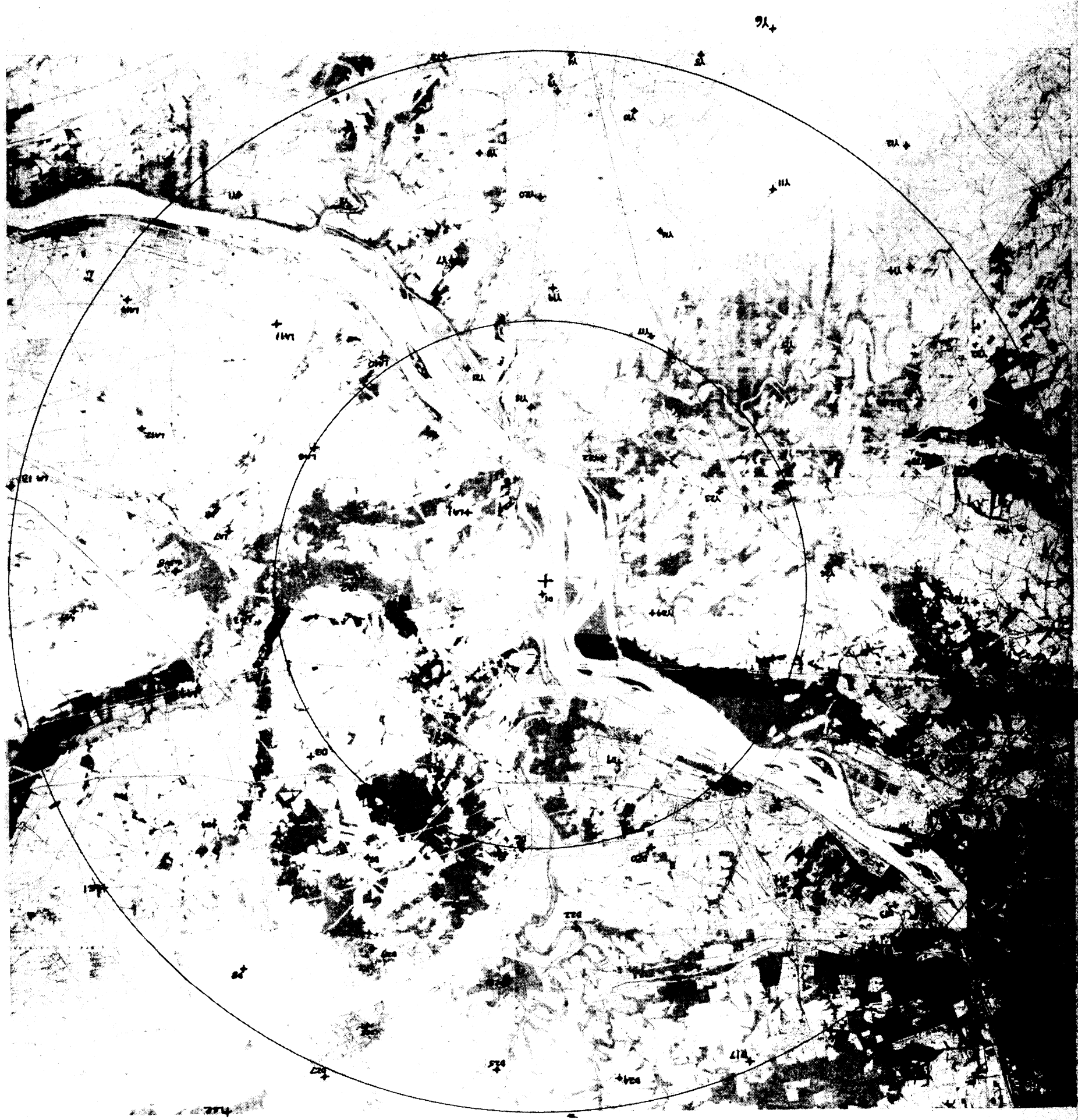

FIG. H-1. TMI SIREN LOCATION MAP.

H-5

APPENDIX I: ANALYSIS INPUT/OUTPUT DATA FOR THREE MILE ISLAND

This appendix provides listings of computer file input and output data for the TMI analysis. Explanation of the terminology used for each listing is provided below.

TABLE I.1. TMI-SIRENS

This file contains input data for each of the TMI sirens as follows:

- Siren No. number assigned to each siren for use by computer program
- Siren Name first letter indicates whether the siren is rotating or stationary type (R or S); the remainder consists of the actual TMI siren designation, beginning with county letter abbreviation and ending with a number.
- x, y, z these are the physical coordinates for the siren location; the x-axis is oriented east-west, the y-axis is oriented north-south, and the z-axis is oriented vertically. The x and y coordinates are in units of km, referenced to the grid shown on the Feb. 1981 NRC Emergency Planning Map for TMI (the plant center is located approximately at x = 353, y = 4446). The z coordinates are in units of feet.
- SPL@100FT these numbers indicate the rated sound pressure level for each siren at a distance of 100 ft, in dB.

TABLE I.2. TMI-LISTENERS

This file contains input data for each of the randomly selected listener locations as follows:

- Site No. number assigned to each site for use by computer program
- Site Name designator for listener site; the first letter indicates whether site is urban or rural (U or R).
- x, y, z these are the physical coordinates for the siren location; the x-axis is oriented east-west, the y-axis is oriented north-south, and the z-axis is oriented vertically. The x and y coordinates are in units of km, referenced to the grid shown on the Feb. 1981 NRC Emergency Planning Map for TMI (the plant center is located approximately at x = 353, y = 4446). The z coordinates are in units of feet.
- ODLR the outdoor median alerting level for a 4-min. rotating siren (see Table 3.4 and Fig. 3-3 of text). An entry is given for each of the four scenarios.
- OVCR the outdoor alert distribution for a 4-min. rotating siren (see Table 3.4 and Fig. 3-3 of text). An entry is given for each of the four scenarios.
- OVLS the outdoor median alerting level for a 4-min. stationary siren (see Table 3.4 and Fig. 3-3 of text). An entry is given for each of the four scenarios.

- OVCS The outdoor alert distribution for a 4-min. stationary siren (see Table 3.4 and Fig. 3-3 of text). An entry is given for each of the four scenarios.

TABLE I.3. TMI-SCENARIO

This file contains input for each of the four sample scenarios as follows:

- Scenario No. number assigned to each scenario (see App. G.)
- AMCL molecular absorption, in dB/1000 ft
- WIND wind direction in degrees (0° = wind from north, etc.)
- NRES residential building outdoor-to-indoor noise reduction, in dB
- NCRM commercial building outdoor-to-indoor noise reduction, in dB
- F1 - F10 activity fractions
 - F1 fraction of people outdoors
 - F2 fraction of people indoors, at home, listening to radio or TV
 - F3 fraction of people indoors, at home, sleeping
 - F4 fraction of people indoors, at home, neither sleeping nor listening to radio or TV
 - F5 fraction of people indoors, at work, in commercial establishments
 - F6 fraction of people indoors, at work, in industrial locations

F7	fraction of people in vehicles in rural areas at 55 mph
F8	fraction of people in vehicles in rural areas at 30 mph
F9	fraction of people in vehicles in urban areas at 55 mph
F10	fraction of people in vehicles in urban areas at 30 mph
• INP	indoor alert probability curve (see Figs. 3-4 and 3-5 of text)
• PU55	probability of alert for motorists in urban areas at 55 mph
• PU30	probability of alert for motorists in urban areas at 30 mph
• PR55	probability of alert for motorists in rural areas at 55 mph
• PR30	probability of alert for motorists in rural areas at 30 mph
• MUL	vertical profile of wind speed, βz , in ft/sec/ln ft.
• ADD	vertical profile of air temperature, a , in °F/ln ft.

TABLE I.4. LISTENEROUTPUT

This listing provides the number, name, and outdoor sound pressure level (LOUT, in dB) for the "dominant" siren at each sample listener location, for each of the four sample scenarios. The results are listed in numerical order for scenarios one through four for each listener site.

TABLE I.5. PROBS

This listing provides the final results for the analysis. Information is listed in numerical order for scenarios one through four for each listener site. This information consists of alert probabilities P1 through P10 corresponding to activity fractions F1 through F10, as well as the total probability of alert (PT) for each sample scenario at each sample listener site.

A summary is provided at the end of the listing showing the rural and urban populations followed by the total rural probability of alert (PTRUR), the total urban probability of alert for the EPZ (PTALL). The total probability values are listed in numerical order for sample scenarios one through four.

TABLE I.1.

<u>IMI-SIRENS</u>					
SIREN#	SIREN NAME	X	Y	Z	SPL@100 FT
1	R C1	341.650	4454.200	360.000	124
2	S C2	338.950	4455.600	450.000	122
3	S C3	340.550	4452.950	450.000	122
4	S D1	353.200	4446.600	350.000	122
5	S D2	355.950	4450.150	590.000	122
6	R D3	360.300	4451.300	510.000	124
7	S D4	363.300	4453.250	520.000	122
8	S D5	352.500	4450.500	370.000	122
9	S D6	354.000	4454.250	470.000	122
10	S D7	358.700	4454.400	640.000	122
11	R D8	362.550	4457.700	480.000	124
12	S D9	351.000	4451.650	390.000	122
13	S D10	347.700	4452.250	360.000	122
14	S D11	346.150	4452.900	390.000	122
15	S D12	344.200	4455.550	550.000	122
16	S D13	342.750	4456.200	430.000	122
17	S D14	344.150	4457.800	425.000	122
18	S D15	342.400	4459.300	600.000	122
19	R D16	344.750	4460.050	550.000	124
20	R D17	346.900	4460.550	540.000	124
21	S D18	346.600	4458.150	470.000	122
22	S D19	346.100	4455.450	570.000	122
23	S D20	350.100	4454.300	490.000	122
24	R D22	352.350	4456.650	350.000	124
25	S D23	354.600	4458.350	450.000	122
26	R D24	351.150	4461.300	530.000	124
27	R D25	354.900	4461.000	510.000	124
28	R D26	357.700	4464.650	450.000	124
29	S D27	360.100	4461.100	430.000	122
30	S D28	358.750	4459.600	450.000	122
31	R D29	358.600	4457.250	750.000	124
32	S D30	349.200	4458.450	530.000	122
33	R LA1	355.500	4443.950	570.000	124
34	R LA2	358.650	4446.000	570.000	124
35	R LA3	362.300	4446.950	590.000	124
36	R LA4	363.650	4449.250	490.000	124
37	R LA5	367.550	4450.750	530.000	124
38	R LA6	360.000	4441.800	510.000	124
39	S LA7	362.700	4444.350	460.000	122
40	S LA8	364.300	4445.650	530.000	122
41	R LA9	367.400	4446.800	590.000	124
42	S LA10	357.900	4439.050	350.000	122
43	R LA11	361.100	4438.000	450.000	124
44	S LA12	365.250	4441.150	450.000	122
45	R LA13	369.400	4442.850	450.000	124
46	S LA14	365.700	4437.200	450.000	122
47	S LE1	366.700	4455.100	560.000	122
48	S LE2	363.150	4462.050	500.000	122
49	S Y1	362.250	4434.150	730.000	122
50	R Y2	358.800	4434.550	370.000	124

TABLE I.1. (Cont.)

51	S	Y3	355.900	4430.100	550.000	122
52	S	Y4	352.050	4430.100	470.000	122
53	S	Y5	348.100	4430.250	530.000	122
54	R	Y6	346.000	4429.600	490.000	124
55	S	Y7	355.800	4436.250	520.000	122
56	R	Y8	354.950	4433.000	690.000	124
57	S	Y9	352.450	4431.250	460.000	122
58	S	Y10	350.150	4431.850	490.000	122
59	R	Y11	346.000	4434.300	530.000	124
60	R	Y12	341.950	4433.050	670.000	124
61	S	Y13	337.850	4434.700	570.000	122
62	S	Y14	341.850	4436.700	600.000	122
63	R	Y15	345.600	4439.200	630.000	124
64	S	Y16	349.450	4435.500	390.000	122
65	S	Y17	349.750	4438.600	470.000	122
66	S	Y18	353.450	4440.700	510.000	122
67	S	Y19	352.800	4437.100	500.000	122
68	S	Y20	353.100	4434.400	530.000	122
69	R	Y21	355.350	4439.500	330.000	124
70	S	Y22	351.300	4442.250	520.000	122
71	S	Y23	347.750	4443.500	670.000	122
72	R	Y24	349.900	4447.200	490.000	124
73	S	Y25	347.000	4449.350	770.000	122
74	S	Y26	344.600	4445.850	510.000	122
75	R	Y27	344.100	4451.150	370.000	124
76	S	Y28	342.000	4450.350	920.000	122
77	S	Y29	338.750	4451.950	570.000	122
78	R	Y30	340.100	4447.000	620.000	124
79	R	Y31	338.650	4444.750	540.000	124
80	S	Y32	339.500	4439.550	675.000	122
81	S	Y33	342.050	4442.700	530.000	122

TABLE I.2.

TMI-LISTENERS

<u>SITE #</u>	<u>SITE NAME</u>	<u>X</u>	<u>i</u>	<u>X</u>	<u>UDLR</u>	<u>UVCR</u>	<u>UDLS</u>	<u>UVCS</u>
1	R 1	351.700	4443.420	290.000	51.0	6.0	50.0	4.0
					51.0	6.0	50.0	4.0
					51.0	6.0	50.0	4.0
					51.0	6.0	50.0	4.0
2	U 2	352.600	4450.700	325.000	54.0	5.0	52.0	3.0
					43.0	3.0	43.0	2.0
					49.0	4.0	48.0	3.0
					43.0	3.0	43.0	2.0
3	U 3	353.000	4450.450	315.000	50.0	5.0	48.0	4.0
					42.0	3.0	41.0	2.0
					48.0	4.0	47.0	3.0
					42.0	3.0	41.0	2.0
4	U 4	353.200	4450.550	315.000	50.0	5.0	48.0	4.0
					42.0	3.0	41.0	2.0
					48.0	4.0	47.0	3.0
					42.0	3.0	41.0	2.0
5	U 5	353.400	4450.700	335.000	50.0	5.0	48.0	4.0
					42.0	3.0	41.0	2.0
					48.0	4.0	47.0	3.0
					42.0	3.0	41.0	2.0
6	U 6	353.100	4452.150	300.000	63.0	6.0	61.0	4.0
					63.0	6.0	61.0	4.0
					63.0	6.0	61.0	4.0
					63.0	6.0	61.0	4.0
7	U 7	353.650	4451.200	300.000	54.0	5.0	52.0	3.0
					43.0	3.0	43.0	2.0
					49.0	4.0	48.0	3.0
					43.0	3.0	43.0	2.0
8	R 8	355.750	4451.700	425.000	63.0	6.0	61.0	4.0
					63.0	6.0	61.0	4.0
					63.0	6.0	61.0	4.0
					63.0	6.0	61.0	4.0
9	R 9	356.300	4449.700	525.000	51.0	6.0	50.0	4.0
					51.0	6.0	50.0	4.0
					51.0	6.0	50.0	4.0
					51.0	6.0	50.0	4.0
10	R 10	356.300	4447.100	385.000	51.0	6.0	50.0	4.0
					51.0	6.0	50.0	4.0
					51.0	6.0	50.0	4.0
					51.0	6.0	50.0	4.0

TABLE I.2. (Cont.)

11	R 11	357.700	4442.500	385.000	39.0	5.0	38.0	3.0
					39.0	5.0	38.0	3.0
					36.0	5.0	35.0	3.0
					47.0	5.0	46.0	3.0
12	R 12	355.650	4441.850	385.000	51.0	6.0	50.0	4.0
					51.0	6.0	50.0	4.0
					51.0	6.0	50.0	4.0
					51.0	6.0	50.0	4.0
13	R 13	349.650	4442.200	485.000	39.0	5.0	38.0	3.0
					39.0	5.0	38.0	3.0
					36.0	5.0	35.0	3.0
					47.0	5.0	46.0	3.0
14	R 14	353.430	4434.300	350.000	50.0	6.0	54.0	4.0
					50.0	6.0	54.0	4.0
					56.0	6.0	54.0	4.0
					56.0	6.0	54.0	4.0
15	R 15	352.150	4460.000	500.000	39.0	5.0	38.0	3.0
					39.0	5.0	38.0	3.0
					36.0	5.0	35.0	3.0
					47.0	5.0	46.0	3.0
16	R 16	352.800	4459.750	465.000	39.0	5.0	38.0	3.0
					39.0	5.0	38.0	3.0
					36.0	5.0	35.0	3.0
					47.0	5.0	46.0	3.0
17	R 17	353.600	4460.150	425.000	39.0	5.0	38.0	3.0
					39.0	5.0	38.0	3.0
					36.0	5.0	35.0	3.0
					47.0	5.0	46.0	3.0
18	U 18	359.450	4460.200	440.000	50.0	5.0	48.0	4.0
					42.0	3.0	41.0	2.0
					48.0	4.0	47.0	3.0
					42.0	3.0	41.0	2.0
19	U 19	364.350	4444.750	485.000	50.0	5.0	48.0	4.0
					42.0	3.0	41.0	2.0
					48.0	4.0	47.0	3.0
					42.0	3.0	41.0	2.0
20	R 20	366.300	4444.900	490.000	39.0	5.0	38.0	3.0
					39.0	5.0	38.0	3.0
					36.0	5.0	35.0	3.0
					47.0	5.0	46.0	3.0

TABLE I.2. (Cont.)

21	R 21	358.750	4435.200	490.000	51.0	6.0	50.0	4.0
					51.0	6.0	50.0	4.0
					51.0	6.0	50.0	4.0
					51.0	6.0	50.0	4.0
22	R 22	357.850	4432.400	350.000	39.0	5.0	38.0	3.0
					39.0	5.0	38.0	3.0
					36.0	5.0	35.0	3.0
					47.0	5.0	46.0	3.0
23	R 23	354.950	4437.200	480.000	51.0	6.0	50.0	4.0
					51.0	6.0	50.0	4.0
					51.0	6.0	50.0	4.0
					51.0	6.0	50.0	4.0
24	U 24	354.100	4435.650	410.000	50.0	5.0	48.0	4.0
					42.0	3.0	41.0	2.0
					48.0	4.0	47.0	3.0
					42.0	3.0	41.0	2.0
25	R 25	352.800	4433.250	400.000	51.0	6.0	50.0	4.0
					51.0	6.0	50.0	4.0
					51.0	6.0	50.0	4.0
					51.0	6.0	50.0	4.0
26	R 26	355.300	4432.850	560.000	51.0	6.0	50.0	4.0
					51.0	6.0	50.0	4.0
					51.0	6.0	50.0	4.0
					51.0	6.0	50.0	4.0
27	R 27	354.800	4434.800	360.000	51.0	6.0	50.0	4.0
					51.0	6.0	50.0	4.0
					51.0	6.0	50.0	4.0
					51.0	6.0	50.0	4.0
28	R 28	351.300	4437.500	330.000	48.0	6.0	47.0	4.0
					48.0	6.0	47.0	4.0
					48.0	6.0	47.0	4.0
					48.0	6.0	47.0	4.0
29	R 29	345.100	4435.300	675.000	39.0	5.0	38.0	3.0
					39.0	5.0	38.0	3.0
					36.0	5.0	35.0	3.0
					47.0	5.0	46.0	3.0
30	R 30	345.150	4434.550	470.000	39.0	5.0	38.0	3.0
					39.0	5.0	38.0	3.0
					36.0	5.0	35.0	3.0
					47.0	5.0	46.0	3.0

TABLE I.2. (Cont.)

31	R	31	344.700	4442.250	465.000	51.0	6.0	50.0	4.0
						51.0	6.0	50.0	4.0
						51.0	6.0	50.0	4.0
						51.0	6.0	50.0	4.0
32	R	32	338.500	4440.000	525.000	39.0	5.0	38.0	3.0
						39.0	5.0	38.0	3.0
						36.0	5.0	35.0	3.0
						47.0	5.0	46.0	3.0
33	R	33	343.550	4449.500	600.000	61.0	6.0	59.0	4.0
						61.0	6.0	59.0	4.0
						61.0	6.0	59.0	4.0
						61.0	6.0	59.0	4.0
34	R	34	344.000	4452.200	625.000	39.0	5.0	38.0	3.0
						39.0	5.0	38.0	3.0
						36.0	5.0	35.0	3.0
						47.0	5.0	46.0	3.0
35	R	35	339.350	4449.000	605.000	51.0	6.0	50.0	4.0
						51.0	6.0	50.0	4.0
						51.0	6.0	50.0	4.0
						51.0	6.0	50.0	4.0
36	R	36	342.750	4452.150	400.000	59.0	6.0	57.0	4.0
						59.0	6.0	57.0	4.0
						59.0	6.0	57.0	4.0
						59.0	6.0	57.0	4.0
37	U	37	341.900	4453.950	325.000	54.0	5.0	52.0	3.0
						43.0	3.0	43.0	2.0
						49.0	4.0	48.0	3.0
						43.0	3.0	43.0	2.0
38	U	38	342.100	4454.250	315.000	54.0	5.0	52.0	3.0
						43.0	3.0	43.0	2.0
						49.0	4.0	48.0	3.0
						43.0	3.0	43.0	2.0
39	U	39	340.550	4454.550	370.000	50.0	5.0	48.0	4.0
						42.0	3.0	41.0	2.0
						48.0	4.0	47.0	3.0
						42.0	3.0	41.0	2.0
40	U	40	347.500	4452.520	330.000	50.0	5.0	48.0	4.0
						42.0	3.0	41.0	2.0
						48.0	4.0	47.0	3.0
						42.0	3.0	41.0	2.0

TABLE I.2. (Cont.)

41	U	41	348.100	4452.550	365.000	54.0	5.0	52.0	3.0
						43.0	3.0	43.0	2.0
						49.0	4.0	48.0	3.0
						43.0	3.0	43.0	2.0
42	R	42	346.600	4454.950	465.000	51.0	6.0	50.0	4.0
						51.0	6.0	50.0	4.0
						51.0	6.0	50.0	4.0
						51.0	6.0	50.0	4.0
43	U	43	345.300	4455.800	505.000	50.0	5.0	48.0	4.0
						42.0	3.0	41.0	2.0
						48.0	4.0	47.0	3.0
						42.0	3.0	41.0	2.0
44	U	44	342.000	4456.700	365.000	50.0	5.0	48.0	4.0
						42.0	3.0	41.0	2.0
						48.0	4.0	47.0	3.0
						42.0	3.0	41.0	2.0
45	U	45	343.200	4458.800	480.000	50.0	5.0	48.0	4.0
						42.0	3.0	41.0	2.0
						48.0	4.0	47.0	3.0
						42.0	3.0	41.0	2.0
46	R	46	348.800	4452.950	420.000	63.0	6.0	61.0	4.0
						63.0	6.0	61.0	4.0
						63.0	6.0	61.0	4.0
						63.0	6.0	61.0	4.0
47	R	47	348.200	4454.400	485.000	51.0	6.0	50.0	4.0
						51.0	6.0	50.0	4.0
						51.0	6.0	50.0	4.0
						51.0	6.0	50.0	4.0
48	R	48	349.550	4455.800	565.000	51.0	6.0	50.0	4.0
						51.0	6.0	50.0	4.0
						51.0	6.0	50.0	4.0
						51.0	6.0	50.0	4.0
49	U	49	345.350	4457.900	380.000	50.0	5.0	48.0	4.0
						42.0	3.0	41.0	2.0
						48.0	4.0	47.0	3.0
						42.0	3.0	41.0	2.0
50	U	50	345.900	4460.350	525.000	50.0	5.0	48.0	4.0
						42.0	3.0	41.0	2.0
						48.0	4.0	47.0	3.0
						42.0	3.0	41.0	2.0

TABLE I.3.

TMI-SCENARIO

SCEN#	AMUL	WIND	NRCS	NCRM	r1	r2	r3	r4	r5	r6	r7	r8	r9	r10
1	0.88	90	10.	31.	.220	.200	.040	.200	.230	.070	.020	.000	.000	.040
2	0.79	315	10.	31.	.000	.000	.950	.000	.030	.010	.023	.000	.000	.007
3	0.55	135	31.	31.	.000	.140	.000	.000	.000	.000	.070	.000	.000	.100
4	0.64	270	31.	31.	.000	.000	.950	.000	.040	.010	.000	.000	.000	.000

INP	POSS	PO30	PR30	PR30	MUL	ADD
1	1.000	1.000	1.000	1.000	1.070	0.910
1	1.000	1.000	1.000	1.000	1.070	-0.400
3	1.000	1.000	1.000	1.000	1.120	0.400
1	1.000	1.000	1.000	1.000	0.600	0.400

TABLE I.4. LISTENER OUTPUT

lis #	listener name	siren #	siren name	out
1	R 1	33	R LA1	70.9
		4	S D1	71.6
		70	S Y22	69.7
		70	S Y22	69.3
2	U 2	8	S D5	104.0
		8	S D5	104.1
		8	S D5	104.3
		8	S D5	104.2
3	U 3	8	S D5	81.2
		8	S D5	90.3
		8	S D5	86.7
		8	S D5	96.6
4	U 4	8	S D5	72.7
		8	S D5	92.9
		8	S D5	83.5
		8	S D5	93.3
5	U 5	5	S D2	75.8
		8	S D5	90.0
		5	S D2	78.6
		8	S D5	90.4
6	U 6	5	S D2	70.8
		9	S D6	78.6
		8	S D5	83.6
		8	S D5	83.1
7	U 7	5	S D2	72.5
		8	S D5	84.1
		5	S D2	75.0
		8	S D5	84.0
8	R 8	5	S D2	63.3
		8	S D5	71.9
		5	S D2	65.0
		8	S D5	73.6
9	R 9	5	S D2	79.9
		5	S D2	95.1
		5	S D2	85.5
		5	S D2	95.4
10	R 10	34	R LA2	79.1
		34	R LA2	69.4
		34	R LA2	90.3
		34	R LA2	70.0

TABLE I.4. (Cont.)

11	R 11	38	R LA0	65.7
		33	R LA1	69.8
		38	R LA0	68.3
		33	R LA1	70.3
12	R 12	60	S Y18	50.0
		66	S Y18	77.3
		69	R Y21	81.9
		60	S Y18	78.0
13	R 13	72	S Y22	82.0
		70	S Y22	83.2
		70	S Y22	84.3
		70	S Y22	83.9
14	R 14	9	S D6	94.3
		9	S D6	84.5
		9	S D6	95.8
		9	S D6	74.8
15	R 15	27	R D25	70.9
		20	R D24	80.3
		27	R D25	74.1
		20	R D24	81.1
16	R 16	25	S D23	77.9
		27	R D25	79.6
		25	S D23	80.4
		20	R D24	74.5
17	R 17	25	S D23	79.5
		27	R D25	75.9
		25	S D23	81.7
		20	R D24	71.8
18	U 18	29	S D27	87.0
		30	S D28	90.8
		32	S D28	82.7
		33	S D23	90.4
19	U 19	40	S LA8	75.0
		40	S LA8	90.2
		40	S LA8	70.0
		40	S LA8	90.7
20	R 20	41	R LA9	68.2
		40	S LA8	64.0
		44	S LA12	61.4
		40	S LA8	65.7

TABLE I.4. (Cont.)

21	R 21	58	R Y2	85.5
		58	R Y2	85.7
		58	R Y2	90.2
		58	R Y2	86.8
22	R 22	59	R Y2	51.1
		59	R Y2	80.8
		58	R Y2	48.0
		51	S Y3	54.3
23	R 23	55	S Y7	72.5
		67	S Y19	80.5
		68	S Y20	77.6
		67	S Y19	87.1
24	U 24	55	S Y7	68.2
		67	S Y19	82.8
		55	S Y7	78.1
		67	S Y19	81.8
25	R 25	68	S Y20	71.7
		68	S Y20	87.1
		57	S Y9	81.9
		57	S Y9	81.3
26	R 26	50	R Y8	70.4
		50	R Y8	80.5
		51	S Y3	77.0
		50	R Y8	80.7
27	R 27	51	S Y3	85.0
		57	S Y9	77.9
		51	S Y3	87.8
		57	S Y9	79.1
28	R 28	67	S Y19	81.3
		65	S Y17	68.8
		67	S Y19	83.8
		65	S Y17	68.9
29	R 29	59	R Y11	87.2
		59	R Y11	67.0
		59	R Y11	88.7
		59	R Y11	68.3
		59	R Y11	68.3
30	R 30	59	R Y11	80.2
		59	R Y11	71.5
		59	R Y11	87.2
		59	R Y11	60.9

TABLE I.4. (Cont.)

31	R 31	71	S Y23	56.8
		81	S Y33	61.5
		71	S Y23	55.4
		81	S Y33	62.8
32	R 32	78	R Y32	82.7
		78	R Y32	83.3
		79	R Y31	77.4
		78	R Y32	84.2
33	R 33	73	S Y25	65.9
		78	S Y28	82.1
		74	S Y28	73.2
		78	S Y28	83.8
34	R 34	75	R Y27	84.7
		75	R Y27	85.1
		75	R Y27	85.9
		75	R Y27	85.6
35	R 35	76	S Y28	51.2
		77	S Y29	65.7
		78	S Y28	54.1
		77	S Y29	68.8
36	R 36	3	S C3	78.8
		3	S C3	91.2
		3	S C3	78.9
		3	S C3	91.8
37	U 37	1	R C1	98.7
		1	R C1	101.8
		1	R C1	97.1
		1	R C1	102.8
38	U 38	1	R C1	83.8
		1	R C1	98.9
		1	R C1	89.3
		1	R C1	99.2
39	U 39	1	R C1	89.1
		2	S C2	78.2
		1	R C1	98.4
		2	S C2	79.1
40	U 40	13	S D18	100.8
		13	S D18	100.7
		13	S D18	101.8
		13	S D18	98.9

TABLE I.4. (Cont.)

41	U 41	13	S D10	81.3
		13	S D10	96.4
		13	S D10	91.3
		13	S D10	90.7
42	R 42	22	S D19	77.0
		22	S D19	92.8
		22	S D19	78.4
		22	S D19	93.2
43	U 43	22	S D19	90.3
		15	S D12	87.7
		22	S D19	91.3
		15	S D12	88.3
44	U 44	10	S D13	90.8
		10	S D13	75.2
		10	S D13	91.8
		2	S C2	74.7
45	U 45	17	S D14	84.0
		18	S D15	90.9
		17	S D14	86.1
		18	S D15	93.5
46	R 46	23	S D20	81.1
		23	S D20	81.0
		12	S D9	76.8
		13	S D10	82.2
47	R 47	23	S D22	83.9
		14	S D11	72.8
		23	S D20	83.0
		13	S D10	76.3
48	R 48	23	S D20	90.1
		23	S D20	75.4
		23	S D20	91.1
		13	S D10	74.3
49	U 49	21	S D10	85.9
		17	S D14	86.9
		21	S D10	87.3
		17	S D14	87.5
50	U 50	20	R D17	90.0
		19	R D10	89.1
		20	R D17	91.7
		19	R D10	89.7

TABLE I.5. PROBS

	p1	p2	p3	p4	p5	p6	p7	p8	p9	p10	pt
listener 1											
	1.000	1.000	0.520	0.901	0.395	1.000	1.000	1.000	1.000	1.000	0.8219
	1.000	1.000	0.610	0.957	0.572	1.000	1.000	1.000	1.000	1.000	0.6221
	1.000	1.000	0.351	0.272	0.405	1.000	1.000	1.000	1.000	1.000	0.5922
	1.000	1.000	0.345	0.054	0.374	1.000	1.000	1.000	1.000	1.000	0.3527
listener 2											
	1.000	1.000	0.931	1.000	1.000	1.000	1.000	1.000	1.000	1.000	0.9972
	1.000	1.000	0.931	1.000	1.000	1.000	1.000	1.000	1.000	1.000	0.9346
	1.000	1.000	0.819	1.000	1.000	1.000	1.000	1.000	1.000	1.000	1.0000
	1.000	1.000	0.819	1.000	1.000	1.000	1.000	1.000	1.000	1.000	0.8276
listener 3											
	1.000	1.000	0.730	1.000	1.000	1.000	1.000	1.000	1.000	1.000	0.9654
	1.000	1.000	0.880	1.000	1.000	1.000	1.000	1.000	1.000	1.000	0.8855
	1.000	1.000	0.610	0.874	1.000	1.000	1.000	1.000	1.000	1.000	0.9296
	1.000	1.000	0.740	1.000	1.000	1.000	1.000	1.000	1.000	1.000	0.7535
listener 4											
	1.000	1.000	0.632	0.965	0.073	1.000	1.000	1.000	1.000	1.000	0.9236
	1.000	1.000	0.852	1.000	1.000	1.000	1.000	1.000	1.000	1.000	0.8594
	1.000	1.000	0.573	0.791	1.000	1.000	1.000	1.000	1.000	1.000	0.8632
	1.000	1.000	0.722	0.950	1.000	1.000	1.000	1.000	1.000	1.000	0.7169
listener 5											
	1.000	1.000	0.672	0.980	0.675	1.000	1.000	1.000	1.000	1.000	0.9539
	1.000	1.000	0.826	1.000	1.000	1.000	1.000	1.000	1.000	1.000	0.8346
	1.000	1.000	0.500	0.623	0.975	1.000	1.000	1.000	1.000	1.000	0.7687
	1.000	1.000	0.667	0.576	1.000	1.000	1.000	1.000	1.000	1.000	0.6637
listener 6											
	1.000	1.000	0.605	0.952	0.503	1.000	1.000	1.000	1.000	1.000	0.8603
	1.000	1.000	0.786	0.996	0.971	1.000	1.000	1.000	1.000	1.000	0.7194
	1.000	1.000	0.575	0.795	1.000	1.000	1.000	1.000	1.000	1.000	0.8654
	1.000	1.000	0.567	0.927	1.000	1.000	1.000	1.000	1.000	1.000	0.5689
listener 7											
	1.000	1.000	0.628	0.963	0.652	1.000	1.000	1.000	1.000	1.000	0.8576
	1.000	1.000	0.766	1.000	1.000	1.000	1.000	1.000	1.000	1.000	0.7754
	1.000	1.000	0.442	0.476	0.834	1.000	1.000	1.000	1.000	1.000	0.7007
	1.000	1.000	0.592	0.944	1.000	1.000	1.000	1.000	1.000	1.000	0.6125
listener 8											
	0.881	1.000	0.495	0.861	0.320	1.000	1.000	1.000	1.000	1.000	0.6981
	1.000	1.000	0.621	0.900	0.664	1.000	1.000	1.000	1.000	1.000	0.6276
	1.000	1.000	0.594	0.833	1.000	1.000	1.000	1.000	1.000	1.000	0.9063
	1.000	1.000	0.419	0.765	0.742	1.000	1.000	1.000	1.000	1.000	0.4377
listener 9											
	1.000	1.000	0.721	1.000	0.999	1.000	1.000	1.000	1.000	1.000	0.9867
	1.000	1.000	0.870	1.000	1.000	1.000	1.000	1.000	1.000	1.000	0.8761
	1.000	1.000	0.602	0.546	1.000	1.000	1.000	1.000	1.000	1.000	0.9140
	1.000	1.000	0.726	1.000	1.000	1.000	1.000	1.000	1.000	1.000	0.7401
listener 10											
	1.000	1.000	0.636	0.975	0.803	1.000	1.000	1.000	1.000	1.000	0.9489
	1.000	1.000	0.497	0.873	0.646	1.000	1.000	1.000	1.000	1.000	0.4935
	1.000	1.000	0.585	0.846	1.000	1.000	1.000	1.000	1.000	1.000	0.9140
	1.000	1.000	0.247	0.551	0.203	1.000	1.000	1.000	1.000	1.000	0.2523

TABLE I.5. (Cont.)

Listener 11										
1.000	1.000	0.437	0.805	0.000	1.000	1.000	1.000	1.000	1.000	0.7085
1.000	1.000	0.490	0.871	0.000	1.000	1.000	1.000	1.000	1.000	0.4856
1.000	1.000	0.214	0.168	0.000	1.000	1.000	1.000	1.000	1.000	0.5330
1.000	1.000	0.252	0.556	0.339	1.000	1.000	1.000	1.000	1.000	0.2627
Listener 12										
1.000	1.000	0.365	0.710	0.000	1.000	1.000	1.000	1.000	1.000	0.6865
1.000	1.000	0.691	0.980	0.933	1.000	1.000	1.000	1.000	1.000	0.7041
1.000	1.000	0.457	0.604	0.941	1.000	1.000	1.000	1.000	1.000	0.7700
1.000	1.000	0.499	0.865	0.972	1.000	1.000	1.000	1.000	1.000	0.5229
Listener 13										
1.000	1.000	0.751	1.000	1.000	1.000	1.000	1.000	1.000	1.000	0.9900
1.000	1.000	0.491	0.857	0.000	1.000	1.000	1.000	1.000	1.000	0.4864
1.000	1.000	0.585	0.816	1.000	1.000	1.000	1.000	1.000	1.000	0.8569
1.000	1.000	0.244	0.490	0.000	1.000	1.000	1.000	1.000	1.000	0.2417
Listener 14										
1.000	1.000	0.804	1.000	1.000	1.000	1.000	1.000	1.000	1.000	0.9945
1.000	1.000	0.772	1.000	1.000	1.000	1.000	1.000	1.000	1.000	0.7835
1.000	1.000	0.722	0.977	1.000	1.000	1.000	1.000	1.000	1.000	0.9871
1.000	1.000	0.439	0.793	0.821	1.000	1.000	1.000	1.000	1.000	0.4597
Listener 15										
1.000	1.000	0.520	0.901	0.390	1.000	1.000	1.000	1.000	1.000	0.8221
1.000	1.000	0.052	0.980	0.901	1.000	1.000	1.000	1.000	1.000	0.6661
1.000	1.000	0.322	0.329	0.000	1.000	1.000	1.000	1.000	1.000	0.0241
1.000	1.000	0.443	0.813	0.922	1.000	1.000	1.000	1.000	1.000	0.4678
Listener 16										
1.000	1.000	0.698	0.955	0.940	1.000	1.000	1.000	1.000	1.000	0.9670
1.000	1.000	0.043	0.977	0.000	1.000	1.000	1.000	1.000	1.000	0.6572
1.000	1.000	0.527	0.089	1.000	1.000	1.000	1.000	1.000	1.000	0.8261
1.000	1.000	0.333	0.638	0.632	1.000	1.000	1.000	1.000	1.000	0.3487
Listener 17										
1.000	1.000	0.710	1.000	0.997	1.000	1.000	1.000	1.000	1.000	0.9880
1.000	1.000	0.593	0.955	0.714	1.000	1.000	1.000	1.000	1.000	0.6048
1.000	1.000	0.547	0.730	1.000	1.000	1.000	1.000	1.000	1.000	0.8010
1.000	1.000	0.281	0.583	0.454	1.000	1.000	1.000	1.000	1.000	0.2949
Listener 18										
1.000	1.000	0.803	1.000	1.000	1.000	1.000	1.000	1.000	1.000	0.9921
1.000	1.000	0.826	1.000	1.000	1.000	1.000	1.000	1.000	1.000	0.8348
1.000	1.000	0.532	0.701	1.000	1.000	1.000	1.000	1.000	1.000	0.8325
1.000	1.000	0.667	0.973	1.000	1.000	1.000	1.000	1.000	1.000	0.6837
Listener 19										
1.000	1.000	0.661	0.970	0.831	1.000	1.000	1.000	1.000	1.000	0.9429
1.000	1.000	1.028	1.000	1.000	1.000	1.000	1.000	1.000	1.000	0.8369
1.000	1.000	0.408	0.010	0.001	1.000	1.000	1.000	1.000	1.000	0.7281
1.000	1.000	0.670	0.979	1.000	1.000	1.000	1.000	1.000	1.000	0.6865
Listener 20										
1.000	1.000	0.477	0.856	0.000	1.000	1.000	1.000	1.000	1.000	0.7204
1.000	1.000	0.010	0.000	0.000	1.000	1.000	1.000	1.000	1.000	0.5099
1.000	1.000	0.195	0.080	0.000	1.000	1.000	1.000	1.000	1.000	0.4883
1.000	1.000	0.279	0.546	0.000	1.000	1.000	1.000	1.000	1.000	0.2746

TABLE I.5. (Cont.)

listener 21										
1.000	1.000	0.716	1.300	1.000	1.000	1.000	1.000	1.000	1.000	0.9686
1.000	1.000	0.719	1.300	1.000	1.000	1.000	1.000	1.000	1.000	0.7327
1.000	1.000	0.064	0.939	1.000	1.000	1.000	1.000	1.000	1.000	0.9661
1.000	1.000	0.521	0.903	1.000	1.000	1.000	1.000	1.000	1.000	0.5453
listener 22										
1.000	1.000	0.170	0.480	0.000	1.000	1.000	1.000	1.000	1.000	0.6320
1.000	1.000	0.455	0.829	0.000	1.000	1.000	1.000	1.000	1.000	0.4522
1.000	1.000	-0.216	0.000	0.000	1.000	1.000	1.000	1.000	1.000	0.4400
1.000	1.000	0.049	0.222	0.000	1.000	1.000	1.000	1.000	1.000	0.0560
listener 23										
1.000	1.000	0.629	0.964	0.057	1.000	1.000	1.000	1.000	1.000	0.8989
1.000	1.000	0.792	1.000	1.000	1.000	1.000	1.000	1.000	1.000	0.8020
1.000	1.000	0.484	0.582	0.940	1.000	1.000	1.000	1.000	1.000	0.7659
1.000	1.000	0.623	0.961	1.000	1.000	1.000	1.000	1.000	1.000	0.6421
listener 24										
1.000	1.000	0.509	0.920	0.000	1.000	1.000	1.000	1.000	1.000	0.7384
1.000	1.000	0.732	1.000	1.000	1.000	1.000	1.000	1.000	1.000	0.7454
1.000	1.000	0.359	0.287	0.446	1.000	1.000	1.000	1.000	1.000	0.6010
1.000	1.000	0.543	0.912	1.000	1.000	1.000	1.000	1.000	1.000	0.5700
listener 25										
1.000	1.000	0.618	0.959	0.509	1.000	1.000	1.000	1.000	1.000	0.8020
1.000	1.000	0.798	1.000	1.000	1.000	1.000	1.000	1.000	1.000	0.8000
1.000	1.000	0.549	0.740	1.000	1.000	1.000	1.000	1.000	1.000	0.8546
1.000	1.000	0.540	0.905	1.000	1.000	1.000	1.000	1.000	1.000	0.5632
listener 26										
1.000	1.000	0.600	0.959	0.743	1.000	1.000	1.000	1.000	1.000	0.9100
1.000	1.000	0.729	1.000	1.000	1.000	1.000	1.000	1.000	1.000	0.7422
1.000	1.000	0.484	0.582	0.940	1.000	1.000	1.000	1.000	1.000	0.7659
1.000	1.000	0.532	0.912	1.000	1.000	1.000	1.000	1.000	1.000	0.5557
listener 27										
1.000	1.000	0.783	1.000	1.000	1.000	1.000	1.000	1.000	1.000	0.9513
1.000	1.000	0.697	0.950	0.940	1.000	1.000	1.000	1.000	1.000	0.7110
1.000	1.000	0.622	0.880	1.000	1.000	1.000	1.000	1.000	1.000	0.9327
1.000	1.000	0.547	0.674	0.992	1.000	1.000	1.000	1.000	1.000	0.5313
listener 28										
1.000	1.000	0.730	1.000	1.000	1.000	1.000	1.000	1.000	1.000	0.9090
1.000	1.000	0.505	0.926	0.000	1.000	1.000	1.000	1.000	1.000	0.5571
1.000	1.000	0.566	0.777	1.000	1.000	1.000	1.000	1.000	1.000	0.8753
1.000	1.000	0.337	0.641	0.154	1.000	1.000	1.000	1.000	1.000	0.3367
listener 29										
1.000	1.000	0.730	1.000	1.000	1.000	1.000	1.000	1.000	1.000	0.9094
1.000	1.000	0.400	0.845	0.000	1.000	1.000	1.000	1.000	1.000	0.4647
1.000	1.000	0.561	0.800	1.000	1.000	1.000	1.000	1.000	1.000	0.8926
1.000	1.000	0.213	0.519	0.000	1.000	1.000	1.000	1.000	1.000	0.2126
listener 30										
1.000	1.000	0.725	1.000	1.000	1.000	1.000	1.000	1.000	1.000	0.9090
1.000	1.000	0.529	0.909	0.434	1.000	1.000	1.000	1.000	1.000	0.5352
1.000	1.000	0.539	0.770	1.000	1.000	1.000	1.000	1.000	1.000	0.8711
1.000	1.000	0.107	0.495	0.000	1.000	1.000	1.000	1.000	1.000	0.1075

TABLE I.5. (Cont.)

listener 31

1.000	1.000	0.389	0.721	0.000	1.000	1.000	1.000	1.000	1.000	0.6898
1.000	1.000	0.406	0.827	0.000	1.000	1.000	1.000	1.000	1.000	0.4024
1.000	1.000	0.373	0.350	0.000	1.000	1.000	1.000	1.000	1.000	0.4681
1.000	1.000	0.223	0.450	0.000	1.000	1.000	1.000	1.000	1.000	0.2220

listener 32

1.000	1.000	0.033	0.988	0.953	1.000	1.000	1.000	1.000	1.000	0.9741
1.000	1.000	0.093	0.989	0.984	1.000	1.000	1.000	1.000	1.000	0.7040
1.000	1.000	0.382	0.444	0.793	1.000	1.000	1.000	1.000	1.000	0.6085
1.000	1.000	0.132	0.440	0.000	1.000	1.000	1.000	1.000	1.000	0.1332

listener 33

1.000	1.000	0.535	0.921	0.000	1.000	1.000	1.000	1.000	1.000	0.7315
1.000	1.000	0.740	1.000	1.000	1.000	1.000	1.000	1.000	1.000	0.7591
1.000	1.000	0.413	0.404	0.713	1.000	1.000	1.000	1.000	1.000	0.0002
1.000	1.000	0.500	0.920	1.000	1.000	1.000	1.000	1.000	1.000	0.5075

listener 34

1.000	1.000	0.421	0.783	0.000	1.000	1.000	1.000	1.000	1.000	0.7035
1.000	1.000	0.711	1.000	1.000	1.000	1.000	1.000	1.000	1.000	0.7250
1.000	1.000	0.107	0.119	0.000	1.000	1.000	1.000	1.000	1.000	2.5000
1.000	1.000	0.515	0.897	1.000	1.000	1.000	1.000	1.000	1.000	0.5392

listener 35

0.680	1.000	0.208	0.501	0.000	1.000	1.000	1.000	1.000	1.000	0.5090
1.000	1.000	0.531	0.853	0.000	1.000	1.000	1.000	1.000	1.000	0.5240
0.992	1.000	0.347	0.344	0.000	1.000	1.000	1.000	1.000	1.000	0.4044
1.000	1.000	0.299	0.579	0.000	1.000	1.000	1.000	1.000	1.000	0.2937

listener 36

1.000	1.000	0.074	0.980	0.000	1.000	1.000	1.000	1.000	1.000	0.9550
1.000	1.000	0.837	1.000	1.000	1.000	1.000	1.000	1.000	1.000	0.8453
1.000	1.000	0.472	0.552	0.917	1.000	1.000	1.000	1.000	1.000	0.7492
1.000	1.000	0.062	0.983	1.000	1.000	1.000	1.000	1.000	1.000	0.0977

listener 37

1.000	1.000	0.332	1.000	1.000	1.000	1.000	1.000	1.000	1.000	0.9933
1.000	1.000	0.875	1.000	1.000	1.000	1.000	1.000	1.000	1.000	0.8014
1.000	1.000	0.675	0.948	1.000	1.000	1.000	1.000	1.000	1.000	0.9710
1.000	1.000	0.733	1.000	1.000	1.000	1.000	1.000	1.000	1.000	0.7407

listener 38

1.000	1.000	0.690	0.994	0.995	1.000	1.000	1.000	1.000	1.000	0.9855
1.000	1.000	0.852	1.000	1.000	1.000	1.000	1.000	1.000	1.000	0.8593
1.000	1.000	0.570	0.823	1.000	1.000	1.000	1.000	1.000	1.000	0.9010
1.000	1.000	0.701	0.997	1.000	1.000	1.000	1.000	1.000	1.000	0.7155

listener 39

1.000	1.000	0.757	1.000	1.000	1.000	1.000	1.000	1.000	1.000	0.9903
1.000	1.000	0.701	0.983	0.954	1.000	1.000	1.000	1.000	1.000	0.7143
1.000	1.000	0.585	0.347	1.000	1.000	1.000	1.000	1.000	1.000	0.9142
1.000	1.000	0.500	0.874	0.993	1.000	1.000	1.000	1.000	1.000	0.5319

listener 40

1.000	1.000	0.910	1.000	1.000	1.000	1.000	1.000	1.000	1.000	0.9904
1.000	1.000	0.911	1.000	1.000	1.000	1.000	1.000	1.000	1.000	0.9152
1.000	1.000	0.707	1.000	1.000	1.000	1.000	1.000	1.000	1.000	1.0000
1.000	1.000	0.673	0.980	1.000	1.000	1.000	1.000	1.000	1.000	0.6890

TABLE I.5. (Cont.)

listener 41											
1.000	1.000	0.737	1.000	1.000	1.000	1.000	1.000	1.000	1.000	1.000	0.9895
1.000	1.000	0.883	1.000	1.000	1.000	1.000	1.000	1.000	1.000	1.000	0.8859
1.000	1.000	0.884	0.952	1.000	1.000	1.000	1.000	1.000	1.000	1.000	0.9732
1.000	1.000	0.741	1.000	1.000	1.000	1.000	1.000	1.000	1.000	1.000	0.7541
listener 42											
1.000	1.000	0.694	0.894	0.941	1.000	1.000	1.000	1.000	1.000	1.000	0.9532
1.000	1.000	0.851	1.000	1.000	1.000	1.000	1.000	1.000	1.000	1.000	0.8587
1.000	1.000	0.497	0.614	0.958	1.000	1.000	1.000	1.000	1.000	1.000	0.7836
1.000	1.000	0.741	0.981	1.000	1.000	1.000	1.000	1.000	1.000	1.000	0.7159
listener 43											
1.000	1.000	0.829	1.000	1.000	1.000	1.000	1.000	1.000	1.000	1.000	0.9932
1.000	1.000	0.884	1.000	1.000	1.000	1.000	1.000	1.000	1.000	1.000	0.8143
1.000	1.000	0.678	0.947	1.000	1.000	1.000	1.000	1.000	1.000	1.000	0.9721
1.000	1.000	0.639	0.908	1.000	1.000	1.000	1.000	1.000	1.000	1.000	0.6568
listener 44											
1.000	1.000	0.820	1.000	1.000	1.000	1.000	1.000	1.000	1.000	1.000	0.9532
1.000	1.000	0.664	0.977	0.840	1.000	1.000	1.000	1.000	1.000	1.000	0.6766
1.000	1.000	0.673	0.943	1.000	1.000	1.000	1.000	1.000	1.000	1.000	0.9682
1.000	1.000	0.430	0.789	0.612	1.000	1.000	1.000	1.000	1.000	1.000	0.4572
listener 45											
1.000	1.000	0.773	1.000	1.000	1.000	1.000	1.000	1.000	1.000	1.000	0.9929
1.000	1.000	0.520	1.000	1.000	1.000	1.000	1.000	1.000	1.000	1.000	0.8351
1.000	1.000	0.619	0.803	1.000	1.000	1.000	1.000	1.000	1.000	1.000	0.9216
1.000	1.000	0.608	0.978	1.000	1.000	1.000	1.000	1.000	1.000	1.000	0.6841
listener 46											
1.000	1.000	0.735	1.000	1.000	1.000	1.000	1.000	1.000	1.000	1.000	0.9894
1.000	1.000	0.741	1.000	1.000	1.000	1.000	1.000	1.000	1.000	1.000	0.7537
1.000	1.000	0.471	0.558	0.915	1.000	1.000	1.000	1.000	1.000	1.000	0.7478
1.000	1.000	0.554	0.917	1.000	1.000	1.000	1.000	1.000	1.000	1.000	0.5763
listener 47											
1.000	1.000	0.733	1.000	1.000	1.000	1.000	1.000	1.000	1.000	1.000	0.9893
1.000	1.000	0.622	0.961	0.610	1.000	1.000	1.000	1.000	1.000	1.000	0.6298
1.000	1.000	0.505	0.775	1.000	1.000	1.000	1.000	1.000	1.000	1.000	0.8743
1.000	1.000	0.404	0.325	0.898	1.000	1.000	1.000	1.000	1.000	1.000	0.4865
listener 48											
1.000	1.000	0.827	1.000	1.000	1.000	1.000	1.000	1.000	1.000	1.000	0.9531
1.000	1.000	0.660	0.978	0.853	1.000	1.000	1.000	1.000	1.000	1.000	0.6784
1.000	1.000	0.675	0.944	1.000	1.000	1.000	1.000	1.000	1.000	1.000	0.9688
1.000	1.000	0.431	0.782	0.792	1.000	1.000	1.000	1.000	1.000	1.000	0.4527
listener 49											
1.000	1.000	0.750	1.000	1.000	1.000	1.000	1.000	1.000	1.000	1.000	0.9515
1.000	1.000	0.797	1.000	1.000	1.000	1.000	1.000	1.000	1.000	1.000	0.8871
1.000	1.000	0.625	0.385	1.000	1.000	1.000	1.000	1.000	1.000	1.000	0.9356
1.000	1.000	0.629	0.904	1.000	1.000	1.000	1.000	1.000	1.000	1.000	0.6470
listener 50											
1.000	1.000	0.773	1.000	1.000	1.000	1.000	1.000	1.000	1.000	1.000	0.9929
1.000	1.000	0.757	1.000	1.000	1.000	1.000	1.000	1.000	1.000	1.000	0.7692
1.000	1.000	0.694	0.373	1.000	1.000	1.000	1.000	1.000	1.000	1.000	0.9292
1.000	1.000	0.576	0.945	1.000	1.000	1.000	1.000	1.000	1.000	1.000	0.5968

rural, urban populations ? 119722, 46573

ptrur	pturb	ptall
0.877	0.957	0.899
0.654	0.820	0.732
0.761	0.886	0.796
0.419	0.663	0.487

**APPENDIX J: RANDOM SELECTION OF POPULATION-WEIGHTED
LISTENING POINTS AT THE INDIAN POINT SITE**

The objective of the listener-site-selection process was to identify 50 randomly selected building locations within the EPZ surrounding the Indian Point Nuclear Plant. These locations are assumed to be residential locations and are called "listener sites."

The various steps used in the site selection procedure are described below:

1. A population-distribution map (see Fig. J-1) consisting of a 10-mile-radius circle divided into annular sectors defined by interior circles and radii, was superimposed on topographical maps of the EPZ. Population distribution information consisted of the number of people within each annular sector. These data were used in order to population-weight the random selection process described below.
2. Each annular sector was first assigned a designator, ranging between A-1 and R-10 (see Fig. J-1). A range of numbers was then assigned to each sector according to the population in that sector. For example, Sector A-1, just north of the site, and sectors B-1 and C-1 (moving clockwise) have zero population and thus were not assigned any numbers. Sector D-1 has a population of 35 and was assigned numbers 1 to 35. Sector E-1 has a population of 60 and was assigned numbers 36 through 95. This process was continued until each number between 1 and 256,015 (the total estimated population) was assigned to a particular sector. A random number

generator (available on a Texas Instruments Model TI-59 hand calculator, for example) was then used to select 50 numbers at random between 1 and 256,015. Each number selected represented one site (to be chosen later) within the sector containing that number. Thus, sectors with larger populations had a greater possibility of including chosen listener sites.

3. Having determined the sector locations of each potential listener site, the next step in the procedure involved selecting the actual sites within the respective sectors. This was accomplished by first over-laying a rectangular coordinate grid on each sector of interest on the topographic map. The grid was composed of boxes with dimensions of approximately 1000 feet square, and each box was assigned an X and a Y coordinate according to its location on the grid. The grid was positioned such that the X-axis was oriented in the east-west direction and the Y-axis was oriented in the north-south direction, and such that all parts of the sector of interest were covered by a positive (X,Y) coordinate pair box. A random number generator was then used to select random pairs of numbers within the X and Y ranges covering the sector of interest. Each X,Y pair was used to select a particular 1000 feet square box on the map. If there were buildings within the box, one of them was arbitrarily chosen as a listener site. If there were no buildings inside the box or if the box fell outside of the sector of interest, that coordinate pair was disregarded and another pair was chosen at random.

For urban sites in the pink "building-extension" area of the topographic map a residential building was always assumed to exist, and was selected at the center of the pink area in the 1000 feet square box.

4. The above process was repeated until 50 listener sites were randomly chosen. It was found, however, that some major urban communities did not include any listener sites, and thus the chosen sites did not properly reflect the population distribution in the EPZ. Therefore, the selection process was continued until this condition was rectified. Four new urban sites were randomly chosen to replace the four most recently chosen rural sites. This replacement only affected the balance between urban and rural listener sites. Since the subsequent analysis treats urban and rural areas separately, this replacement will not bias the results. It will merely ensure that no major population concentrations are ignored. The above procedure resulted in a pseudo-random sample of 50 specific listener locations, distributed throughout the EPZ as shown roughly on Fig. J-1.

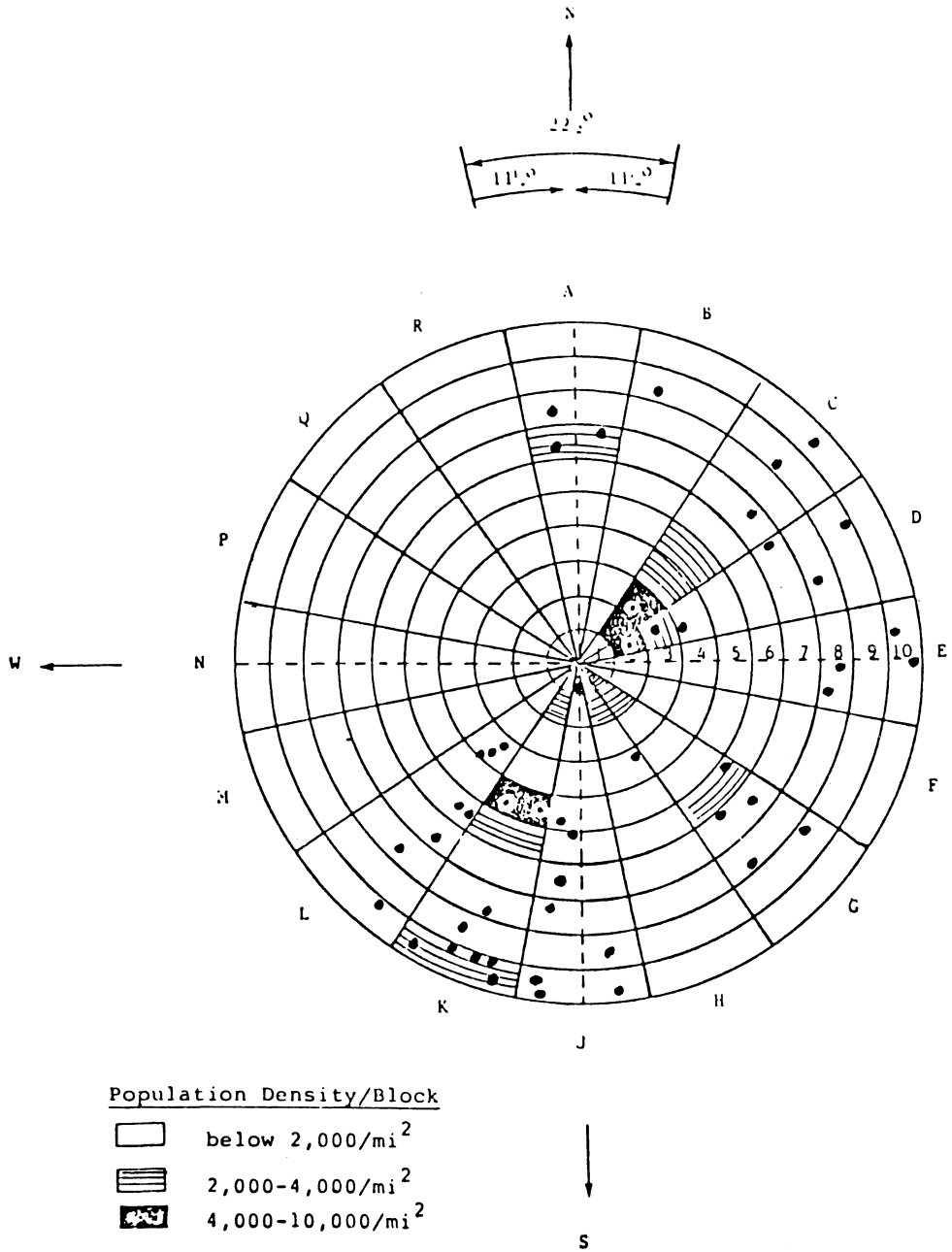

FIG. J-1. SCHEMATIC SECTOR/ZONE DIAGRAM FOR INDIAN POINT EPZ WITH 1980 POPULATION DENSITY DISTRIBUTION.

APPENDIX K: SAMPLE SCENARIOS FOR THE EVALUATION OF SIREN ALERTING AT INDIAN POINT

Scenario	①	②	③	④
Season	Summer	Summer	Winter	Winter
Time of Day	Weekday Afternoon	Late Night	Weekday Evening (Rush Hour)	Late Night
General Weather	Warm, Clear to Partly Cloudy	Warm, Clear to Partly Cloudy	Cold, Overcast	Stormy
Home/Vehicle Windows	Open	Open	Closed (& Storms)	Closed (& Storms)
Temperature, °F	80°	70°	30°	30°
Relative Humidity, %	65%	80%	70%	90%
Temperature Gradient, °F/100 feet (meas. heights=95' & 7')	-1	+0.5	-0.5	-0.5
Wind Direction:				
General	SSE	NNE	NW	SE
Valleys	Up-Valley	Down-Valley	-	-
Wind Speed, mph (meas. height=100')	10 mph	6 mph	10 mph	15 mph
Percent of People Located				
Outdoors	20%	-	5%	-
In Motor Vehicles	6	1%	25	-
Indoors at Work:				
Commercial	23	3	-	4%
Industrial	7	1	-	1
In Home Sleeping	4	95	-	95
In Home Radio/TV	20	-	14	-
In Home Noisy	-	-	3	-
In Home Active	6	-	35	-
In Home Isolated	4	-	14	-
In Home Quiet	10	-	4	-



APPENDIX L: SIREN LOCATIONS FOR THE INDIAN POINT EPZ

This appendix provides existing and proposed siren locations for the Indian Point EPZ as of 25 August 1981. Siren locations are provided on a set of topographical maps (Figures L-2 through L-12). Figure L-1 shows the relationship of the individual maps to the Indian Point EPZ.

A total of 88 125 dBC sirens are employed of which 12 are in Orange County (#1-#12), 24 are in Rockland County (#13-#36), 43 are in Westchester County (#37-#79) and 9 are in Putnam County (#80-#88). Table L.1 provides a guide for locating the sirens on the topographical maps.

TABLE L.1. SIREN LOCATION BY MAP.

<u>Siren #</u>	<u>Map #</u>	<u>Siren #</u>	<u>Map #</u>	<u>Siren #</u>	<u>Map #</u>
1	L-3	31	L-11	61	L-8
2	L-2	32	L-11	62	L-8
3	L-6	33	L-11	63	L-8
4	L-6	34	L-11	64	L-7
5	L-6	35	L-11	65	L-7
6	L-6	36	L-11	66	L-7
7	L-6	37	L-12	67	L-7
8	L-6	38	L-12	68	L-7
9	L-6	39	L-12	69	L-7
10	L-5	40	L-12	70	L-7
11	L-7	41	L-12	71	L-7
12	L-7	42	L-12	72	L-7
13	L-7	43	L-12	73	L-7
14	L-7	44	L-12	74	L-8
15	L-10	45	L-12	75	L-8
16	L-10	46	L-12	76	L-8
17	L-10	47	L-12	77	L-8
18	L-10	48	L-11	78	L-8
19	L-10	49	L-11	79	L-8
20	L-10	50	L-11	80	L-8
21	L-10	51	L-11	81	L-8
22	L-10	52	L-11	82	L-7
23	L-10	53	L-11	83	L-7
24	L-11	54	L-11	84	L-7
25	L-11	55	L-11	85	L-3
26	L-11	56	L-12	86	L-3
27	L-11	57	L-12	87	L-7
28	L-11	58	L-8	88	L-4
29	L-11	59	L-8		
30	L-11	60	L-8		

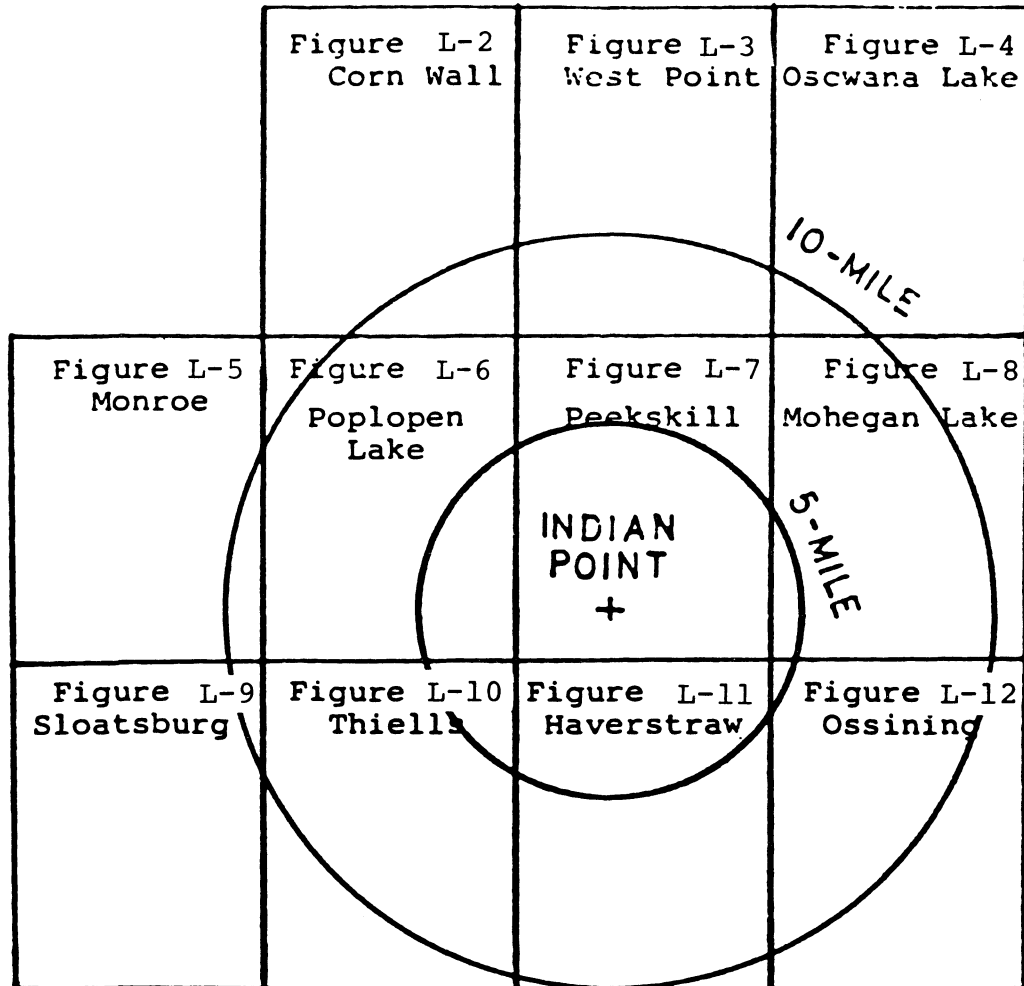

FIG. L-1. SIREN LAYOUT MAP LOCATOR.



Maplet edited and published by the Geological Survey
Under the USGS and USGS
Photograph from aerial photograph by photogrammetric method
Date of photograph taken 1955, 1956. First class 1957
Photograph compiled from USGAS sheet 282 (1964)
Previous editions: 1927 bench map; 1937 bench map; 1957 bench map
USGS sheet of 1955 on base map (topographic series)
1957 bench map; 1957 bench map; 1957 bench map
Date 18. 1957 in use
This map sheet (1:50,000) shows contour lines and spot heights
shown on map in photograph. This information is unclassified
New York State maps in which only
contour lines are shown



Scale 1:50,000
Vertical Datum: 1929 Mean Sea Level
Horizontal Datum: 1929 Mean Sea Level
Projection: Universal Transverse Mercator
Zone: 18
This map is published under authority of the Secretary
FOR SALE BY U. S. GEOLOGICAL SURVEY, WASHINGTON, D. C. 20242
A FOR SALE INFORMATION FORM (GSA GEN. REG. NO. 27) IS AVAILABLE FROM THE
FOR SALE INFORMATION FORM (GSA GEN. REG. NO. 27) IS AVAILABLE FROM THE

NEW CLASSIFICATION
Miscellaneous
Topographic
USGS Sheet
State Sheet
CORNWALL, N. Y.
1957
Date of issue: 1957



Meas. 4845 899 published by the Geological Survey
Control by USGS and USCARS
Photographs from aerial photography by photogrammetric methods
from photographs since 1945. First chart 1947
Photography compiled from USGS 65 (chart 382 (1944))
Reference projection: 1827 North American datum
10,000 foot grid based on Lake Erie datum system, see also
1000 foot Universal Transverse Mercator grid USA
zone 18, shown in blue
For unmarked lines, unless marked force and full name
shown on local photographs. This information is withheld
and not indicated on a map and
boundary boundaries are shown
Unmarked elevations are shown in brown.



SCALE: GRAPHIC
1:50,000
1 inch = 1 mile
1 centimeter = 1000 meters

CONTOUR INTERVAL: 20 FEET
DEPTH CURVES AND RELIEFS: IN FEET - DATUM IS MEAN LOW WATER
UNLESS OTHERWISE INDICATED. SEE NOTE ON REVERSE SIDE
THE MEAN SEA LEVEL IS 1.7 FEET

THIS MAP COMPILED WITH NATIONAL MAP ACCURACY STANDARDS
FOR SALE BY U. S. GEOLOGICAL SURVEY, WASHINGTON, D. C. 20508
A NATIONAL GEOGRAPHIC SOCIETY AND BENTLEY'S IS AVAILABLE ON REQUEST



ROAD CLASSIFICATION
Highways Light-Air
Roadways Unimproved
U. S. Route State Route

WEST POINT, N. Y.
U. S. GEOLOGICAL SURVEY
PHOTOGRAPHIC AND MAP DIVISION
1967
AND SALE BY THE NATIONAL MAP



Map, edited, and published by the Geological Survey
Copies for USGS and USGAS

Topographic from aerial photographs by stereoscopic method
Aerial photographs taken 1958 and 1959. First class 1958

Photographic projection. 1857 North American datum.
IC 8000-foot grid based on New York standard datum, 1885 and
1000-meter Universal Transverse Mercator grid data,
zone 18, shown in blue.

Flow not shown from separate colored lines and light blue
marks on aerial photographs. This information is contained
in published documents on sheets in brown.

SCALE 1:24,000

CONTOUR INTERVAL 20 FEET
EXCEPT IN PLAIN 40 FEET

ROAD CLASSIFICATION

Highway	Light blue
Medium road	Unimproved on
State Road	Circle

OSCAWANA LAKE, N. Y.
U. S. GEOLOGICAL SURVEY
1962 5-107185-7.5
1964
AND SOLD BY THE GEOLOGICAL SURVEY

THIS MAP COMPLETES WITH NATIONAL MAP AGENCY STANDARDS
FOR SALE BY U. S. GEOLOGICAL SURVEY, WASHINGTON, D. C. 20508
A PUBLISHED INFORMATION SUPPLEMENT, MAPS AND CHARTS IS AVAILABLE ON REQUEST



Map compiled and published by the Geological Survey
Control by 1000 and 1000-500
Topographic data aerial photographs by photogrammetry in 1955
Aerial photographs taken 1955 and 1956. First check 1957
Projection: a spherical 1927 North American datum
100,000 feet and based on Mean 1929 spheroidal system
Scale 1:50,000
1:50,000 scale Universal Transverse Mercator grid 1885,
Zone 18, sheet 4
This map should be used in conjunction with the 1:50,000
scale aerial photographs. The information is unclassified



ROAD CLASSIFICATION
 Highway Left Side
 Roadway Unimproved dirt
 U.S. Route State Route

THIS MAP SUPERSEDES ALL PREVIOUS MAPS OF THIS AREA
 FOR SALE BY U.S. GEOLOGICAL SURVEY, WASHINGTON, D.C. 20509
 A PUBLICATION OF THE GEOLOGICAL SURVEY, WASHINGTON, D.C. 20509

MONROE, N.Y.
 NEW YORK STATE GEOLOGICAL SURVEY
 1957

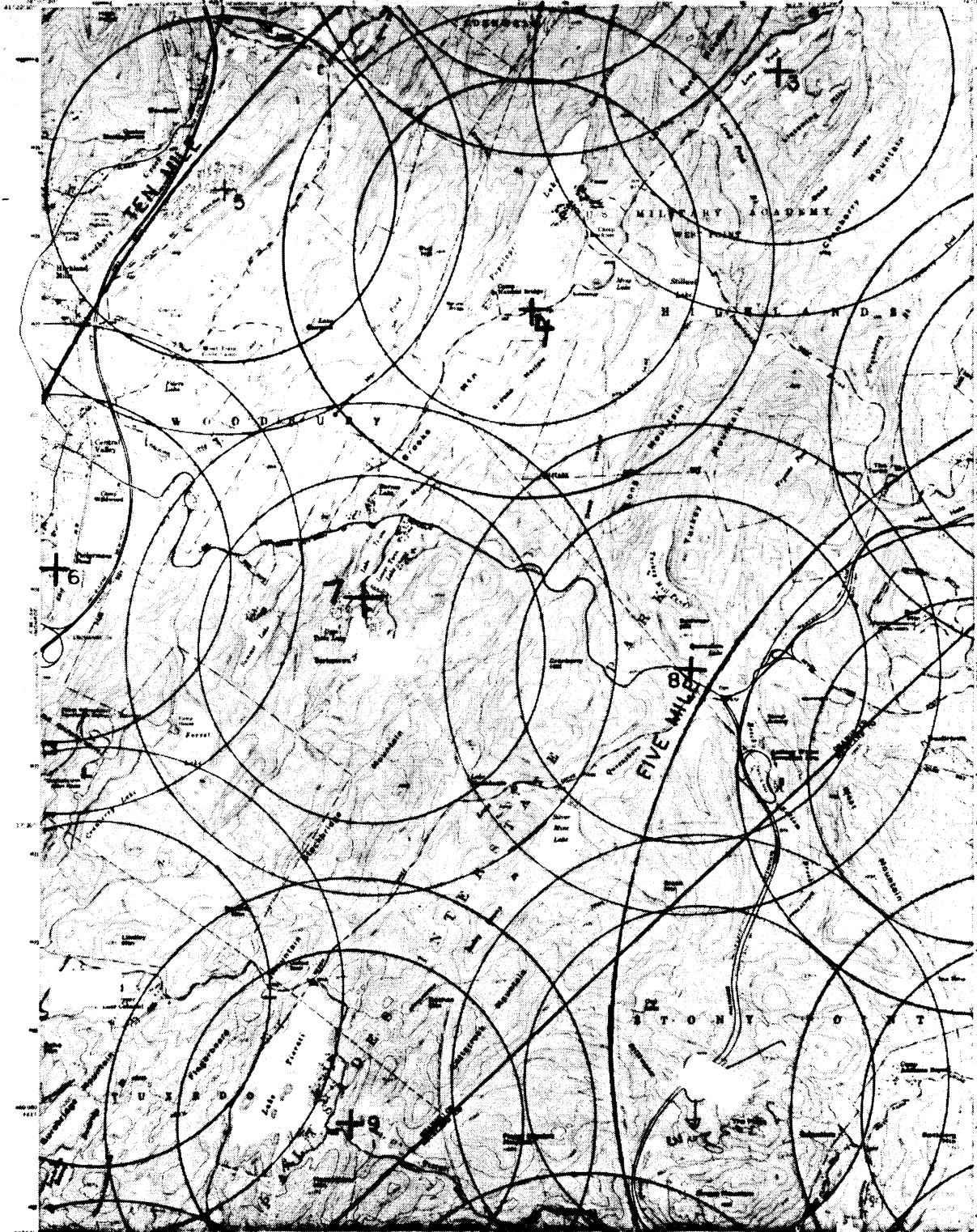

Map compiled and published by the Geological Survey
Contract to USGS and USGS
Topography from aerial photographs by photogrammetric methods
Aerial photographs taken 1955 and 1957. Field notes 1957
Projection, projection: 1983 meters from an datum
17,000 feet @ 4 based on New York coordinate system
and datum
1983 mean Universal Transverse Mercator grid base
zone 18, sheet 11 base
7.5 minute datum used except where noted and field notes
refer to special photographs. This information is unclassified
unless otherwise stated as shown in notes

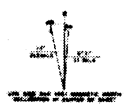

SCALE 1:24,000
CONTOUR INTERVAL 20 FEET
SHOWS 10 FEET HIGHER

ROAD CLASSIFICATION
Main Road
Minor Road
Unimproved dirt
State Road

THIS MAP COMPLETES WITH NATIONAL MAP ACCURACY STANDARDS
AND SHALL BE A U.S. GEOLOGICAL SURVEY INSTRUMENTAL TO C. 1000
A FURTHER INSTRUMENTAL TO THE STATE OF NEW YORK

POPOLOPEN LAKE, N. Y.
7.5 MINUTE SERIES TOPOGRAPHIC
1957
GPO : 1957 : 64-68000-7071



Mapped, edited, and published by the Geological Survey
Controlled by USGS and USGS 8455
Topographic base map of photograph by photogrammetry: Institute
for Photogrammetry, 1965. Field No. 1307
Photographs supplied from USGS chart 242 (1954)
Published pursuant to 1927 North American Datum
12,000-foot grid based on Mean Sea Level coordinate system, east zone
1,000-meter contour. Transverse Mercator grid lines
are 10 meters in length.
The red dashed lines indicate selected base and tied lines
shown on aerial photographs. This information is a check
and not a substitute for field work.
Contours, buildings, and other
uncheckered structures are shown in black.

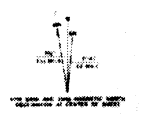

SCALE 1:4000
VERTICAL DATUM: MEAN SEA LEVEL
HORIZONTAL DATUM: NORTH AMERICAN DATUM 1927
CONVERSION INFORMATION: CO. FEET
CONVERSION TO METERS: 1 FOOT = 0.3048 METERS
DEPTH CURVES AND SOUNDINGS IN FEET: CURVES IN 1000 FOOT INTERVALS
UNLESS OTHERWISE INDICATED THE DEPTH CURVES ARE BASED ON MEAN SEA LEVEL
THE SOUNDINGS ARE IN FEET AND METERS
1967
FOR SALE BY U.S. GOVERNMENT PRINTING OFFICE: WASHINGTON, D. C.
A FOLDER INCLUDING TOPOGRAPHIC MAPS AND STUDIES IS AVAILABLE ON REQUEST

ROAD CLASSIFICATION

Major Road	Light Blue
Medium Road	Unshaded Gray
U.S. Route	Black
State Road	Black

PEEKSKILL, N. Y.
7.5 MINUTE SERIES (TOPOGRAPHIC)
SCALE 1:4000
1967
AND 8000 10 1/2 IN. (26.67 CM) DIA.

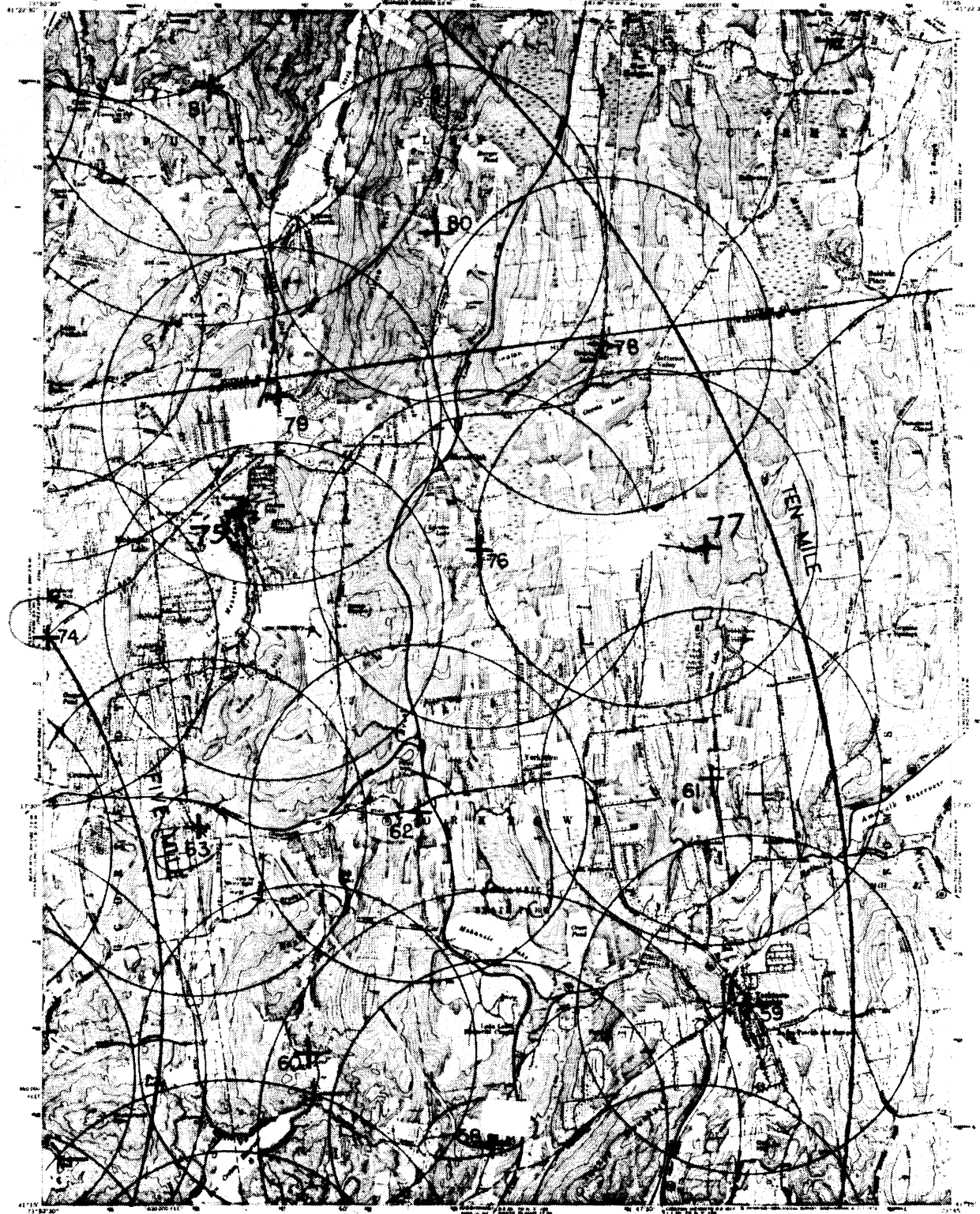

Map published by the Geological Survey
Control by USGS and USACE
Photographs from aerial photographs by photogrammetric methods
Vertical projection used: UTM, zone 18N, datum: 1983
Horizontal projection: 1983 North American datum
Datum: 1983 North American datum
Scale: 1:50,000
Contour interval: 20 feet
Elevation: 100 feet
This map is based on the best available data and field notes
derived from aerial photographs. The information is considered
reliable for general use.



ROAD CLASSIFICATION
Main Road 100-000
Secondary Road 200-000
Tertiary Road 300-000
State Road 400-000
Mileage 500-000
Scale 1:50,000
MOHEGAN LAKE, N. Y.
NEW YORK STATE GEOLOGICAL SURVEY
ALBANY, N. Y. 12242-1500
1984
ANNALS OF THE SURVEY 1984



Map made, edited, and published by the Geological Survey
conform to USGS, 1:50,000 scale, and U.S. Permanent Frame Conventions.
Topographic features photographed by Reid A. B.
for the Geological Survey, 1927-1928 (check 1955).
Photographic projection: 1927 North American Datum.
Elevations based on the datum of New York and New Jersey, which
are nearly all New Jersey elevations, except
1. U.S. Coast and Geodetic Survey, New York and New Jersey,
July 18, 1899, in New York.



ROAD CLASSIFICATION

Highway —————
Expressway —————
U.S. Road —————
Other Road —————

U.S. GEOLOGICAL SURVEY
WASHINGTON, D. C. 20542
FOR SALE BY U.S. GEOLOGICAL SURVEY, WASHINGTON, D. C. 20542
A FOLDER RECEIVING TOPOGRAPHIC MAPS AND SERIES IS AVAILABLE ON REQUEST

SLOATSBURG, N. Y. N. J.
1955
AND BASE D. P. W. SERIES 1947



Prepared, edited, and published by the Geological Survey
Checked by USGS, USCGAS, and N. Y. Paradise Park Commission
Topography from aerial photographs by stereogrammetric
methods. Aerial photographs, March 1947; 1:50,000 scale, 1947
Photographic projection: 1927 spheroid of Clarke
EQUATORIAL GRID BASED ON NEW YORK COAST AND GULF
COAST LINE
1:50,000 scale International Standard Mercator projection
Zone 18, datum in feet
Vertical datum: mean sea level
Scale: 1:50,000
UNITED STATES GEOLOGICAL SURVEY
WASHINGTON, D. C. 20508
FOR SALE BY U. S. GEOLOGICAL SURVEY, WASHINGTON, D. C. 20508
A FOLDER CONTAINING PHOTOGRAPHIC WORK SHEETS IS AVAILABLE ON REQUEST

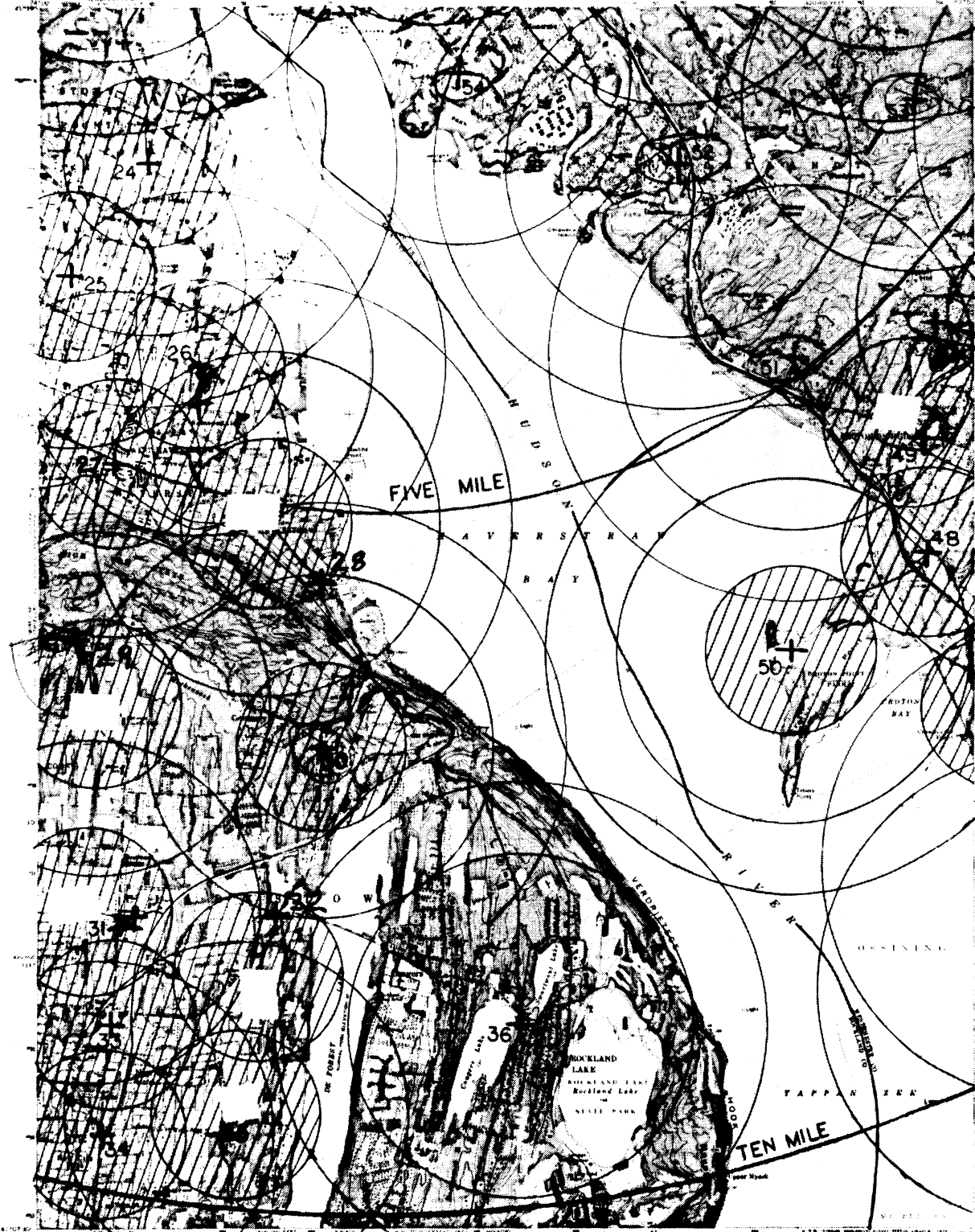

Revised 1958 and published by the Geological Survey

Control by 1948 and 1954 data

Topography by aneroid and leveling; aerial photography since 1948; and stadia 1957

Substratum from 1955

Sectional map prepared from USGS Chart 892 (1954)

This information is not intended for navigation purposes

Published under authority of the Department of the Interior, Geological Survey

Copyright © 1958 by the Geological Survey

Scale 1:24,000

Horizontal scale 1 inch = 2000 feet

Vertical scale 1 inch = 100 feet

Contour interval 20 feet

Spot heights in feet

Spot heights in feet

Spot heights in feet

Spot heights in feet

Scale 1:24,000

Horizontal scale 1 inch = 2000 feet

Vertical scale 1 inch = 100 feet

Contour interval 20 feet

Spot heights in feet

Spot heights in feet

Spot heights in feet

Spot heights in feet

Scale 1:24,000

Horizontal scale 1 inch = 2000 feet

Vertical scale 1 inch = 100 feet

Contour interval 20 feet

Spot heights in feet

Spot heights in feet

Spot heights in feet

Spot heights in feet

Scale 1:24,000

Horizontal scale 1 inch = 2000 feet

Vertical scale 1 inch = 100 feet

Contour interval 20 feet

Spot heights in feet

Spot heights in feet

Spot heights in feet

Spot heights in feet



Map of the Osburning Quadrangle, New York, Westchester County, 7.5-minute series (topographic). The map is a detailed topographic representation of the area, showing terrain, roads, and railroads. It is heavily annotated with a dense network of black lines, likely representing a specific study or data overlay. The terrain is depicted with contour lines, and various geographical features like rivers and roads are clearly marked.

Map Information:
 Original source and published by the Geological Survey
 Date of publication: 1960 and 1967 (Final sheet 1967)
 Contour interval: 20 feet
 Scale: 1:50,000
 Projection: UTM
 Datum: NAD 83
 Contour interval: 20 feet
 Scale: 1:50,000
 Projection: UTM
 Datum: NAD 83

ROAD CLASSIFICATION

Highway	Light duty
State route	Unimproved dirt
U.S. Route	State Route

OSBURNING, N. Y.
 7.5-MINUTE SERIES (TOPOGRAPHIC)
 1967
 7.5-MINUTE SERIES (TOPOGRAPHIC)
 1967

APPENDIX M: ANALYSIS INPUT/OUTPUT DATA FOR INDIAN POINT

This appendix provides listings of computer file input and output data for the Zion analysis. Explanation of the terminology used for each listing is provided below.

TABLE M.1. INDIAN-SIRENS

This file contains input data for each of the Indian Point sirens as follows:

- Siren No. number assigned to each siren for use by computer program.
- Siren Name first letter indicates whether the siren is rotating or stationary type (R or S); the remainder consists of the siren designation, which for this plant is identical to the Siren No.
- x,y,z these are the physical coordinates for the siren location; the x-axis is oriented east-west, the y-axis is oriented north-south, and the z-axis is oriented vertically. The x and y coordinates are in units of km, referenced to the grid shown on the Feb. 1981 NRC Emergency Planning Map for Indian Point (the plant center is located approximately at x = 587.7, y = 4569.2). The z coordinates are in units of feet.
- SPL@100FT these numbers indicate the rated sound pressure level for each siren at a distance of 100 feet, in dB

Table M.2 INDIANEARS

This file contains input data for each of the randomly selected listener locations as follows:

- Site No. number assigned to each site for use by computer program
- Site Name designator for listener site; the first letter indicates whether the site is urban or rural (U or R)
- x,y,z these are the physical coordinates for the listener location; the x-axis is oriented east-west, the y-axis is oriented north-south, and the z-axis is oriented vertically. The x and y coordinates are in units of km, referenced to the grid shown on the Feb. 1981 NRC Emergency Planning Map for Indian Point (the plant center is located approximately at x=587.7, y=4569.2). The z coordinates are in units of feet
- Rural Road this column indicates whether rural listener sites are within 1000 ft of major highway (NEAR) or beyond 1000 ft (FAR). This information is required for the selection of appropriate outdoor background noise levels.

TABLE M.3 VAL-HUDSON

This file contains input data for each of the four sample scenarios as follows:

- Scenario No. number assigned to each scenario (see App. J).
- AMOL molecular absorption, in dB/1000 feet.

- WIND wind direction in degrees (0° = wind from north, etc.)
- NRES residential building outdoor-to-indoor noise reduction, in dB.
- NCRM commercial building outdoor-to-indoor noise reduction, in dB.
- F1 - F8 activity fractions.
 - F1 = fraction of people outdoors.
 - F2 = fraction of people indoors, at home, listening to radio or TV.
 - F3 = fraction of people indoors, at home, sleeping.
 - F4 = fraction of people indoors, at home, neither sleeping nor listening to radio or TV.
 - F5 = fraction of people indoors, at work, in commercial establishments.
 - F6 = fraction of people indoors, at work, in industrial locations.
 - F7 = fraction of people in vehicles in urban areas at 30 mph.
 - F8 = fraction of people in vehicles in rural areas at 55 mph.
- INP indoor alert probability curve (see Fig. 4-4 of text).
- PU30 probability of alert for motorists in urban areas at 30 mph.
- PR55 probability of alert for motorists in rural areas at 55 mph.
- MUL vertical profile of wind speed, βz , in ft/sec/ln ft.

- ADD vertical profile of air temperature, a, in °F/ln ft.

TABLE M.4 LISTENEROUTPUT

This listing provides the number, name and outdoor sound pressure level (LOUT, in dB) for the "dominant" siren at each sample listener location, for each of the four sample scenarios. The results are listed in numerical order for scenarios one through four for each listener site.

TABLE M.5 PROBS

This listing provides the final results for the analysis. Information is listed in numerical order for scenarios one through four for each listener site. This information consists of alert probabilities P1 through P8 corresponding to activity fractions F1 through F8, as well as the total probability of alert (PT) for each sample scenario at each sample listener site.

A summary is provided at the end of the listing showing the rural and urban population followed by the total rural probability of alert (PTRUR), the total urban probability of alert (PTURB), and the total (population-weighted) probability of alert for the EPZ (PTALL). The total probability values are listed in numerical order for sample scenarios one through four.

TABLE M.1

INDIAN-SIRENS		X	Y	Z	SPL@100 FT
SIREN#	SIREN NAME				
1	R1	586.150	4583.250	250.000	125
2	R2	578.750	4584.400	530.000	125
3	R3	581.400	4579.850	830.000	125
4	R4	578.750	4577.060	770.000	125
5	R5	575.200	4578.400	830.000	125
6	R6	573.400	4574.250	570.000	125
7	R7	576.850	4573.800	990.000	125
8	R8	580.570	4573.070	650.000	125
9	R9	576.820	4567.900	1070.000	125
10	R10	573.050	4569.000	880.000	125
11	R11	586.500	4580.000	200.000	125
12	R12	584.800	4576.000	210.000	125
13	R13	583.750	4571.950	370.000	125
14	R14	584.500	4568.120	630.000	125
15	R15	580.120	4554.200	560.000	125
16	R16	574.100	4564.380	890.000	125
17	R17	576.180	4562.150	1150.000	125
18	R18	579.830	4564.750	650.000	125
19	R19	581.680	4563.500	435.000	125
20	R20	582.000	4560.100	520.000	125
21	R21	578.880	4560.680	550.000	125
22	R22	578.220	4557.660	620.000	125
23	R23	581.050	4557.150	615.000	125
24	R24	585.050	4565.050	160.000	125
25	R25	584.200	4563.750	170.000	125
26	R26	585.650	4562.350	125.000	125
27	R27	584.700	4561.700	280.000	125
28	R28	587.100	4560.300	90.000	125
29	R29	584.350	4559.600	180.000	125
30	R30	587.080	4558.450	270.000	125
31	R31	585.000	4556.480	180.000	125
32	R32	586.620	4556.500	130.000	125
33	R33	584.750	4555.250	215.000	125
34	R34	584.700	4554.050	270.000	125
35	R35	586.050	4554.000	200.000	125
36	R36	589.400	4555.300	195.000	125
37	R37	595.600	4556.150	230.000	125
38	R38	597.550	4556.800	430.000	125
39	R39	595.500	4557.250	220.000	125
40	R40	597.380	4557.900	415.000	125
41	R41	596.200	4558.700	260.000	125
42	R42	594.720	4559.380	150.000	125
43	R43	597.420	4560.030	530.000	125
44	R44	599.250	4559.500	580.000	125
45	R45	600.580	4562.950	530.000	125
46	R46	597.600	4562.320	390.000	125
47	R47	595.050	4561.050	360.000	125
48	R48	594.850	4560.750	110.000	125
49	R49	593.850	4562.000	180.000	125
50	R50	592.380	4559.600	60.000	125

TABLE M.1. (Cont.)

51	R51	592.350	4562.920	230.000	125
52	R52	591.000	4565.100	180.000	125
53	R53	593.670	4565.800	360.000	125
54	R54	588.550	4566.100	100.000	125
55	R55	593.950	4563.330	430.000	125
56	R56	596.400	4565.650	330.000	125
57	R57	601.620	4567.000	460.000	125
58	R58	599.450	4567.700	498.000	125
59	R59	602.270	4569.350	490.000	125
60	R60	597.300	4568.700	290.000	125
61	R61	601.870	4571.870	470.000	125
62	R62	598.500	4571.500	530.000	125
63	R63	595.900	4571.300	490.000	125
64	R64	593.100	4568.750	380.000	125
65	R65	590.900	4567.700	270.000	125
66	R66	588.200	4568.600	150.000	125
67	R67	589.700	4569.500	170.000	125
68	R68	589.950	4570.700	200.000	125
69	R69	591.350	4571.450	310.000	125
70	R70	590.100	4572.450	280.000	125
71	R71	588.000	4572.120	130.000	125
72	R72	591.600	4574.550	150.000	125
73	R73	593.000	4571.970	450.000	125
74	R74	594.220	4573.500	370.000	125
75	R75	596.620	4574.880	750.000	125
76	R76	599.180	4574.550	540.000	125
77	R77	601.800	4574.620	675.000	125
78	R78	600.500	4576.900	650.000	125
79	R79	596.800	4576.300	450.000	125
80	R80	598.600	4578.220	750.000	125
81	R81	595.920	4579.870	510.000	125
82	R82	593.820	4577.450	330.000	125
83	R83	590.400	4578.620	570.000	125
84	R84	587.170	4576.070	250.000	125
85	R85	588.370	4581.350	200.000	125
86	R86	590.700	4584.650	450.000	125
87	R87	592.500	4580.030	570.000	125
88	R88	595.050	4581.650	720.000	125

TABLE M.2.
INDIANEARS

SITE #	SITE NAME	X	Y	Z	RURAL ROAD
1	R1	587.600	4567.820	60.000	FAR
2	U2	590.000	4569.950	150.000	-
3	R3	592.250	4570.850	380.000	FAR
4	U4	584.450	4565.120	170.000	-
5	R5	590.370	4564.800	150.000	FAR
6	R6	583.720	4564.600	130.000	FAR
7	R7	583.350	4564.350	200.000	FAR
8	U8	586.600	4561.220	30.000	-
9	U9	586.050	4561.600	30.000	-
10	R10	583.850	4562.100	180.000	FAR
11	R11	594.350	4564.450	490.000	FAR
12	U12	586.820	4561.100	30.000	-
13	R13	582.550	4561.800	300.000	FAR
14	R14	582.350	4561.850	340.000	FAR
15	R15	586.450	4579.100	140.000	NEAR
16	R16	589.320	4580.100	380.000	NEAR
17	R17	595.850	4576.150	500.000	FAR
18	R18	596.300	4574.900	500.000	FAR
19	R19	595.800	4562.800	350.000	FAR
20	U20	594.100	4562.050	150.000	-
21	R21	586.750	4558.850	220.000	FAR
22	R22	581.070	4560.400	540.000	NEAR
23	R23	586.350	4580.650	200.000	NEAR
24	U24	589.950	4571.600	200.000	-
25	R25	598.850	4572.650	490.000	NEAR
26	R26	599.850	4568.520	535.000	NEAR
27	R27	599.150	4567.700	360.000	FAR
28	U28	595.370	4559.200	380.000	-
29	R29	586.000	4557.750	90.000	FAR
30	R30	583.150	4557.150	285.000	FAR
31	R31	579.150	4560.220	515.000	FAR
32	R32	591.320	4581.750	700.000	FAR
33	R33	596.750	4578.270	240.000	FAR
34	R34	600.100	4576.200	440.000	NEAR
35	R35	598.150	4561.600	500.000	NEAR
36	R36	589.350	4555.600	145.000	NEAR
37	R37	582.450	4556.600	430.000	FAR
38	R38	598.850	4579.650	840.000	FAR
39	R39	602.270	4570.350	440.000	NEAR
40	R40	603.290	4569.220	460.000	FAR
41	R41	589.150	4553.570	205.000	NEAR
42	U42	591.100	4570.750	310.000	-
43	U43	585.150	4553.800	255.000	-
44	U44	585.200	4553.350	245.000	-
45	U45	584.100	4553.650	280.000	-
46	U46	584.150	4554.850	210.000	-
47	R47	583.550	4555.100	340.000	FAR
48	R48	582.150	4555.600	475.000	NEAR
49	R49	580.150	4555.750	460.000	FAR
50	R50	578.550	4557.620	510.000	FAR

TABLE M.3.

VAL-HUDSON

SCEN#	AMDL	WIND	NRES	NCRM	F1	F2	F3	F4	F5	F6	F7	F8
1	0.85	158	16.	31.	.200	.200	.040	.200	.230	.070	.026	.034
2	0.81	23	16.	31.	.000	.000	.950	.000	.030	.010	.004	.006
3	0.49	315	31.	31.	.050	.140	.000	.560	.000	.000	.108	.142
4	0.46	135	31.	31.	.000	.000	.950	.000	.040	.010	.000	.000

INP	PU30	PR55	MUL	ADD
1	1.000	1.000	3.750	-0.350
3	1.000	1.000	2.250	0.170
3	1.000	1.000	3.750	-0.170
1	1.000	1.000	5.620	-0.170

TABLE M.4.
LISTENEROUTPUT

LIS #	LISTENER NAME	SIREN #	SIREN NAME	LDUT
1	R1	54	R54	83.3
		66	R66	92.2
		66	R66	93.2
		54	R54	85.8
2	U2	67	R67	98.5
		68	R68	95.2
		68	R68	95.9
		67	R67	99.2
3	R3	64	R64	74.3
		73	R73	88.5
		73	R73	89.9
		64	R64	77.2
4	U4	25	R25	87.9
		14	R14	77.1
		14	R14	80.3
		25	R25	89.7
5	R5	52	R52	80.9
		52	R52	96.0
		52	R52	81.7
		52	R52	96.8
6	R6	25	R25	92.2
		25	R25	77.3
		25	R25	73.3
		25	R25	93.4
7	R7	25	R25	91.4
		14	R14	72.3
		14	R14	76.4
		25	R25	92.8
8	U8	28	R28	91.4
		26	R26	87.4
		26	R26	88.9
		28	R28	92.7
9	U9	28	R28	85.6
		26	R26	93.8
		26	R26	94.7
		28	R28	87.7
10	R10	27	R27	92.6
		25	R25	85.7
		25	R25	87.4
		27	R27	93.8

TABLE M.4. (Cont.)

11	R11	55	R55	79.7
		56	R56	80.8
		51	R51	67.3
		56	R56	83.6
12	U12	28	R28	93.8
		26	R26	85.5
		26	R26	87.3
		28	R28	94.8
13	R13	20	R20	74.1
		27	R27	73.6
		25	R25	65.7
		20	R20	76.4
14	R14	27	R27	78.0
		27	R27	78.3
		19	R19	76.7
		27	R27	81.0
15	R15	84	R84	76.1
		11	R11	93.2
		11	R11	94.1
		84	R84	80.1
16	R16	85	R85	66.4
		85	R85	86.6
		85	R85	88.2
		85	R85	68.4
17	R17	75	R75	87.1
		82	R82	80.6
		82	R82	83.2
		75	R75	89.0
18	R18	75	R75	103.4
		75	R75	103.4
		75	R75	93.8
		75	R75	103.8
19	R19	46	R46	68.8
		56	R56	77.7
		55	R55	85.9
		46	R46	71.2
20	U20	49	R49	105.8
		49	R49	105.9
		49	R49	106.1
		49	R49	101.2

TABLE M.4. (Cont.)

21	R21	30	R30	98.9
		30	R30	94.0
		30	R30	84.5
		30	R30	99.6
22	R22	20	R20	92.2
		20	R20	92.3
		19	R19	79.6
		20	R20	93.4
23	R23	11	R11	96.3
		85	R85	82.4
		11	R11	77.1
		11	R11	97.2
24	U24	68	R68	93.1
		70	R70	93.7
		70	R70	94.6
		68	R68	94.2
25	R25	62	R62	89.7
		76	R76	83.9
		76	R76	85.9
		62	R62	91.3
26	R26	58	R58	92.9
		58	R58	73.1
		58	R58	79.0
		58	R58	94.1
27	R27	58	R58	104.2
		58	R58	104.2
		58	R58	99.6
		58	R58	104.6
28	U28	41	R41	92.2
		42	R42	96.3
		42	R42	97.0
		41	R41	93.5
29	R29	32	R32	87.9
		30	R30	89.1
		29	R29	82.8
		30	R30	90.5
30	R30	33	R33	79.8
		29	R29	78.7
		29	R29	81.6
		33	R33	83.0

TABLE M.4. (Cont.)

31	R31	21	R21	83.6
		21	R21	98.7
		21	R21	99.3
		22	R22	81.9
32	R32	83	R83	71.1
		88	R88	58.6
		85	R85	62.7
		83	R83	75.3
33	R33	79	R79	64.6
		81	R81	62.2
		81	R81	64.1
		79	R79	67.1
34	R34	77	R77	80.9
		78	R78	94.4
		78	R78	95.2
		77	R77	83.9
35	R35	46	R46	73.0
		46	R46	93.1
		46	R46	94.1
		44	R44	74.6
36	R36	36	R36	104.2
		36	R36	99.2
		36	R36	99.5
		36	R36	104.5
37	R37	31	R31	79.4
		31	R31	79.7
		29	R29	78.0
		31	R31	82.7
38	R38	80	R80	87.4
		80	R80	67.6
		80	R80	69.1
		80	R80	89.2
39	R39	59	R59	91.9
		61	R61	86.6
		61	R61	88.2
		59	R59	93.2
40	R40	59	R59	71.6
		59	R59	81.7
		59	R59	92.8
		59	R59	72.9

TABLE M.4. (Cont.)

41	R41	36	R36	55.3
		36	R36	75.6
		36	R36	77.4
		36	R36	57.6
42	U42	68	R68	85.2
		68	R68	90.4
		68	R68	91.6
		68	R68	71.7
43	U43	35	R35	92.8
		34	R34	99.1
		34	R34	99.6
		35	R35	94.0
44	U44	35	R35	71.1
		35	R35	91.2
		34	R34	83.5
		35	R35	92.5
45	U45	34	R34	85.5
		34	R34	95.6
		33	R33	87.2
		34	R34	96.4
46	U46	34	R34	92.2
		33	R33	95.6
		33	R33	86.4
		33	R33	96.4
47	R47	33	R33	89.7
		33	R33	89.8
		33	R33	71.1
		33	R33	91.2
48	R48	33	R33	79.0
		33	R33	79.3
		23	R23	70.8
		33	R33	82.3
49	R49	15	R15	86.5
		23	R23	75.7
		23	R23	77.5
		15	R15	88.5
50	R50	22	R22	98.3
		22	R22	103.3
		22	R22	103.7
		22	R22	93.7

TABLE M.5.

PROBS

	P1	P2	P3	P4	P5	P6	P7	P8	P1
LISTENER 1	1.000	1.000	0.691	0.989	0.986	1.000	1.000	1.000	0.9822
	1.000	1.000	0.790	1.000	1.000	1.000	1.000	1.000	0.8001
	1.000	1.000	0.625	0.900	1.000	1.000	1.000	1.000	0.9441
LISTENER 2	1.000	1.000	0.519	0.900	1.000	1.000	1.000	1.000	0.5429
	1.000	1.000	0.848	1.000	1.000	1.000	1.000	1.000	0.9939
	1.000	1.000	0.818	1.000	1.000	1.000	1.000	1.000	0.8274
	1.000	1.000	0.661	0.937	1.000	1.000	1.000	1.000	0.9645
LISTENER 3	1.000	1.000	0.701	0.998	1.000	1.000	1.000	1.000	0.7160
	1.000	1.000	0.569	0.941	0.614	1.000	1.000	1.000	0.8823
	1.000	1.000	0.751	0.999	1.000	1.000	1.000	1.000	0.7630
	1.000	1.000	0.579	0.837	1.000	1.000	1.000	1.000	0.9089
LISTENER 4	1.000	1.000	0.377	0.716	0.780	1.000	1.000	1.000	0.3993
	1.000	1.000	0.744	1.000	1.000	1.000	1.000	1.000	0.9898
	1.000	1.000	0.610	0.882	0.780	1.000	1.000	1.000	0.6230
	1.000	1.000	0.430	0.547	0.902	1.000	1.000	1.000	0.7461
LISTENER 5	1.000	1.000	0.576	0.945	1.000	1.000	1.000	1.000	0.5971
	1.000	1.000	0.659	0.982	0.917	1.000	1.000	1.000	0.9638
	1.000	1.000	0.826	1.000	1.000	1.000	1.000	1.000	0.8344
	1.000	1.000	0.453	0.595	0.936	1.000	1.000	1.000	0.7735
LISTENER 6	1.000	1.000	0.671	0.985	1.000	1.000	1.000	1.000	0.6873
	1.000	1.000	0.789	1.000	1.000	1.000	1.000	1.000	0.9916
	1.000	1.000	0.612	0.884	0.787	1.000	1.000	1.000	0.6252
	1.000	1.000	0.309	0.304	0.554	1.000	1.000	1.000	0.6105
LISTENER 7	1.000	1.000	0.627	0.971	1.000	1.000	1.000	1.000	0.6460
	1.000	1.000	0.782	1.000	1.000	1.000	1.000	1.000	0.9913
	1.000	1.000	0.540	0.772	0.485	1.000	1.000	1.000	0.5480
	1.000	1.000	0.364	0.408	0.743	1.000	1.000	1.000	0.6686
LISTENER 8	1.000	1.000	0.619	0.968	1.000	1.000	1.000	1.000	0.6377
	1.000	1.000	0.781	1.000	1.000	1.000	1.000	1.000	0.9912
	1.000	1.000	0.738	0.994	1.000	1.000	1.000	1.000	0.7511
	1.000	1.000	0.565	0.814	1.000	1.000	1.000	1.000	0.8960
LISTENER 9	1.000	1.000	0.618	0.967	1.000	1.000	1.000	1.000	0.6368
	1.000	1.000	0.717	1.000	1.000	1.000	1.000	1.000	0.9887
	1.000	1.000	0.806	1.000	1.000	1.000	1.000	1.000	0.8153
	1.000	1.000	0.645	0.922	1.000	1.000	1.000	1.000	0.9561
LISTENER 10	1.000	1.000	0.547	0.924	1.000	1.000	1.000	1.000	0.5693
	1.000	1.000	0.794	1.000	1.000	1.000	1.000	1.000	0.9917
	1.000	1.000	0.718	0.974	1.000	1.000	1.000	1.000	0.7324
	1.000	1.000	0.543	0.776	1.000	1.000	1.000	1.000	0.8746
	1.000	1.000	0.633	0.973	1.000	1.000	1.000	1.000	0.6509

TABLE M.5. (Cont.)

LISTENER 11	1.000	1.000	1.000	1.000	1.000	0.978	0.645	0.978	0.885	1.000	1.000	1.000	1.000	1.000	1.000	0.9549
	1.000	1.000	1.000	1.000	1.000	0.935	0.659	0.935	0.917	1.000	1.000	1.000	1.000	1.000	1.000	0.6739
	1.000	1.000	1.000	1.000	1.000	0.195	0.195	0.146	0.000	1.000	1.000	1.000	1.000	1.000	1.000	0.5220
	1.000	1.000	1.000	1.000	1.000	0.484	0.484	0.864	0.992	1.000	1.000	1.000	1.000	1.000	1.000	0.5091
LISTENER 12	1.000	1.000	1.000	1.000	1.000	1.000	0.805	1.000	1.000	1.000	1.000	1.000	1.000	1.000	1.000	0.9922
	1.000	1.000	1.000	1.000	1.000	0.973	0.716	0.973	1.000	1.000	1.000	1.000	1.000	1.000	1.000	0.7302
	1.000	1.000	1.000	1.000	1.000	0.540	0.540	0.771	1.000	1.000	1.000	1.000	1.000	1.000	1.000	0.8720
	1.000	1.000	1.000	1.000	1.000	0.646	0.646	0.978	1.000	1.000	1.000	1.000	1.000	1.000	1.000	0.6639
LISTENER 13	1.000	1.000	1.000	1.000	1.000	0.567	0.567	0.939	0.605	1.000	1.000	1.000	1.000	1.000	1.000	0.8798
	1.000	1.000	1.000	1.000	1.000	0.808	0.561	0.808	0.576	1.000	1.000	1.000	1.000	1.000	1.000	0.5698
	1.000	1.000	1.000	1.000	1.000	0.162	0.162	0.116	0.000	1.000	1.000	1.000	1.000	1.000	1.000	0.5047
	1.000	1.000	1.000	1.000	1.000	0.364	0.364	0.694	0.741	1.000	1.000	1.000	1.000	1.000	1.000	0.3853
LISTENER 14	1.000	1.000	1.000	1.000	1.000	0.621	0.621	0.969	0.818	1.000	1.000	1.000	1.000	1.000	1.000	0.9369
	1.000	1.000	1.000	1.000	1.000	0.626	0.626	0.901	0.832	1.000	1.000	1.000	1.000	1.000	1.000	0.6393
	1.000	1.000	1.000	1.000	1.000	0.418	0.369	0.418	0.757	1.000	1.000	1.000	1.000	1.000	1.000	0.6739
	1.000	1.000	1.000	1.000	1.000	0.812	0.442	0.812	0.921	1.000	1.000	1.000	1.000	1.000	1.000	0.4666
LISTENER 15	1.000	1.000	1.000	1.000	1.000	0.596	0.596	0.957	0.726	1.000	1.000	1.000	1.000	1.000	1.000	0.9123
	1.000	1.000	1.000	1.000	1.000	0.799	0.799	1.000	1.000	1.000	1.000	1.000	1.000	1.000	1.000	0.8094
	1.000	1.000	1.000	1.000	1.000	0.637	0.637	0.914	1.000	1.000	1.000	1.000	1.000	1.000	1.000	0.9516
	1.000	1.000	1.000	1.000	1.000	0.427	0.427	0.792	0.897	1.000	1.000	1.000	1.000	1.000	1.000	0.4518
LISTENER 16	1.000	1.000	1.000	1.000	1.000	0.448	0.448	0.820	0.000	1.000	1.000	1.000	1.000	1.000	1.000	0.7120
	1.000	1.000	1.000	1.000	1.000	0.729	0.729	0.981	1.000	1.000	1.000	1.000	1.000	1.000	1.000	0.7425
	1.000	1.000	1.000	1.000	1.000	0.555	0.555	0.797	1.000	1.000	1.000	1.000	1.000	1.000	1.000	0.8864
	1.000	1.000	1.000	1.000	1.000	0.215	0.215	0.521	0.001	1.000	1.000	1.000	1.000	1.000	1.000	0.2147
LISTENER 17	1.000	1.000	1.000	1.000	1.000	0.735	0.735	1.000	1.000	1.000	1.000	1.000	1.000	1.000	1.000	0.9894
	1.000	1.000	1.000	1.000	1.000	0.657	0.657	0.933	0.911	1.000	1.000	1.000	1.000	1.000	1.000	0.6710
	1.000	1.000	1.000	1.000	1.000	0.477	0.477	0.646	0.979	1.000	1.000	1.000	1.000	1.000	1.000	0.8018
	1.000	1.000	1.000	1.000	1.000	0.566	0.566	0.938	1.000	1.000	1.000	1.000	1.000	1.000	1.000	0.5873
LISTENER 18	1.000	1.000	1.000	1.000	1.000	0.887	0.887	1.000	1.000	1.000	1.000	1.000	1.000	1.000	1.000	0.9955
	1.000	1.000	1.000	1.000	1.000	0.888	0.888	1.000	1.000	1.000	1.000	1.000	1.000	1.000	1.000	0.8933
	1.000	1.000	1.000	1.000	1.000	0.632	0.632	0.909	1.000	1.000	1.000	1.000	1.000	1.000	1.000	0.9489
	1.000	1.000	1.000	1.000	1.000	0.754	0.754	1.000	1.000	1.000	1.000	1.000	1.000	1.000	1.000	0.7664
LISTENER 19	1.000	1.000	1.000	1.000	1.000	0.487	0.487	0.867	0.004	1.000	1.000	1.000	1.000	1.000	1.000	0.7239
	1.000	1.000	1.000	1.000	1.000	0.617	0.617	0.891	0.804	1.000	1.000	1.000	1.000	1.000	1.000	0.6304
	1.000	1.000	1.000	1.000	1.000	0.520	0.520	0.733	1.000	1.000	1.000	1.000	1.000	1.000	1.000	0.8504
	1.000	1.000	1.000	1.000	1.000	0.269	0.269	0.572	0.413	1.000	1.000	1.000	1.000	1.000	1.000	0.2820
LISTENER 20	1.000	1.000	1.000	1.000	1.000	0.905	0.905	1.000	1.000	1.000	1.000	1.000	1.000	1.000	1.000	0.9962
	1.000	1.000	1.000	1.000	1.000	0.905	0.905	1.000	1.000	1.000	1.000	1.000	1.000	1.000	1.000	0.9096
	1.000	1.000	1.000	1.000	1.000	0.779	0.779	1.000	1.000	1.000	1.000	1.000	1.000	1.000	1.000	1.0000
	1.000	1.000	1.000	1.000	1.000	0.724	0.724	1.000	1.000	1.000	1.000	1.000	1.000	1.000	1.000	0.7379

TABLE M.5. (Cont.)

LISTENER 21	1.000	0.852	1.000	1.000	1.000	1.000	1.000	1.000	0.9941
	1.000	1.000	1.000	1.000	1.000	1.000	1.000	1.000	0.8170
	1.000	1.000	1.000	1.000	1.000	1.000	1.000	1.000	0.8272
	1.000	1.000	1.000	1.000	1.000	1.000	1.000	1.000	0.7205
LISTENER 22	1.000	0.789	1.000	1.000	1.000	1.000	1.000	1.000	0.9916
	1.000	1.000	1.000	1.000	1.000	1.000	1.000	1.000	0.8008
	1.000	1.000	1.000	1.000	1.000	1.000	1.000	1.000	0.7322
	1.000	1.000	1.000	1.000	1.000	1.000	1.000	1.000	0.6459
LISTENER 23	1.000	0.829	1.000	1.000	1.000	1.000	1.000	1.000	0.9932
	1.000	1.000	1.000	1.000	1.000	1.000	1.000	1.000	0.6935
	1.000	1.000	1.000	1.000	1.000	1.000	1.000	1.000	0.6824
	1.000	1.000	1.000	1.000	1.000	1.000	1.000	1.000	0.6925
LISTENER 24	1.000	0.798	1.000	1.000	1.000	1.000	1.000	1.000	0.9919
	1.000	1.000	1.000	1.000	1.000	1.000	1.000	1.000	0.8138
	1.000	1.000	1.000	1.000	1.000	1.000	1.000	1.000	0.9550
	1.000	1.000	1.000	1.000	1.000	1.000	1.000	1.000	0.6564
LISTENER 25	1.000	0.764	1.000	1.000	1.000	1.000	1.000	1.000	0.9906
	1.000	1.000	1.000	1.000	1.000	1.000	1.000	1.000	0.7118
	1.000	1.000	1.000	1.000	1.000	1.000	1.000	1.000	0.8500
	1.000	1.000	1.000	1.000	1.000	1.000	1.000	1.000	0.6181
LISTENER 26	1.000	0.797	1.000	1.000	1.000	1.000	1.000	1.000	0.9919
	1.000	1.000	1.000	1.000	1.000	1.000	1.000	1.000	0.5604
	1.000	1.000	1.000	1.000	1.000	1.000	1.000	1.000	0.7202
	1.000	1.000	1.000	1.000	1.000	1.000	1.000	1.000	0.6547
LISTENER 27	1.000	0.893	1.000	1.000	1.000	1.000	1.000	1.000	0.9957
	1.000	1.000	1.000	1.000	1.000	1.000	1.000	1.000	0.8989
	1.000	1.000	1.000	1.000	1.000	1.000	1.000	1.000	0.9821
	1.000	1.000	1.000	1.000	1.000	1.000	1.000	1.000	0.7743
LISTENER 28	1.000	0.790	1.000	1.000	1.000	1.000	1.000	1.000	0.9916
	1.000	1.000	1.000	1.000	1.000	1.000	1.000	1.000	0.8370
	1.000	1.000	1.000	1.000	1.000	1.000	1.000	1.000	0.9704
	1.000	1.000	1.000	1.000	1.000	1.000	1.000	1.000	0.6469
LISTENER 29	1.000	0.744	1.000	1.000	1.000	1.000	1.000	1.000	0.9898
	1.000	1.000	1.000	1.000	1.000	1.000	1.000	1.000	0.7688
	1.000	1.000	1.000	1.000	1.000	1.000	1.000	1.000	0.7952
	1.000	1.000	1.000	1.000	1.000	1.000	1.000	1.000	0.6083
LISTENER 30	1.000	0.646	0.978	0.889	1.000	1.000	1.000	1.000	0.9560
	1.000	1.000	1.000	1.000	1.000	1.000	1.000	1.000	0.6453
	1.000	1.000	1.000	1.000	1.000	1.000	1.000	1.000	0.7714
	1.000	1.000	1.000	1.000	1.000	1.000	1.000	1.000	0.5000

TABLE M.5. (Cont.)

LISTENER 31	1.000	1.000	1.000	1.000	0.694	0.992	0.993	1.000	1.000	1.000	1.000	1.000	1.000	0.9846
	1.000	1.000	1.000	1.000	0.850	1.000	1.000	1.000	1.000	1.000	1.000	1.000	1.000	0.8577
	1.000	1.000	1.000	1.000	0.702	0.966	1.000	1.000	1.000	1.000	1.000	1.000	1.000	0.9810
	1.000	1.000	1.000	1.000	0.456	0.831	0.940	1.000	1.000	1.000	1.000	1.000	1.000	0.4809
LISTENER 32	1.000	1.000	1.000	1.000	0.523	0.904	0.409	1.000	1.000	1.000	1.000	1.000	1.000	0.8258
	1.000	1.000	1.000	1.000	0.313	0.312	0.000	1.000	1.000	1.000	1.000	1.000	1.000	0.3174
	1.000	1.000	1.000	1.000	0.100	0.071	0.000	1.000	1.000	1.000	1.000	1.000	1.000	0.4796
	1.000	1.000	1.000	1.000	0.344	0.662	0.679	1.000	1.000	1.000	1.000	1.000	1.000	0.3642
LISTENER 33	1.000	1.000	1.000	1.000	0.419	0.779	0.000	1.000	1.000	1.000	1.000	1.000	1.000	0.7026
	1.000	1.000	1.000	1.000	0.378	0.435	0.000	1.000	1.000	1.000	1.000	1.000	1.000	0.3788
	1.000	1.000	1.000	1.000	0.129	0.090	0.000	1.000	1.000	1.000	1.000	1.000	1.000	0.4901
	1.000	1.000	1.000	1.000	0.190	0.498	0.000	1.000	1.000	1.000	1.000	1.000	1.000	0.1908
LISTENER 34	1.000	1.000	1.000	1.000	0.660	0.982	0.918	1.000	1.000	1.000	1.000	1.000	1.000	0.9640
	1.000	1.000	1.000	1.000	0.811	1.000	1.000	1.000	1.000	1.000	1.000	1.000	1.000	0.8204
	1.000	1.000	1.000	1.000	0.651	0.928	1.000	1.000	1.000	1.000	1.000	1.000	1.000	0.9597
	1.000	1.000	1.000	1.000	0.488	0.869	0.996	1.000	1.000	1.000	1.000	1.000	1.000	0.5134
LISTENER 35	1.000	1.000	1.000	1.000	0.551	0.928	0.533	1.000	1.000	1.000	1.000	1.000	1.000	0.8602
	1.000	1.000	1.000	1.000	0.799	1.000	1.000	1.000	1.000	1.000	1.000	1.000	1.000	0.8088
	1.000	1.000	1.000	1.000	0.636	0.913	1.000	1.000	1.000	1.000	1.000	1.000	1.000	0.9511
	1.000	1.000	1.000	1.000	0.332	0.640	0.635	1.000	1.000	1.000	1.000	1.000	1.000	0.3504
LISTENER 36	1.000	1.000	1.000	1.000	0.893	1.000	1.000	1.000	1.000	1.000	1.000	1.000	1.000	0.9957
	1.000	1.000	1.000	1.000	0.854	1.000	1.000	1.000	1.000	1.000	1.000	1.000	1.000	0.8615
	1.000	1.000	1.000	1.000	0.705	0.968	1.000	1.000	1.000	1.000	1.000	1.000	1.000	0.9819
	1.000	1.000	1.000	1.000	0.762	1.000	1.000	1.000	1.000	1.000	1.000	1.000	1.000	0.7738
LISTENER 37	1.000	1.000	1.000	1.000	0.641	0.976	0.875	1.000	1.000	1.000	1.000	1.000	1.000	0.9520
	1.000	1.000	1.000	1.000	0.645	0.922	0.886	1.000	1.000	1.000	1.000	1.000	1.000	0.6594
	1.000	1.000	1.000	1.000	0.391	0.463	0.818	1.000	1.000	1.000	1.000	1.000	1.000	0.6991
	1.000	1.000	1.000	1.000	0.469	0.847	0.955	1.000	1.000	1.000	1.000	1.000	1.000	0.4940
LISTENER 38	1.000	1.000	1.000	1.000	0.738	1.000	1.000	1.000	1.000	1.000	1.000	1.000	1.000	0.9895
	1.000	1.000	1.000	1.000	0.468	0.627	0.000	1.000	1.000	1.000	1.000	1.000	1.000	0.4643
	1.000	1.000	1.000	1.000	0.229	0.186	0.015	1.000	1.000	1.000	1.000	1.000	1.000	0.5444
	1.000	1.000	1.000	1.000	0.569	0.941	1.000	1.000	1.000	1.000	1.000	1.000	1.000	0.5909
LISTENER 39	1.000	1.000	1.000	1.000	0.786	1.000	1.000	1.000	1.000	1.000	1.000	1.000	1.000	0.9915
	1.000	1.000	1.000	1.000	0.729	0.981	1.000	1.000	1.000	1.000	1.000	1.000	1.000	0.7425
	1.000	1.000	1.000	1.000	0.554	0.797	1.000	1.000	1.000	1.000	1.000	1.000	1.000	0.8863
	1.000	1.000	1.000	1.000	0.624	0.970	1.000	1.000	1.000	1.000	1.000	1.000	1.000	0.6429
LISTENER 40	1.000	1.000	1.000	1.000	0.530	0.910	0.439	1.000	1.000	1.000	1.000	1.000	1.000	0.8341
	1.000	1.000	1.000	1.000	0.670	0.945	0.937	1.000	1.000	1.000	1.000	1.000	1.000	0.6849
	1.000	1.000	1.000	1.000	0.619	0.893	1.000	1.000	1.000	1.000	1.000	1.000	1.000	0.9400
	1.000	1.000	1.000	1.000	0.301	0.602	0.526	1.000	1.000	1.000	1.000	1.000	1.000	0.3167

TABLE M.5. (Cont.)

LISTENER 41								
0.751	1.000	0.253	0.557	0.000	1.000	1.000	1.000	0.6018
1.000	1.000	0.588	0.852	0.695	1.000	1.000	1.000	0.5998
1.000	1.000	0.382	0.443	0.793	1.000	1.000	1.000	0.6882
0.836	1.000	0.000	0.236	0.000	1.000	1.000	1.000	0.0100
LISTENER 42								
1.000	1.000	0.713	1.000	1.000	1.000	1.000	1.000	0.9885
1.000	1.000	0.771	1.000	1.000	1.000	1.000	1.000	0.7824
1.000	1.000	0.603	0.872	1.000	1.000	1.000	1.000	0.9283
1.000	1.000	0.279	0.581	0.448	1.000	1.000	1.000	0.2930
LISTENER 43								
1.000	1.000	0.796	1.000	1.000	1.000	1.000	1.000	0.9918
1.000	1.000	0.853	1.000	1.000	1.000	1.000	1.000	0.8606
1.000	1.000	0.706	0.968	1.000	1.000	1.000	1.000	0.9823
1.000	1.000	0.635	0.974	1.000	1.000	1.000	1.000	0.6534
LISTENER 44								
1.000	1.000	0.523	0.904	0.408	1.000	1.000	1.000	0.8256
1.000	1.000	0.780	1.000	1.000	1.000	1.000	1.000	0.7908
1.000	1.000	0.483	0.659	0.991	1.000	1.000	1.000	0.8088
1.000	1.000	0.615	0.966	1.000	1.000	1.000	1.000	0.6339
LISTENER 45								
1.000	1.000	0.717	1.000	1.000	1.000	1.000	1.000	0.9886
1.000	1.000	0.822	1.000	1.000	1.000	1.000	1.000	0.8314
1.000	1.000	0.539	0.769	1.000	1.000	1.000	1.000	0.8705
1.000	1.000	0.667	0.984	1.000	1.000	1.000	1.000	0.6835
LISTENER 46								
1.000	1.000	0.790	1.000	1.000	1.000	1.000	1.000	0.9916
1.000	1.000	0.822	1.000	1.000	1.000	1.000	1.000	0.8314
1.000	1.000	0.527	0.746	1.000	1.000	1.000	1.000	0.8580
1.000	1.000	0.667	0.984	1.000	1.000	1.000	1.000	0.6835
LISTENER 47								
1.000	1.000	0.763	1.000	1.000	1.000	1.000	1.000	0.9905
1.000	1.000	0.765	1.000	1.000	1.000	1.000	1.000	0.7765
1.000	1.000	0.267	0.238	0.407	1.000	1.000	1.000	0.5731
1.000	1.000	0.597	0.957	1.000	1.000	1.000	1.000	0.6172
LISTENER 48								
1.000	1.000	0.635	0.974	0.859	1.000	1.000	1.000	0.9478
1.000	1.000	0.639	0.916	0.871	1.000	1.000	1.000	0.6537
1.000	1.000	0.262	0.230	0.390	1.000	1.000	1.000	0.5690
1.000	1.000	0.464	0.840	0.949	1.000	1.000	1.000	0.4885
LISTENER 49								
1.000	1.000	0.729	1.000	1.000	1.000	1.000	1.000	0.9891
1.000	1.000	0.591	0.855	0.704	1.000	1.000	1.000	0.6022
1.000	1.000	0.383	0.446	0.796	1.000	1.000	1.000	0.6896
1.000	1.000	0.559	0.934	1.000	1.000	1.000	1.000	0.5810
LISTENER 50								
1.000	1.000	0.846	1.000	1.000	1.000	1.000	1.000	0.9939
1.000	1.000	0.887	1.000	1.000	1.000	1.000	1.000	0.8924
1.000	1.000	0.752	1.000	1.000	1.000	1.000	1.000	0.9997
1.000	1.000	0.631	0.973	1.000	1.000	1.000	1.000	0.6496

RURAL; URBAN POPULATIONS ? 146454, 110928

PTUR	PTURB	PTALL
0.931	0.979	0.951
0.701	0.800	0.744
0.776	0.908	0.833
0.527	0.629	0.571

APPENDIX N: RANDOM SELECTION OF POPULATION-WEIGHTED LISTENING POINTS AT THE ZION SITE

The objective of the listener-site-selection process was to identify 50 randomly selected building locations within the EPZ surrounding the Zion Nuclear Plant. These locations are assumed to be residential locations and are called "listener sites."

The various steps used in the site selection procedure are described below:

1. A population-distribution map (see Fig. N-1) consisting of a 10-mile-radius circle divided into annular sectors defined by interior circles and radii, was superimposed on topographical maps of the EPZ. Population distribution information consisted of the number of people within each annular sector. These data were used in order to population-weight the random selection process described below.
2. Each annular sector was first assigned a designator, ranging between A-1 and R-6 (see Fig. N-1). A range of numbers was then assigned to each sector according to the population in that sector. For example, Sector A-1, just north of the site, has a population of 99 and was assigned numbers 1 through 99. Sectors B-1 through L-1 (moving clockwise over Lake Michigan) have zero population and thus were not assigned any numbers. Sector M-1 has a population of 204 and was assigned numbers 100 to 303. Sector N-1 has a population of 440 and was assigned numbers 304 through 743. This process was continued until each number between 1 and 301,830 (the total estimated population) was assigned to a particular sector. A random number generator (avail-

able on a Texas Instruments Model TI-59 hand calculator, for example) was then used to select 50 numbers at random between 1 and 301,830. Each number selected represented one site (to be chosen later) within the sector containing that number. Thus, sectors with larger populations had a greater possibility of including chosen listener sites.

3. Having determined the sector locations of each potential listener site, the next step in the procedure involved selecting the actual sites within the respective sectors. This was accomplished by first over-laying a rectangular coordinate grid on each sector of interest on the topographic map. The grid was composed of boxes with dimensions of approximately 1000 feet square, and each box was assigned an X and a Y coordinate according to its location on the grid. The grid was positioned such that the X-axis was oriented in the east-west direction and the Y-axis was oriented in the north-south direction, and such that all parts of the sector of interest were covered by a positive (X,Y) coordinate pair box. A random number generator was then used to select random pairs of numbers within the X and Y ranges covering the sector of interest. Each X,Y pair was used to select a particular 1000 feet square box on the map. If there were buildings within the box, one of them was arbitrarily chosen as a listener site. If there were no buildings inside the box or if the box fell outside of the sector of interest, that coordinate pair was disregarded and another pair was chosen at random.

For urban sites in the pink "building-extension" area of the topographic map a residential building was always assumed to exist, and was selected at the center of the pink area in the 1000 feet square box.

4. The above process was repeated until 50 listener sites were randomly chosen. It was found, however, that some of the chosen sites did not properly reflect the population distribution in the EPZ. Therefore, the selection process was continued until this condition was rectified. In particular, six new urban sites were randomly chosen within the city of Kenosha, Wisconsin to replace the six sites chosen within the Great Lakes Naval Training Center, which has its own warning system. In addition, the EPZ was assumed to extend about 3 miles north of the 10 mile circle for the purposes of listener site selection, so as to include the entire city of Kenosha. As a result, four of the sample listener sites are located beyond the 10 mile circle in Kenosha. (This was done in response to a request by representatives of the city of Kenosha, since Kenosha has an existing emergency siren system throughout the city that will make up part of the warning system for Zion.)

The above procedure resulted in a pseudo-random sample of 50 specific listener locations, distributed throughout the EPZ as shown roughly on Fig. N-1.

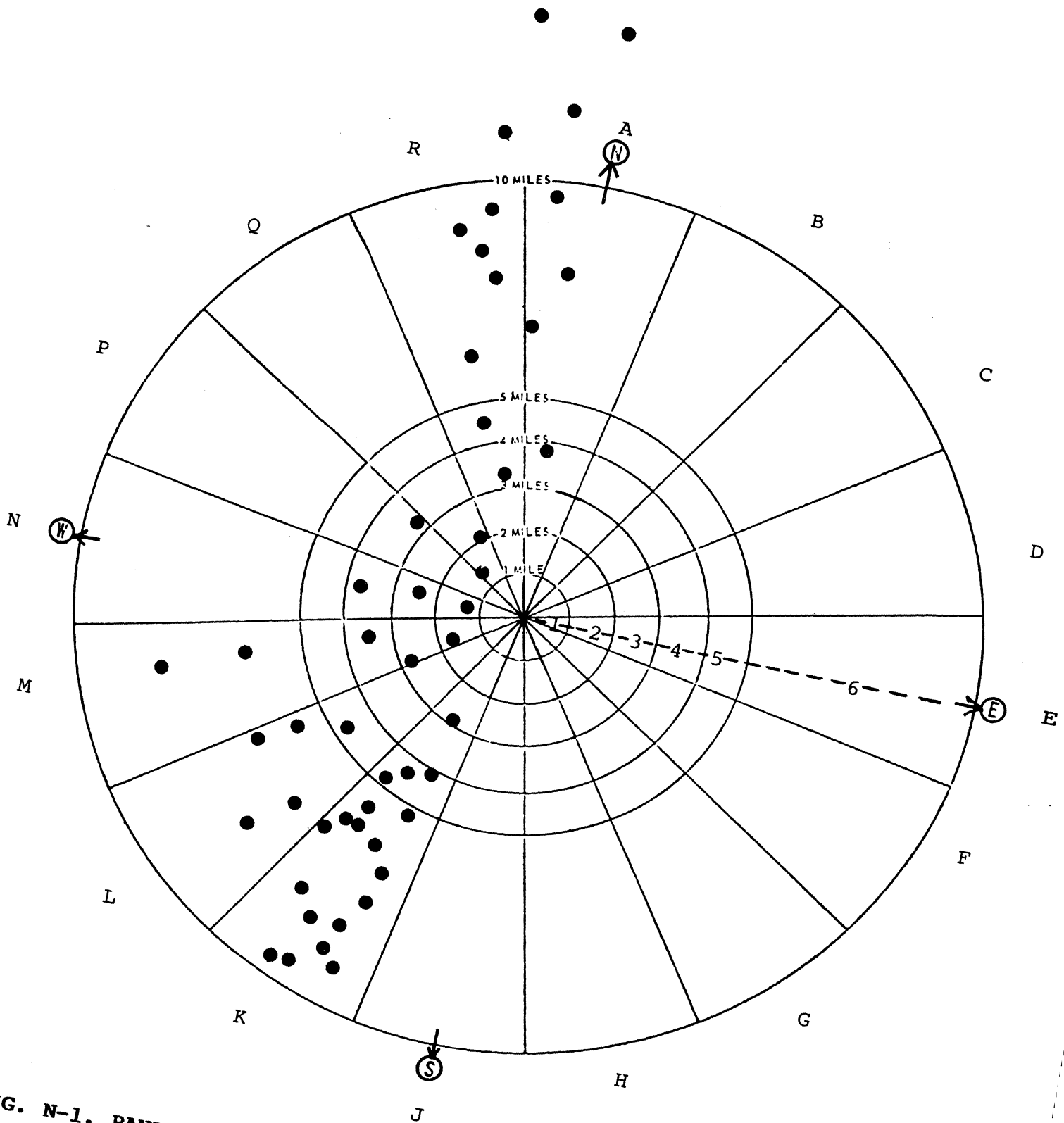

FIG. N-1. RANDOMLY SELECTED LISTENER SITES (APPROX.) AT THE ZION SITE.

APPENDIX O: SAMPLE SCENARIOS FOR THE EVALUATION OF SIREN ALERTING AT ZION.

Scenario	①	②	③	④
Season	Summer	Summer	Winter	Winter
Time of Day	Weekday Afternoon (7/11/80 @ 1500)	Late Night (7/17/80 @ 0200)	Weekday Evening(Rush 1/30/80 hr) @ 1800)	Late Night (1/7/80 @ 0200)
General Weather	Warm, Clear to Partly Cloudy	Warm, Clear to Partly Cloudy	Cold, Over- cast, Light Precipita- tion	Windy
Home/Vehicle Windows	Open	Open	Closed (& Storms)	Closed (& Storms)
Temperature, °F @35'	71°	70°	17°	13°
Dew Point °F @35'	62°	61°	16°	7.4°
Temperature Difference °F (meas. heights = 125' & 35')	-1.3°	+1.1°	-0.7°	-0.8°
Wind Direction:				
General	130°	290°	328°	251°
Wind Speed, mph (meas. height 125')	11.1	11.7	10.8	33
(meas. height = 35')	6.9	6.1	7.9	22
Percent of People Located				
Outdoors	20%	-	5%	-
In Motor Vehicles	6	1%	25	-
Indoors at Work:				
Commercial	23	3	-	4%
Industrial	7	1	-	1
In Home-Sleeping	4	95	-	95
In Home-Radio/TV	20	-	14	-
In Home-Noisy	-	-	3	-
In Home-Active	6	-	35	-
In Home-Isolated	4	-	14	-
In Home-Quiet	10	-	4	-

APPENDIX P: SIREN LOCATIONS FOR THE ZION EPZ

This appendix provides existing and proposed siren locations for the Zion EPZ as of 15 October 1981. Siren locations are provided on a set of topographical maps (Figs. P-2 through P-6). Figure P-1 shows the relationship of the individual maps to the Zion EPZ.

A total of 66 sirens are employed, 39 of which are existing and 27 of which are proposed. The proposed sirens are identified using Commonwealth Edison (CE) or Wisconsin Electric (WE) prefixes. Existing sirens have been numbered arbitrarily, using the prefix "I" for those located in Illinois and "W" for those located in Wisconsin. Table P.1 provides information on the type, rating, mounting height and status of each siren, as well as a guide for locating the sirens on the topographical maps.

TABLE P.1. ZION SIREN INFORMATION

Siren No.	Type	Rated SPL (dBC @ 100 ft.)	Approx. Mounting Height (ft)	Status	Location (Map Figure No.)
CE-1	Stationary	115	55	Proposed	B-6
CE-2	Stationary	115	55	Proposed	B-5
CE-3	Rotating	123	55	Proposed	B-5
CE-4	Stationary	115	55	Proposed	B-5
CE-5	Rotating	126	55	Proposed	B-5
CE-6	Rotating	123	55	Proposed	B-3
CE-7A	Rotating	126	55	Proposed	B-4
CE-8B	Rotating	126	55	Proposed	B-4
CE-9	Rotating	126	55	Proposed	B-4
CE-10	Rotating	126	55	Proposed	B-4
CE-11	Rotating	124	55	Proposed	B-4
CE-12	Rotating	124	55	Proposed	B-4
CE-13	Rotating	123	55	Proposed	B-4
CE-14	Rotating	126	55	Proposed	B-4
CE-15	Rotating	124	55	Proposed	B-4
CE-16A	Rotating	126	55	Proposed	B-4
CE-17	Rotating	126	55	Proposed	B-4
CE-18	Rotating	126	55	Proposed	B-4
CE-19	Rotating	123	55	Proposed	B-4
CE-20	Stationary	115	55	Proposed	B-4
CE-21	Stationary	115	55	Proposed	B-4

TABLE P.1. ZION SIREN INFORMATION (Cont.)

Siren No.	Type	Rated SPL (dBC @ 100 ft.)	Approx. Mounting Height (ft)	Status	Location (Map Figure No.)
WE-1	Rotating	126	55	Proposed	B-2
WE-2	Stationary	115	55	Proposed	B-2
WE-3	Stationary	115	55	Proposed	B-2
WE-4	Rotating	124	55	Proposed	B-2
WE-6	Rotating	124	55	Proposed	B-4
WE-7	Rotating	126	55	Proposed	B-4
I-1	Rotating	125	40	Existing	B-6
I-2	Rotating	125	40	Existing	B-6
I-3	Rotating	125	40	Existing	B-6
I-4	Rotating	125	40	Existing	B-6
I-5	Rotating	125	40	Existing	B-6
I-6	Rotating	125	40	Existing	B-6
I-7	Rotating	125	40	Existing	B-6
I-8	Rotating	125	40	Existing	B-6
I-9	Stationary	115	35	Existing	B-6
I-10	Rotating	125	50	Existing	B-6
I-11	Stationary	115	40	Existing	B-6
I-12	Stationary	115	30	Existing	B-6
I-13	Rotating	125	30	Existing	B-6
I-14	Stationary	115	40	Existing	B-6
I-15	Rotating	125	40	Existing	B-6
I-16	Stationary	115	35	Existing	B-6

TABLE P.1. ZION SIREN INFORMATION (Cont.)

Siren No.	Type	Rated SPL (dBC @ 100 ft.)	Approx. Mounting Height (ft)	Status	Location (Map Figure No.)
I-17	Rotating	125	40	Existing	B-6
I-18	Stationary	115	40	Existing	B-6
I-19	Stationary	115	40	Existing	B-6
I-20	Rotating	125	25	Existing	B-4
I-21	Stationary	115	40	Existsing	B-4
I-22	Stationary	115	40	Existing	B-4
I-23	Stationary	115	25	Existing	B-4
W-1	Rotating	125	40	Existing	B-2
W-2	Rotating	125	50	Existing	B-2
W-3	Rotating	125	25	Existing	B-2
W-4	Rotating	125	50	Exiting	B-2
W-5	Rotating	125	40	Existing	B-2
W-6	Rotating	125	60	Existing	B-2
W-7	Stationary	100	40	Existing	B-2
W-8	Rotating	125	40	Existing	B-2
W-9	Rotating	125	60	Existing	B-2
W-10	Stationary	100	40	Existing	B-2
W-11	Rotating	125	60	Existing	B-2
W-12	Rotating	125	40	Existing	B-2
W-13	Rotating	125	50	Existing	B-2
W-14	Rotating	125	50	Existing	B-2
W-15	Rotating	125	40	Existing	B-2
W-16	Stationary	100	50	Existing	B-2

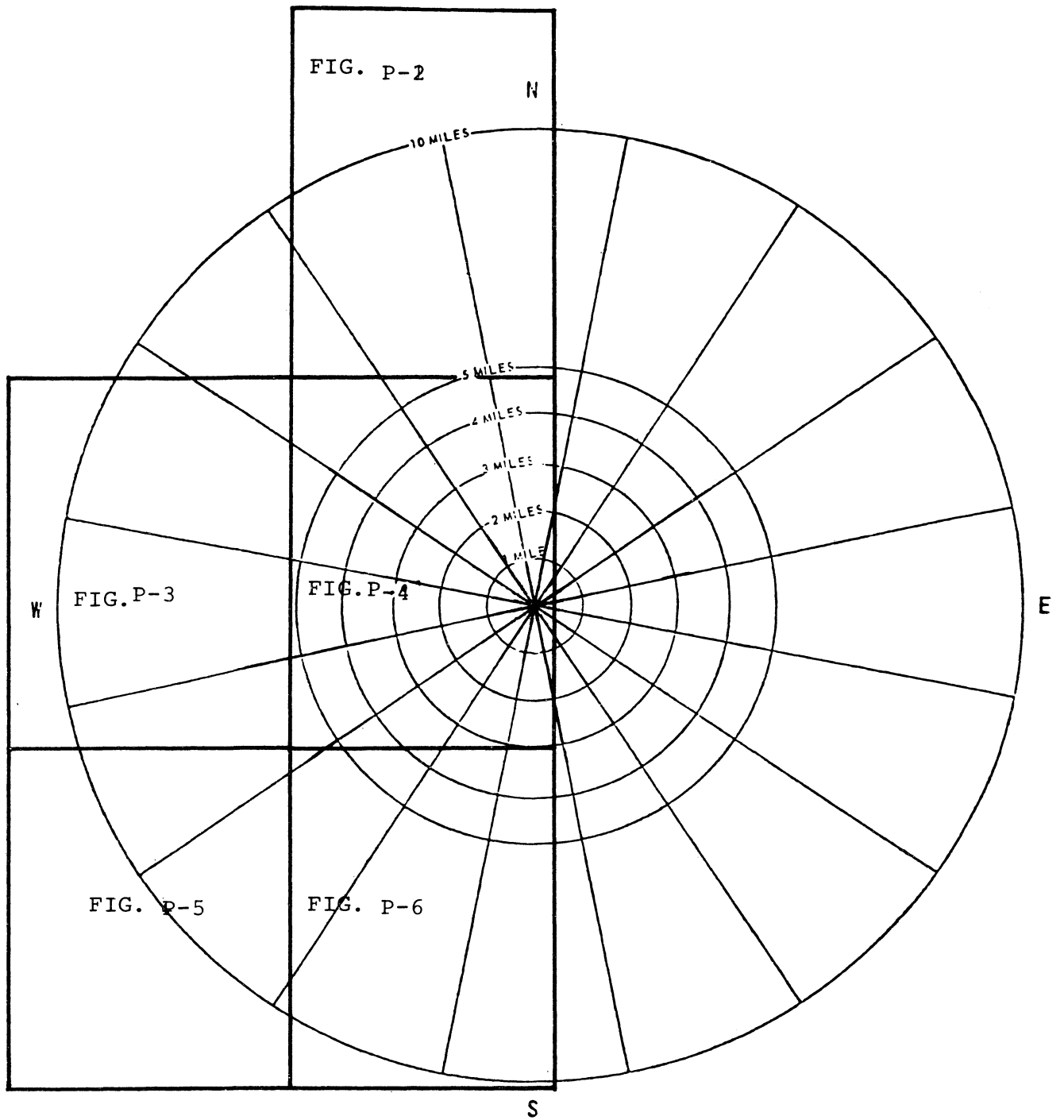

FIG. P-1. ZION SIREN MAP LOCATOR.

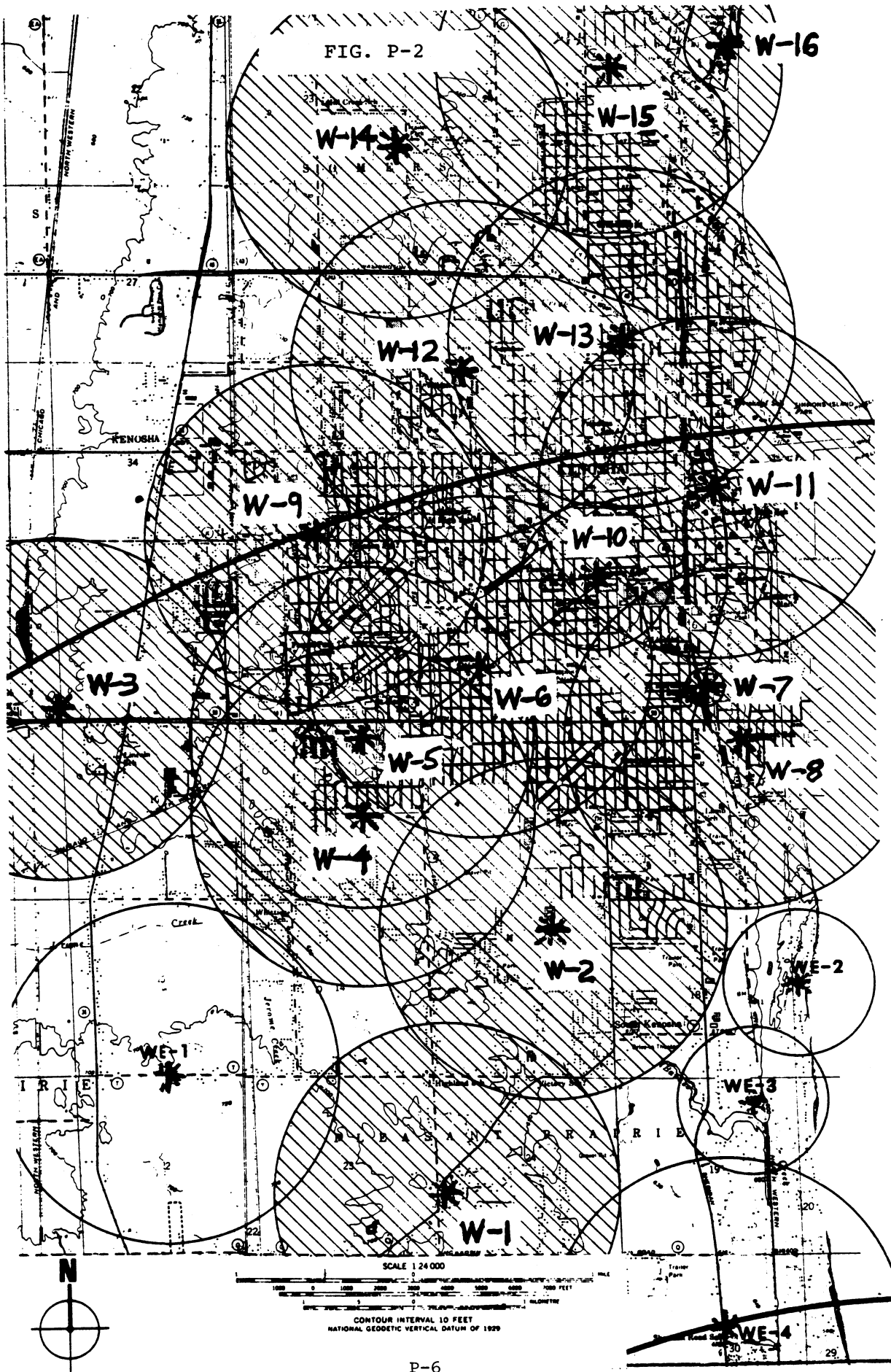

FIG. P-3

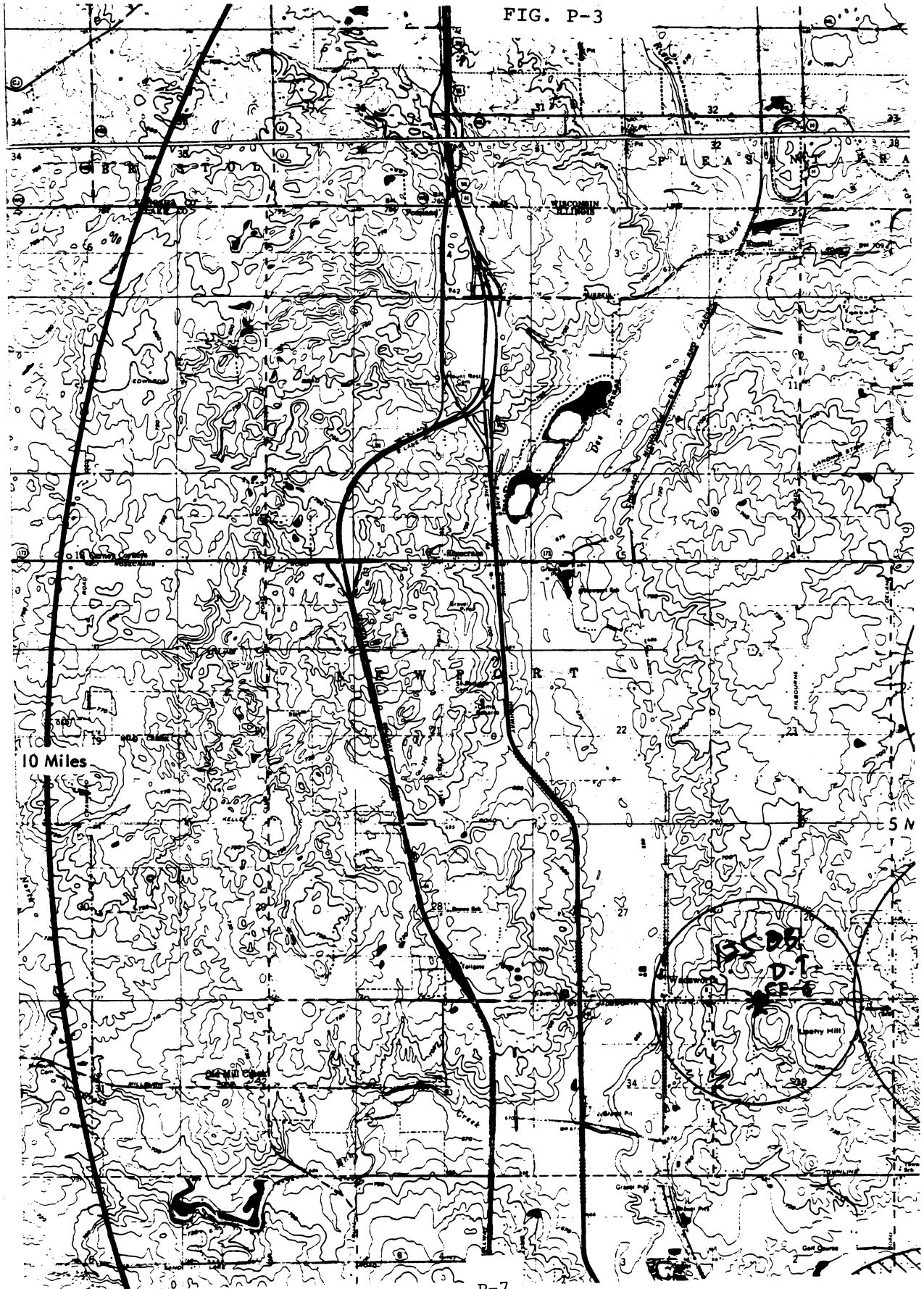
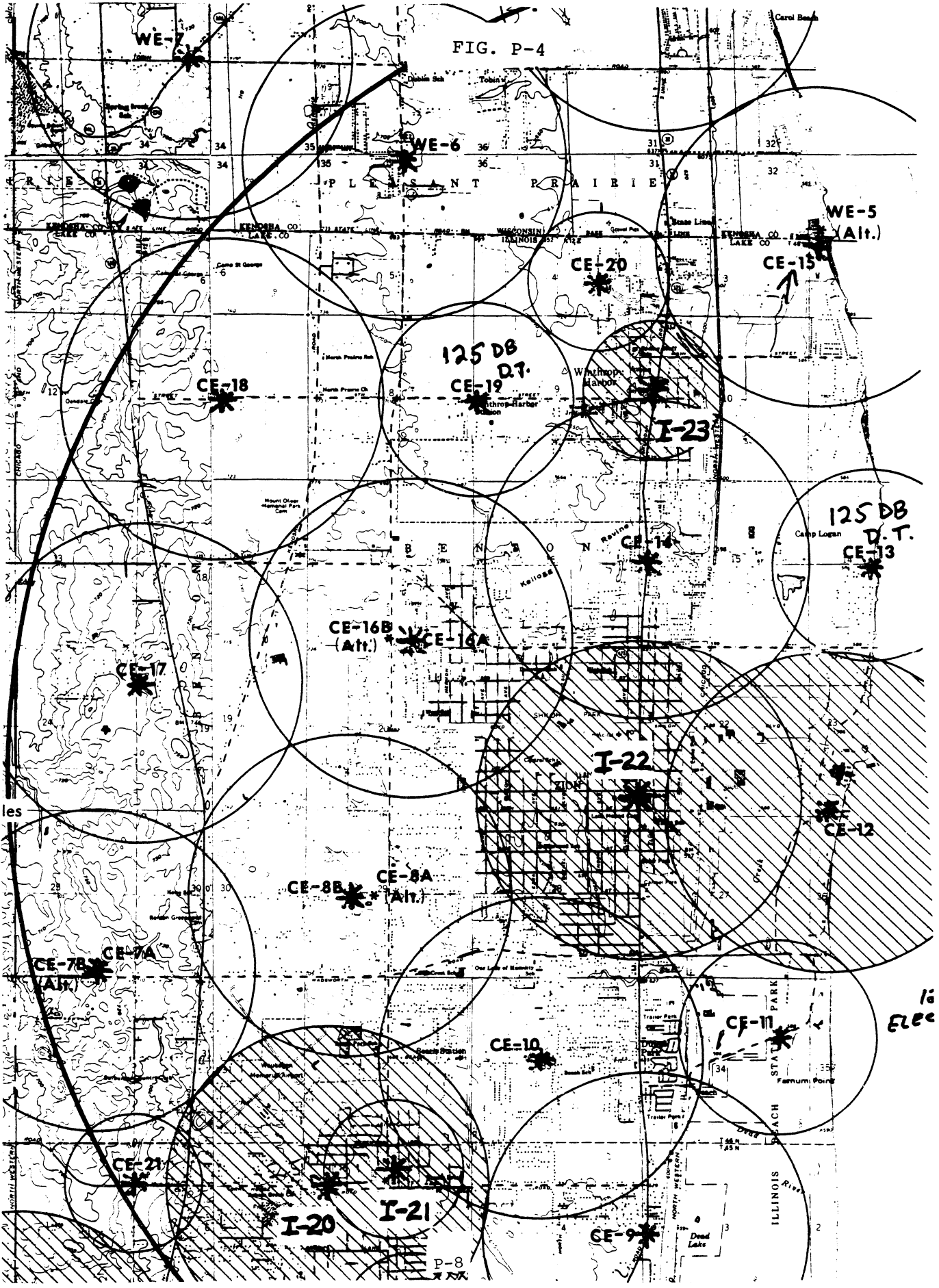

FIG. P-4



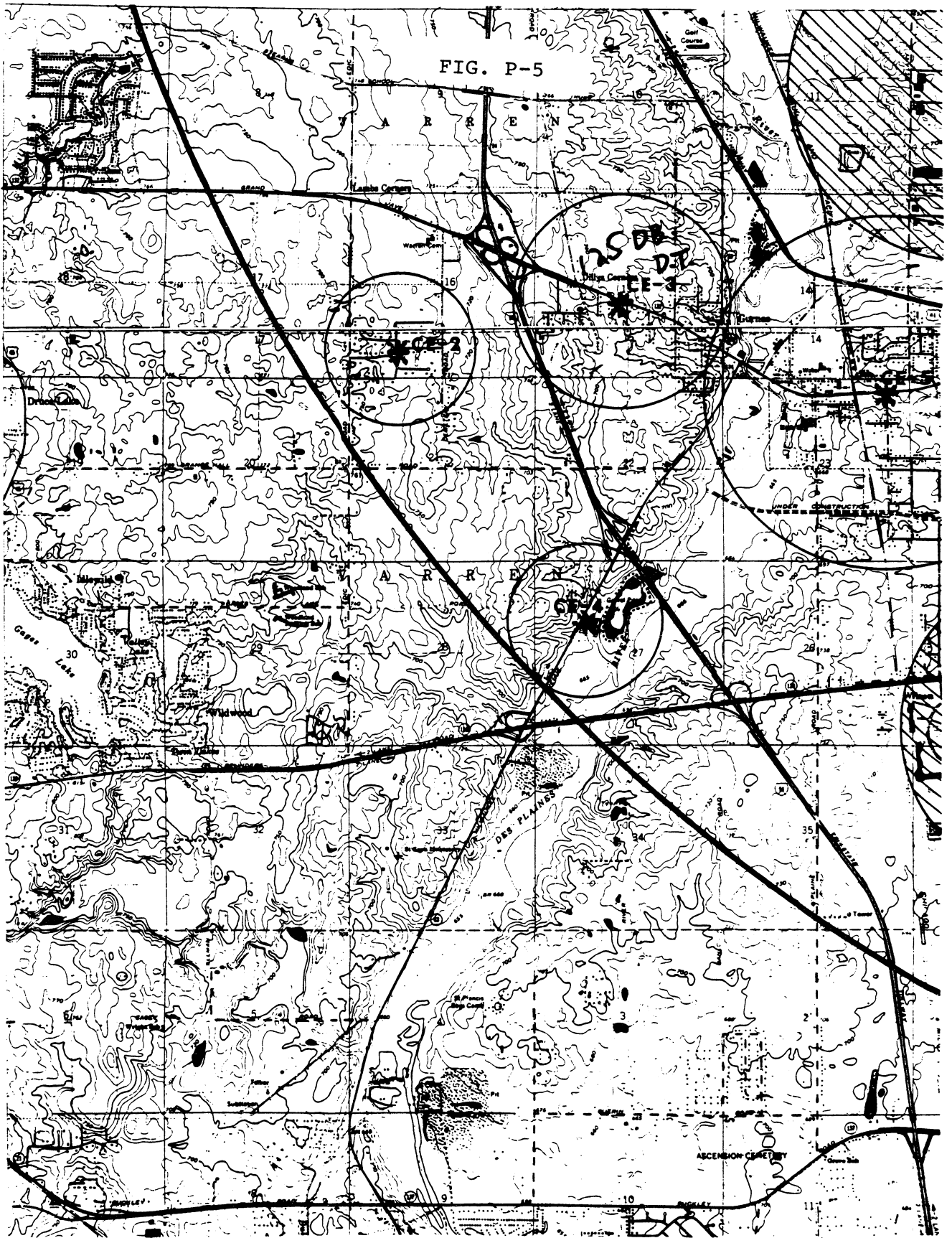
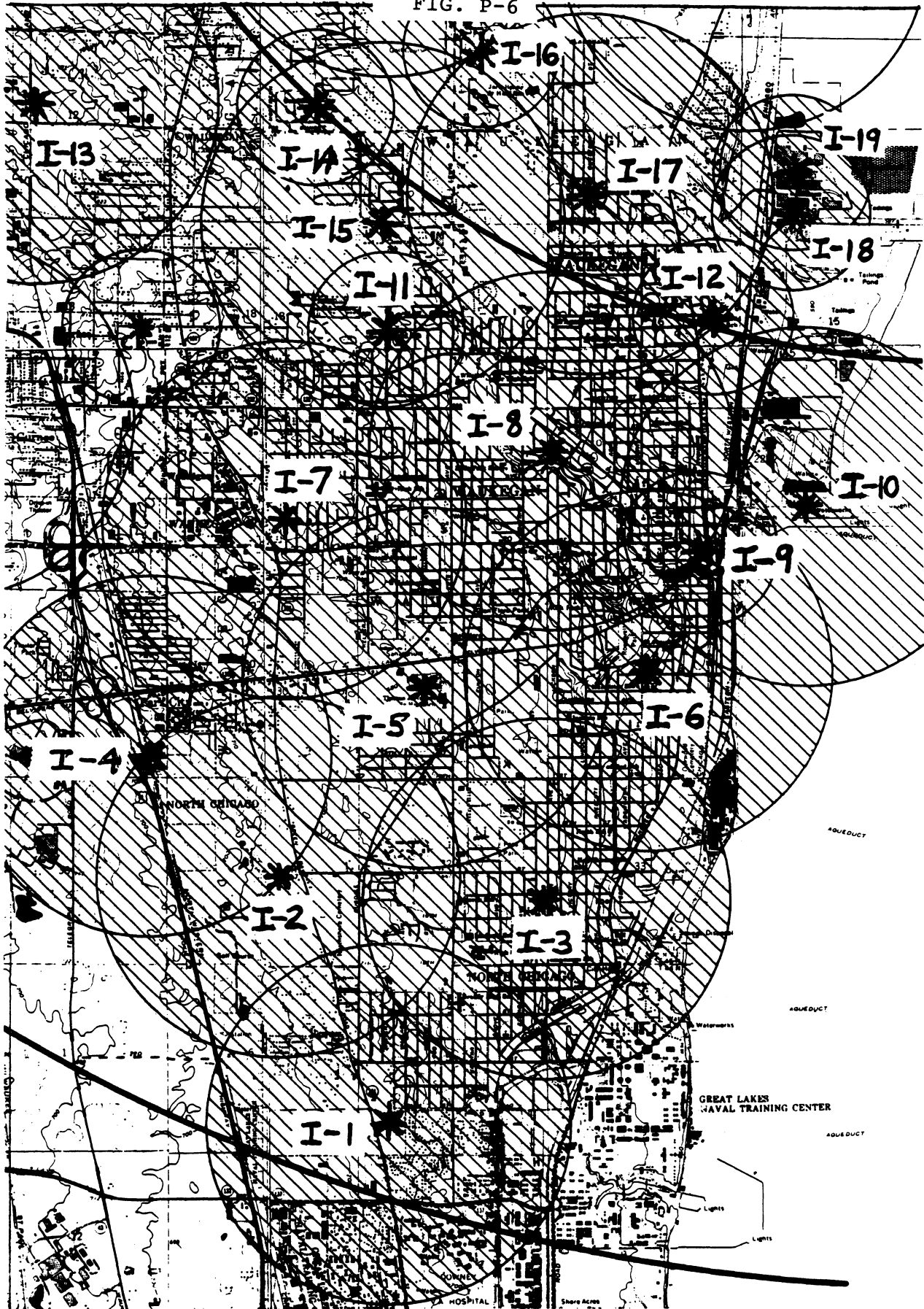

FIG. P-6



APPENDIX Q: ANALYSIS INPUT/OUTPUT DATA FOR ZION

This appendix provides listings of computer file input and output data for the Zion analysis. Explanation of the terminology used for each listing is provided below.

Table Q.1. ZIONSPEAKS

This file contains input data for each of the Zion sirens as follows:

- . Siren No. - number assigned to each siren for use by computer program.

- . Siren Name - first letter indicates whether the siren is rotating or stationary type (R or S); the remainder consists of the siren designation, beginning with a letter and ending with a number. For proposed sirens, the Commonwealth Edison designation is used. Existing sirens are arbitrarily designated, beginning with the letter I (for Illinois) or W (for Wisconsin).

- . x,y,z - these are the physical coordinates for the siren location; the x-axis is oriented east-west, the y-axis is oriented north-south, and the z-axis is oriented vertically. The x and y coordinates are in units of km, referenced to the grid shown on the

Table Q.1 (Continued)

Feb. 1981 NRC Emergency Planning Map for Zion (the plant center is located approximately at x=434.1, y=4699.4). The z coordinates are in units of feet

- . SPL@100FT - these numbers indicate the rated sound pressure level for each siren at a distance of 100 feet, in dB.

Table Q.2 ZIONLISTENS

This file contains input data for each of the randomly selected listener locations as follows:

- . Site No. - number assigned to each site for use by computer program.
- . Site Name - designator for listener site; the first letter indicates whether the site is urban or rural (U or R).
- . x,y,z - these are the physical coordinates for the listener location; the x-axis is oriented east-west, the y-axis is oriented north-south, and the z-axis is oriented vertically. The x and y coordinates are in units of km, referenced to the grid shown on the

Table Q.2 (Continued)

Feb. 1981 NRC Emergency Planning Map for Zion (the plant center is located approximately at $x=434.1$, $y=4699.4$). The z coordinates are in units of feet.

- . Rural Road - this column indicates whether rural listener sites are within 1000 ft of major highway (NEAR) or beyond 1000 ft (FAR). This information is required for the selection of appropriate outdoor background noise levels.

Table Q.3 ZIONSKY

This file contains input data for each of the four sample scenarios as follows:

- . Scenario No. - number assigned to each scenario (see Appendix N).
- . AMOL - molecular absorption, in dB/1000 feet.
- . WIND - wind direction in degrees (0° = wind from north, etc.)
- . NRES - residential building outdoor-to-indoor noise reduction, in dB.

Table Q.3 (Continued)

- . NCRM - commercial building outdoor-to-indoor noise reduction, in dB.
- . F1 - F8 - activity fractions.

F1 = fraction of people outdoors.

F2 = fraction of people indoors, at home, listening to radio or TV.

F3 = fraction of people indoors, at home, sleeping.

F4 = fraction of people indoors, at home, neither sleeping nor listening to radio or TV.

F5 = fraction of people indoors, at work, in commercial establishments.

F6 = fraction of people indoors, at work, in industrial locations.

F7 = fraction of people in vehicles in urban areas at 30 mph.

F8 = fraction of people in vehicles in rural areas at 55 mph.

Table Q.3 (Continued)

- . INP - indoor alert probability curve (see Fig. 5-4 of text).
- . PU30 - probability of alert for motorists in urban areas at 30 mph.
- . PR55 - probability of alert for motorists in rural areas at 55 mph.
- . MUL - vertical profile of wind speed, βz , in ft/sec/ln ft.
- . ADD - vertical profile of air temperature, a , in $^{\circ}\text{F}/\ln \text{ ft}$.

Table Q.4 LISTENEROUTPUT

This listing provides the number, name and outdoor sound pressure level (LOUT, in dB) for the "dominant" siren at each sample listener location, for each of the four sample scenarios. The results are listed in numerical order for scenarios one through four for each listener site.

Table Q.5 PROBS

This listing provides the final results for the analysis. Information is listed in numerical order for scenarios one through four for each listener site. This information consists of alert probabilities P1 through P8 corresponding to activity fractions F1 through F8, as well as the total probability of alert (PT) for each sample scenario at each sample listener site.

A summary is provided at the end of the listing showing the rural and urban population followed by the total rural probability of alert (PTRUR), the total urban probability of alert (PTURB), and the total (population-weighted) probability of alert for the EPZ (PTALL). The total probability values are listed in numerical order for sample scenarios one through four.

TABLE Q.1

ZIONLISTENS

SITE #		SITE NAME	X	Y	Z	RURAL ROAD
1	U	1	430.640	4719.860	640.000	-
2	U	2	432.600	4719.920	610.000	-
3	U	3	430.300	4716.500	630.000	-
4	U	4	432.100	4716.720	620.000	-
5	U	5	432.050	4714.950	620.000	-
6	U	6	430.300	4714.340	638.000	-
7	U	7	429.320	4713.720	665.000	-
8	U	8	430.180	4713.280	638.000	-
9	U	9	430.820	4712.660	631.000	-
10	U	10	433.060	4712.680	595.000	-
11	R	11	432.260	4710.100	615.000	NEAR
12	R	12	430.320	4708.960	675.000	NEAR
13	R	13	431.360	4706.160	640.000	FAR
14	R	14	433.600	4705.680	585.000	FAR
15	R	15	432.340	4704.460	625.000	NEAR
16	R	16	429.860	4702.300	700.000	FAR
17	R	17	432.140	4702.000	610.000	NEAR
18	U	18	432.240	4701.740	642.000	-
19	U	19	432.140	4699.540	640.000	-
20	U	20	430.570	4699.880	665.000	-
21	R	21	428.100	4699.580	725.000	NEAR
22	U	22	431.540	4697.940	655.000	-
23	R	23	430.220	4696.920	655.000	FAR
24	R	24	428.720	4697.940	715.000	FAR
25	R	25	424.400	4696.380	690.000	FAR
26	R	26	422.260	4695.800	705.000	NEAR
27	R	27	426.620	4694.140	700.000	FAR
28	R	28	425.560	4693.600	690.000	FAR
29	R	29	427.480	4691.560	725.000	NEAR
30	R	30	426.660	4690.620	705.000	NEAR
31	U	31	428.740	4694.240	705.000	-
32	R	32	432.200	4695.080	615.000	NEAR
33	U	33	431.840	4693.260	635.000	-
34	U	34	431.100	4693.080	660.000	-
35	U	35	430.420	4692.680	676.000	-
36	U	36	431.080	4691.480	655.000	-
37	U	37	429.500	4691.360	665.000	-
38	U	38	429.320	4690.740	670.000	-
39	U	39	428.900	4690.760	690.000	-
40	U	40	428.360	4690.360	725.000	-
41	U	41	430.500	4690.360	655.000	-
42	U	42	430.900	4689.420	685.000	-
43	U	43	430.580	4688.380	655.000	-
44	U	44	430.160	4687.360	655.000	-
45	R	45	428.980	4687.200	695.000	NEAR
46	R	46	428.060	4687.700	720.000	NEAR
47	U	47	429.960	4686.360	660.000	-
48	U	48	430.180	4685.780	655.000	-
49	U	49	429.000	4685.200	715.000	-
50	U	50	428.720	4685.140	725.000	-

TABLE Q.2

<u>ZIONSPEAKS</u>							
<u>SIREM#</u>	<u>SIREN</u>	<u>NHME</u>	<u>X</u>	<u>Y</u>	<u>Z</u>	<u>SPL@100 FT</u>	
1	S CE-1		426.960	4691.780	755.000	115	
2	S CE-2		421.120	4691.520	790.000	115	
3	R CE-3		429.060	4691.860	775.000	129	
4	S CE-4		422.700	4689.100	736.000	115	
5	R CE-5		425.940	4691.060	725.000	126	
6	R CE-6		424.480	4697.620	785.000	129	
7	R CE-7H		426.940	4697.620	775.000	126	
8	R CE-8B		429.320	4698.320	760.000	126	
9	R CE-9		432.200	4694.950	665.000	126	
10	R CE-10		431.140	4696.660	697.000	126	
11	R CE-11		433.420	4696.960	625.000	124	
12	R CE-12		433.890	4699.060	641.000	124	
13	R CE-13		434.370	4701.460	640.000	129	
14	R CE-14		432.220	4701.500	690.000	126	
15	R CE-15		433.680	4704.640	635.000	124	
16	R CE-16H		429.950	4700.780	745.000	126	
17	R CE-17		427.400	4700.420	775.000	126	
18	R CE-18		428.150	4703.120	795.000	126	
19	R CE-19		430.610	4703.140	735.000	129	
20	S CE-20		431.800	4704.340	705.000	115	
21	S CE-21		427.260	4695.520	745.000	115	
22	R ME-1		427.600	4709.640	755.000	126	
23	S ME-2		433.140	4710.380	650.000	115	
24	S ME-3		432.700	4709.320	665.000	115	
25	R ME-4		432.400	4707.280	680.000	124	
26	R ME-5		429.940	4705.440	755.000	126	
27	R ME-7		428.000	4706.400	775.000	126	
28	R 1-1		428.840	4684.840	760.000	126	
29	R 1-2		427.940	4687.040	750.000	125	
30	R 1-3		430.200	4686.300	695.000	125	

TABLE Q.2 (Continued)

31	R	1-4	426.940	4688.100	740.000	125
32	R	1-5	429.160	4688.620	705.000	125
33	R	1-6	431.140	4688.740	710.000	125
34	R	1-7	428.140	4690.100	765.000	125
35	R	1-8	430.370	4690.680	690.000	125
36	S	1-9	431.600	4689.780	670.000	115
37	R	1-10	432.500	4690.140	640.000	125
38	S	1-11	429.040	4691.780	700.000	115
39	S	1-12	431.780	4691.780	630.000	115
40	R	1-13	426.100	4693.700	740.000	125
41	S	1-14	428.380	4693.680	745.000	115
42	R	1-15	428.940	4692.680	725.000	125
43	S	1-16	429.780	4694.180	690.000	115
44	R	1-17	430.700	4692.880	700.000	125
45	S	1-18	432.440	4692.680	620.000	115
46	S	1-19	432.420	4693.040	620.000	115
47	R	1-20	429.060	4695.520	715.000	125
48	S	1-21	429.680	4695.640	715.000	115
49	S	1-22	432.060	4699.180	674.000	115
50	S	1-23	432.300	4703.160	660.000	115
51	R	0-1	429.960	4708.500	725.000	125
52	R	0-2	430.980	4710.960	675.000	125
53	R	0-3	426.680	4713.000	723.000	125
54	R	0-4	429.300	4711.940	705.000	125
55	R	0-5	429.300	4712.700	695.000	125
56	R	0-6	430.360	4713.340	690.000	125
57	S	0-7	432.360	4713.120	650.000	100
58	R	0-8	432.680	4712.580	655.000	125
59	R	0-9	428.940	4714.580	750.000	125
60	S	0-10	431.400	4714.140	663.000	100
61	R	0-11	432.500	4714.880	668.000	125
62	R	0-12	430.260	4716.040	690.000	125
63	R	0-13	431.700	4716.280	670.000	125
64	R	0-14	429.680	4718.060	700.000	125
65	R	0-15	431.640	4718.800	660.000	125
66	S	0-16	432.700	4718.940	660.000	100

TABLE Q.3

SCEN#	AMOL	WIND	MPES	RCRM	F1	F2	F3	F4	F5	F6	F7	F8
1	1.00	130	16.	31.	.200	.200	.040	.200	.230	.070	.053	.007
2	1.00	290	16.	31.	.000	.000	.950	.000	.030	.010	.009	.001
3	1.00	328	31.	31.	.050	.140	.000	.560	.000	.000	.223	.028
4	2.00	251	31.	31.	.000	.000	.950	.000	.040	.010	.000	.000

INF	PO30	PR55	MUL	ADD
1	1.000	1.000	4.870	-1.020
1	1.000	1.000	6.520	0.860
3	1.000	1.000	1.270	-0.550
1	1.000	1.000	12.650	-0.630

TABLE Q.4

PROBOUT

IS #	LISTENER NAME	SIREN #	SIREN NAME	LOUT
1	U 1	65	R W-15	86.6
		64	R W-14	81.7
		65	R W-15	86.6
		64	R W-14	75.0
2	U 2	66	S W-16	86.6
		65	R W-15	86.5
		65	R W-15	86.5
		65	R W-15	81.6
3	U 3	62	R W-12	99.9
		62	R W-12	94.9
		62	R W-12	89.9
		62	R W-12	98.4
4	U 4	63	R W-13	87.2
		63	R W-13	97.2
		63	R W-13	87.2
		63	R W-13	95.3
5	U 5	61	R W-11	100.0
		63	R W-13	87.4
		61	R W-11	95.0
		61	R W-11	78.5
6	U 6	56	R W-6	91.4
		59	R W-9	86.4
		59	R W-9	86.4
		56	R W-6	88.1
7	U 7	55	R W-5	91.2
		59	R W-9	92.1
		59	R W-9	92.1
		59	R W-9	89.0
8	U 8	56	R W-6	108.5
		56	R W-6	103.5
		56	R W-6	108.5
		56	R W-6	97.8
9	U 9	52	R W-2	84.4
		56	R W-6	93.7
		56	R W-6	93.7
		56	R W-6	91.0
10	U 10	58	R W-8	91.5
		58	R W-8	101.5
		58	R W-8	101.5
		58	R W-8	100.2

TABLE Q.4 (Continued)

11	R 11	24	S WE-3	82.7
		52	R W-2	85.9
		52	R W-2	85.9
		52	R W-2	80.8
12	R 12	51	R W-1	92.4
		51	R W-1	97.4
		51	R W-1	87.4
		51	R W-1	95.5
13	R 13	20	S CE-20	67.8
		26	R WE-6	86.2
		25	R WE-4	75.0
		26	R WE-6	81.0
14	R 14	15	R CE-15	88.4
		25	R WE-4	80.8
		25	R WE-4	80.8
		15	R CE-15	84.6
15	R 15	15	R CE-15	84.9
		20	S CE-20	88.0
		20	S CE-20	88.0
		20	S CE-20	86.2
16	R 16	16	R CE-16A	87.0
		18	R CE-18	83.7
		18	R CE-18	83.7
		16	R CE-16A	82.0
17	R 17	14	R CE-14	99.9
		14	R CE-14	89.9
		14	R CE-14	89.9
		14	R CE-14	98.3
18	U 18	14	R CE-14	107.2
		14	R CE-14	107.2
		14	R CE-14	107.2
		14	R CE-14	106.4
19	U 19	49	S I-22	92.1
		49	S I-22	92.1
		49	S I-22	87.1
		49	S I-22	90.9
20	U 20	49	S I-22	70.5
		16	R CE-16A	91.3
		16	R CE-16A	91.3
		16	R CE-16A	87.7

TABLE Q.4 (Continued)

21	R 21	8	R CE-8B	85.0
		17	R CE-17	91.3
		17	R CE-17	91.3
		17	R CE-17	87.7
22	U 22	10	R CE-10	88.7
		10	R CE-10	88.7
		49	S I-22	77.7
		10	R CE-10	84.3
23	R 23	10	R CE-10	92.9
		8	R CE-8B	85.8
		8	R CE-8B	85.8
		8	R CE-8B	80.3
24	R 24	8	R CE-8B	96.3
		7	R CE-7A	84.6
		8	R CE-8B	91.3
		7	R CE-7A	78.7
25	R 25	40	R I-13	74.2
		6	R CE-6	81.7
		6	R CE-6	81.7
		6	R CE-6	57.6
26	R 26	40	R I-13	67.5
		6	R CE-6	54.1
		6	R CE-6	54.1
		3	R CE-3	49.2
27	R 27	40	R I-13	80.8
		40	R I-13	95.8
		40	R I-13	85.8
		40	R I-13	93.5
28	R 28	40	R I-13	98.1
		40	R I-13	78.1
		40	R I-13	88.1
		40	R I-13	76.3
29	R 29	34	R I-7	85.3
		1	S CE-1	87.8
		1	S CE-1	87.8
		1	S CE-1	85.9
30	R 30	34	R I-7	85.6
		5	R CE-5	88.2
		5	R CE-5	88.2
		5	R CE-5	83.7

TABLE Q.4 (Continued)

31	U 31	41	S I-14	81.0
		41	S I-14	86.0
		47	R I-20	82.9
		41	S I-14	83.8
32	R 32	9	R CE-9	112.9
		9	R CE-9	112.9
		9	R CE-9	112.9
		9	R CE9	112.4
33	U 33	46	S I-19	86.8
		44	R I-17	89.1
		9	R CE-9	85.3
		44	R I-17	85.2
34	U 34	44	R I-17	90.2
		44	R I-17	100.2
		44	R I-17	100.2
		44	R I-17	98.7
35	U 35	44	R I-17	102.8
		44	R I-17	92.8
		44	R I-17	102.8
		44	R I-17	81.7
36	U 36	39	S I-12	84.5
		35	R I-8	90.6
		44	R I-17	86.7
		35	R I-8	87.1
37	U 37	35	R I-8	90.2
		38	S I-11	87.0
		38	S I-11	87.0
		38	S I-11	85.0
38	U 38	35	R I-8	90.8
		38	S I-11	80.7
		38	S I-11	80.7
		34	R I-7	77.3
39	U 39	35	R I-8	86.5
		34	R I-7	88.5
		38	S I-11	81.3
		34	R I-7	85.2
40	U 40	34	R I-7	102.9
		34	R I-7	102.9
		34	R I-7	102.9
		34	R I-7	101.8

TABLE Q.4 (Continued)

41	U 41	35	R I-8	87.8
		35	R I-8	102.8
		35	R I-8	102.8
		35	R I-8	101.6
42	U 42	33	R I-6	95.2
		35	R I-8	87.5
		35	R I-8	87.5
		35	R I-8	83.0
43	U 43	33	R I-6	96.0
		32	R I-5	86.8
		33	R I-6	91.0
		32	R I-5	82.1
44	U 44	30	R I-3	97.8
		30	R I-3	87.8
		30	R I-3	87.8
		30	R I-3	96.0
45	R 45	30	R I-3	88.3
		29	R I-2	90.8
		29	R I-2	90.8
		29	R I-2	87.3
46	R 46	29	R I-2	95.9
		29	R I-2	95.9
		31	R I-4	89.3
		29	R I-2	93.7
47	U 47	30	R I-3	89.0
		30	R I-3	99.0
		30	R I-3	99.0
		30	R I-3	77.4
48	U 48	30	R I-3	71.2
		30	R I-3	91.2
		30	R I-3	91.2
		28	R I-1	79.7
49	U 49	28	R I-1	101.5
		28	R I-1	101.5
		28	R I-1	96.5
		28	R I-1	100.2
50	U 50	28	R I-1	103.4
		28	R I-1	93.4
		28	R I-1	98.4
		28	R I-1	102.4

TABLE Q.5

PROBS	P1	P2	P3	P4	P5	P6	P7	P8	PT
LISTENER 1									
	1.000	1.000	0.730	1.000	1.000	1.000	1.000	1.000	0.9892
	1.000	1.000	0.670	0.985	0.937	1.000	1.000	1.000	0.6851
	1.000	1.000	0.181	0.133	0.000	1.000	1.000	1.000	0.5152
	1.000	1.000	0.339	0.653	0.661	1.000	1.000	1.000	0.3585
LISTENER 2									
	1.000	1.000	0.545	0.909	0.000	1.000	1.000	1.000	0.7337
	1.000	1.000	0.728	1.000	1.000	1.000	1.000	1.000	0.7413
	1.000	1.000	0.178	0.129	0.000	1.000	1.000	1.000	0.5134
	1.000	1.000	0.452	0.825	0.935	1.000	1.000	1.000	0.4770
LISTENER 3									
	1.000	1.000	0.860	1.000	1.000	1.000	1.000	1.000	0.9944
	1.000	1.000	0.816	1.000	1.000	1.000	1.000	1.000	0.8248
	1.000	1.000	0.578	0.836	1.000	1.000	1.000	1.000	0.9093
	1.000	1.000	0.691	0.989	1.000	1.000	1.000	1.000	0.7062
LISTENER 4									
	1.000	1.000	0.736	1.000	1.000	1.000	1.000	1.000	0.9895
	1.000	1.000	0.837	1.000	1.000	1.000	1.000	1.000	0.8455
	1.000	1.000	0.540	0.771	1.000	1.000	1.000	1.000	0.8728
	1.000	1.000	0.652	0.980	1.000	1.000	1.000	1.000	0.6695
LISTENER 5									
	1.000	1.000	0.861	1.000	1.000	1.000	1.000	1.000	0.9944
	1.000	1.000	0.738	1.000	1.000	1.000	1.000	1.000	0.7514
	1.000	1.000	0.649	0.925	1.000	1.000	1.000	1.000	0.9592
	1.000	1.000	0.400	0.752	0.841	1.000	1.000	1.000	0.4241
LISTENER 6									
	1.000	1.000	0.781	1.000	1.000	1.000	1.000	1.000	0.9912
	1.000	1.000	0.727	1.000	1.000	1.000	1.000	1.000	0.7403
	1.000	1.000	0.527	0.747	1.000	1.000	1.000	1.000	0.8592
	1.000	1.000	0.552	0.929	1.000	1.000	1.000	1.000	0.5748
LISTENER 7									
	1.000	1.000	0.779	1.000	1.000	1.000	1.000	1.000	0.9912
	1.000	1.000	0.789	1.000	1.000	1.000	1.000	1.000	0.7993
	1.000	1.000	0.610	0.881	1.000	1.000	1.000	1.000	0.9346
	1.000	1.000	0.566	0.939	1.000	1.000	1.000	1.000	0.5880
LISTENER 8									
	1.000	1.000	0.922	1.000	1.000	1.000	1.000	1.000	0.9969
	1.000	1.000	0.888	1.000	1.000	1.000	1.000	1.000	0.8935
	1.000	1.000	0.802	1.000	1.000	1.000	1.000	1.000	1.0010
	1.000	1.000	0.684	0.988	1.000	1.000	1.000	1.000	0.7002
LISTENER 9									
	1.000	1.000	0.704	0.998	0.999	1.000	1.000	1.000	0.9876
	1.000	1.000	0.804	1.000	1.000	1.000	1.000	1.000	0.8141
	1.000	1.000	0.631	0.907	1.000	1.000	1.000	1.000	0.9491
	1.000	1.000	0.594	0.956	1.000	1.000	1.000	1.000	0.6146
LISTENER 10									
	1.000	1.000	0.782	1.000	1.000	1.000	1.000	1.000	0.9913
	1.000	1.000	0.873	1.000	1.000	1.000	1.000	1.000	0.8792
	1.000	1.000	0.728	0.979	1.000	1.000	1.000	1.000	0.9890
	1.000	1.000	0.713	1.000	1.000	1.000	1.000	1.000	0.7273

TABLE Q.5 (Continued)

LISTENER 11								
1.000	1.000	0.753	1.000	1.000	1.000	1.000	1.000	0.9901
1.000	1.000	0.721	1.000	1.000	1.000	1.000	1.000	0.7346
1.000	1.000	0.519	0.732	1.000	1.000	1.000	1.000	0.8507
1.000	1.000	0.439	0.807	0.916	1.000	1.000	1.000	0.4634
LISTENER 12								
1.000	1.000	0.792	1.000	1.000	1.000	1.000	1.000	0.9917
1.000	1.000	0.839	1.000	1.000	1.000	1.000	1.000	0.8470
1.000	1.000	0.543	0.776	1.000	1.000	1.000	1.000	0.8757
1.000	1.000	0.655	0.981	1.000	1.000	1.000	1.000	0.6723
LISTENER 13								
1.000	1.000	0.563	0.924	0.000	1.000	1.000	1.000	0.7374
1.000	1.000	0.724	1.000	1.000	1.000	1.000	1.000	0.7382
1.000	1.000	0.339	0.359	0.660	1.000	1.000	1.000	0.6418
1.000	1.000	0.441	0.811	0.920	1.000	1.000	1.000	0.4661
LISTENER 14								
1.000	1.000	0.750	1.000	1.000	1.000	1.000	1.000	0.9900
1.000	1.000	0.658	0.982	0.915	1.000	1.000	1.000	0.6730
1.000	1.000	0.438	0.564	0.915	1.000	1.000	1.000	0.7567
1.000	1.000	0.499	0.881	0.999	1.000	1.000	1.000	0.5244
LISTENER 15								
1.000	1.000	0.709	0.999	1.000	1.000	1.000	1.000	0.9882
1.000	1.000	0.807	1.000	1.000	1.000	1.000	1.000	0.8169
1.000	1.000	0.635	0.899	1.000	1.000	1.000	1.000	0.9444
1.000	1.000	0.611	0.955	1.000	1.000	1.000	1.000	0.6301
LISTENER 16								
1.000	1.000	0.734	1.000	1.000	1.000	1.000	1.000	0.9894
1.000	1.000	0.695	0.993	0.993	1.000	1.000	1.000	0.7099
1.000	1.000	0.485	0.664	0.993	1.000	1.000	1.000	0.8126
1.000	1.000	0.459	0.834	0.943	1.000	1.000	1.000	0.4837
LISTENER 17								
1.000	1.000	0.860	1.000	1.000	1.000	1.000	1.000	0.9944
1.000	1.000	0.766	1.000	1.000	1.000	1.000	1.000	0.7776
1.000	1.000	0.579	0.837	1.000	1.000	1.000	1.000	0.9099
1.000	1.000	0.690	0.989	1.000	1.000	1.000	1.000	0.7051
LISTENER 18								
1.000	1.000	0.914	1.000	1.000	1.000	1.000	1.000	0.9966
1.000	1.000	0.914	1.000	1.000	1.000	1.000	1.000	0.9183
1.000	1.000	0.790	1.000	1.000	1.000	1.000	1.000	1.0010
1.000	1.000	0.782	1.000	1.000	1.000	1.000	1.000	0.7928
LISTENER 19								
1.000	1.000	0.845	1.000	1.000	1.000	1.000	1.000	0.9938
1.000	1.000	0.845	1.000	1.000	1.000	1.000	1.000	0.8529
1.000	1.000	0.624	0.882	1.000	1.000	1.000	1.000	0.9351
1.000	1.000	0.673	0.980	1.000	1.000	1.000	1.000	0.6893
LISTENER 20								
1.000	1.000	0.602	0.950	0.480	1.000	1.000	1.000	0.8543
1.000	1.000	0.781	1.000	1.000	1.000	1.000	1.000	0.7915
1.000	1.000	0.599	0.866	1.000	1.000	1.000	1.000	0.9262
1.000	1.000	0.547	0.925	1.000	1.000	1.000	1.000	0.5698

TABLE Q.5 (Continued)

LISTENER 21								
1.000	1.000	0.711	1.000	1.000	1.000	1.000	1.000	0.9883
1.000	1.000	0.781	1.000	1.000	1.000	1.000	1.000	0.7915
1.000	1.000	0.599	0.866	1.000	1.000	1.000	1.000	0.9262
1.000	1.000	0.547	0.925	1.000	1.000	1.000	1.000	0.5897
LISTENER 22								
1.000	1.000	0.753	1.000	1.000	1.000	1.000	1.000	0.9901
1.000	1.000	0.753	1.000	1.000	1.000	1.000	1.000	0.7654
1.000	1.000	0.485	0.585	0.942	1.000	1.000	1.000	0.7688
1.000	1.000	0.495	0.877	0.999	1.000	1.000	1.000	0.5206
LISTENER 23								
1.000	1.000	0.797	1.000	1.000	1.000	1.000	1.000	0.9919
1.000	1.000	0.720	1.000	1.000	1.000	1.000	1.000	0.7339
1.000	1.000	0.518	0.730	1.000	1.000	1.000	1.000	0.8496
1.000	1.000	0.431	0.797	0.903	1.000	1.000	1.000	0.4555
LISTENER 24								
1.000	1.000	0.829	1.000	1.000	1.000	1.000	1.000	0.9932
1.000	1.000	0.706	0.999	0.999	1.000	1.000	1.000	0.7205
1.000	1.000	0.599	0.866	1.000	1.000	1.000	1.000	0.9262
1.000	1.000	0.403	0.756	0.847	1.000	1.000	1.000	0.4267
LISTENER 25								
1.000	1.000	0.569	0.941	0.613	1.000	1.000	1.000	0.8820
1.000	1.000	0.671	0.985	0.937	1.000	1.000	1.000	0.6851
1.000	1.000	0.454	0.597	0.937	1.000	1.000	1.000	0.7754
1.000	1.000	0.000	0.240	0.000	1.000	1.000	1.000	0.0100
LISTENER 26								
1.000	1.000	0.466	0.843	0.000	1.000	1.000	1.000	0.7173
0.718	1.000	0.229	0.534	0.000	1.000	1.000	1.000	0.2379
0.718	1.000	0.000	0.012	0.000	1.000	1.000	1.000	0.4339
0.571	1.000	0.000	0.000	0.000	1.000	1.000	1.000	0.0100
LISTENER 27								
1.000	1.000	0.658	0.982	0.915	1.000	1.000	1.000	0.9633
1.000	1.000	0.824	1.000	1.000	1.000	1.000	1.000	0.8329
1.000	1.000	0.518	0.729	1.000	1.000	1.000	1.000	0.8494
1.000	1.000	0.629	0.972	1.000	1.000	1.000	1.000	0.6477
LISTENER 28								
1.000	1.000	0.845	1.000	1.000	1.000	1.000	1.000	0.9938
1.000	1.000	0.623	0.970	0.823	1.000	1.000	1.000	0.6364
1.000	1.000	0.552	0.793	1.000	1.000	1.000	1.000	0.8853
1.000	1.000	0.362	0.691	0.735	1.000	1.000	1.000	0.3830
LISTENER 29								
1.000	1.000	0.714	1.000	1.000	1.000	1.000	1.000	0.9885
1.000	1.000	0.805	1.000	1.000	1.000	1.000	1.000	0.8150
1.000	1.000	0.632	0.895	1.000	1.000	1.000	1.000	0.9423
1.000	1.000	0.607	0.953	1.000	1.000	1.000	1.000	0.6269
LISTENER 30								
1.000	1.000	0.718	1.000	1.000	1.000	1.000	1.000	0.9887
1.000	1.000	0.748	1.000	1.000	1.000	1.000	1.000	0.7603
1.000	1.000	0.555	0.798	1.000	1.000	1.000	1.000	0.8876
1.000	1.000	0.485	0.865	0.993	1.000	1.000	1.000	0.5107

TABLE Q.5 (Continued)

LISTENER 31								
1.000	1.000	0.734	1.000	1.000	1.000	1.000	1.000	0.9894
1.000	1.000	0.788	1.000	1.000	1.000	1.000	1.000	0.7984
1.000	1.000	0.474	0.639	0.969	1.000	1.000	1.000	0.7988
1.000	1.000	0.578	0.935	1.000	1.000	1.000	1.000	0.5990
LISTENER 32								
1.000	1.000	0.946	1.000	1.000	1.000	1.000	1.000	0.9979
1.000	1.000	0.946	1.000	1.000	1.000	1.000	1.000	0.9491
1.000	1.000	0.843	1.000	1.000	1.000	1.000	1.000	1.0010
1.000	1.000	0.839	1.000	1.000	1.000	1.000	1.000	0.8470
LISTENER 33								
1.000	1.000	0.795	1.000	1.000	1.000	1.000	1.000	0.9918
1.000	1.000	0.758	1.000	1.000	1.000	1.000	1.000	0.7656
1.000	1.000	0.510	0.714	1.000	1.000	1.000	1.000	0.8406
1.000	1.000	0.509	0.891	1.000	1.000	1.000	1.000	0.5334
LISTENER 34								
1.000	1.000	0.769	1.000	1.000	1.000	1.000	1.000	0.9908
1.000	1.000	0.863	1.000	1.000	1.000	1.000	1.000	0.8694
1.000	1.000	0.713	0.972	1.000	1.000	1.000	1.000	0.9853
1.000	1.000	0.695	0.994	1.000	1.000	1.000	1.000	0.7106
LISTENER 35								
1.000	1.000	0.883	1.000	1.000	1.000	1.000	1.000	0.9953
1.000	1.000	0.796	1.000	1.000	1.000	1.000	1.000	0.8059
1.000	1.000	0.743	0.997	1.000	1.000	1.000	1.000	0.9996
1.000	1.000	0.453	0.827	0.936	1.000	1.000	1.000	0.4780
LISTENER 36								
1.000	1.000	0.773	1.000	1.000	1.000	1.000	1.000	0.9909
1.000	1.000	0.773	1.000	1.000	1.000	1.000	1.000	0.7843
1.000	1.000	0.532	0.756	1.000	1.000	1.000	1.000	0.8642
1.000	1.000	0.537	0.917	1.000	1.000	1.000	1.000	0.5605
LISTENER 37								
1.000	1.000	0.769	1.000	1.000	1.000	1.000	1.000	0.9908
1.000	1.000	0.797	1.000	1.000	1.000	1.000	1.000	0.8074
1.000	1.000	0.621	0.879	1.000	1.000	1.000	1.000	0.9333
1.000	1.000	0.594	0.945	1.000	1.000	1.000	1.000	0.6142
LISTENER 38								
1.000	1.000	0.775	1.000	1.000	1.000	1.000	1.000	0.9910
1.000	1.000	0.731	1.000	1.000	1.000	1.000	1.000	0.7441
1.000	1.000	0.532	0.701	1.000	1.000	1.000	1.000	0.8335
1.000	1.000	0.380	0.720	0.787	1.000	1.000	1.000	0.4021
LISTENER 39								
1.000	1.000	0.728	1.000	1.000	1.000	1.000	1.000	0.9891
1.000	1.000	0.751	1.000	1.000	1.000	1.000	1.000	0.7632
1.000	1.000	0.540	0.721	1.000	1.000	1.000	1.000	0.8445
1.000	1.000	0.509	0.891	1.000	1.000	1.000	1.000	0.5337
LISTENER 40								
1.000	1.000	0.884	1.000	1.000	1.000	1.000	1.000	0.9954
1.000	1.000	0.884	1.000	1.000	1.000	1.000	1.000	0.8896
1.000	1.000	0.744	0.998	1.000	1.000	1.000	1.000	0.9998
1.000	1.000	0.731	1.000	1.000	1.000	1.000	1.000	0.7448

TABLE Q.5 (Continued)

	1.000	0.743	1.000	1.000	1.000	1.000	1.000	0.9897
	1.000	0.883	1.000	1.000	1.000	1.000	1.000	0.8886
	1.000	0.743	0.997	1.000	1.000	1.000	1.000	0.9995
	1.000	1.000	0.730	1.000	1.000	1.000	1.000	0.7432
LISTENER 42								
	1.000	1.000	0.818	1.000	1.000	1.000	1.000	0.9927
	1.000	1.000	0.739	1.000	1.000	1.000	1.000	0.7522
	1.000	1.000	0.543	0.778	1.000	1.000	1.000	0.8764
	1.000	1.000	0.474	0.853	0.972	1.000	1.000	0.4995
LISTENER 43								
	1.000	1.000	0.826	1.000	1.000	1.000	1.000	0.9931
	1.000	1.000	0.731	1.000	1.000	1.000	1.000	0.7448
	1.000	1.000	0.595	0.861	1.000	1.000	1.000	0.9230
	1.000	1.000	0.459	0.835	0.944	1.000	1.000	0.4841
LISTENER 44								
	1.000	1.000	0.843	1.000	1.000	1.000	1.000	0.9937
	1.000	1.000	0.743	1.000	1.000	1.000	1.000	0.7562
	1.000	1.000	0.549	0.787	1.000	1.000	1.000	0.8819
	1.000	1.000	0.661	0.983	1.000	1.000	1.000	0.6783
LISTENER 45								
	1.000	1.000	0.748	1.000	1.000	1.000	1.000	0.9899
	1.000	1.000	0.775	1.000	1.000	1.000	1.000	0.7862
	1.000	1.000	0.591	0.856	1.000	1.000	1.000	0.9202
	1.000	1.000	0.541	0.920	1.000	1.000	1.000	0.5641
LISTENER 46								
	1.000	1.000	0.826	1.000	1.000	1.000	1.000	0.9930
	1.000	1.000	0.826	1.000	1.000	1.000	1.000	0.8343
	1.000	1.000	0.570	0.822	1.000	1.000	1.000	0.9016
	1.000	1.000	0.632	0.973	1.000	1.000	1.000	0.6502
LISTENER 47								
	1.000	1.000	0.756	1.000	1.000	1.000	1.000	0.9903
	1.000	1.000	0.853	1.000	1.000	1.000	1.000	0.8602
	1.000	1.000	0.699	0.964	1.000	1.000	1.000	0.9811
	1.000	1.000	0.381	0.722	0.792	1.000	1.000	0.4037
LISTENER 48								
	1.000	1.000	0.524	0.905	0.412	1.000	1.000	0.8266
	1.000	1.000	0.779	1.000	1.000	1.000	1.000	0.7899
	1.000	1.000	0.596	0.863	1.000	1.000	1.000	0.9245
	1.000	1.000	0.420	0.781	0.883	1.000	1.000	0.4440
LISTENER 49								
	1.000	1.000	0.873	1.000	1.000	1.000	1.000	0.9949
	1.000	1.000	0.873	1.000	1.000	1.000	1.000	0.8791
	1.000	1.000	0.667	0.942	1.000	1.000	1.000	0.9687
	1.000	1.000	0.713	1.000	1.000	1.000	1.000	0.7271
LISTENER 50								
	1.000	1.000	0.888	1.000	1.000	1.000	1.000	0.9955
	1.000	1.000	0.802	1.000	1.000	1.000	1.000	0.8117
	1.000	1.000	0.692	0.960	1.000	1.000	1.000	0.9786
	1.000	1.000	0.738	1.000	1.000	1.000	1.000	0.7510

RURAL, URBAN POPULATIONS ? 33201,268629

PTRUR	PTURB	PTALL
0.956	0.974	0.972
0.741	0.807	0.800
0.847	0.896	0.890
0.508	0.591	0.582

DISTRIBUTION LIST

No. of
Copies

OFFSITE

	A. A. Churm DOE Patent Division 9800 S. Cass Avenue Argonne, IL 60439	AV Robinson PD Robinson JM Selby GA Stoetzel KL Swinth VW Thomas
100	U.S. Nuclear Regulatory Commission Division of Technical Information and Document Control 7920 Norfolk Avenue Bethesda, MD 20014	Technical Information (5) Publishing Coordination (2)
2	DOE Technical Information Center Office of Inspection and Enforcement Division of Emergency Preparedness Emergency Preparedness Development Branch Air Rights Building 4450 Montgomery Bethesda, MD 20014	
	Pacific Northwest Laboratory (34)	
	EH Carbaugh CJ Card CD Corbit PL Cummings AE Desrosiers TH Essig RL Gilchrist SC Hawley WN Herrington III EE Hickey CD Hooker JL Kenoyer GJ Laughlin JC Mann GA Martin MA McLean MP Moeller LH Munson BL Murphy BD Pickett RW Poeton	

NRC FORM 335 <small>(11-81)</small>		U.S. NUCLEAR REGULATORY COMMISSION BIBLIOGRAPHIC DATA SHEET		1. REPORT NUMBER (Assigned by DDC) NUREG/CR-2655 PNL-4226	
4. TITLE AND SUBTITLE (Add Volume No., if appropriate) Evaluation of the Prompt Alerting Systems at Four Nuclear Power Stations				2. (Leave blank)	
7. AUTHOR(S) D.A. Towers, G.S. Anderson, D.N. Keast/BB&N J.L. Kenoyer, A.E. Desrosiers/PNL				5. DATE REPORT COMPLETED MONTH February YEAR 1982	
9. PERFORMING ORGANIZATION NAME AND MAILING ADDRESS (Include Zip Code) Bolt Beranek & Newman Inc. Pacific Northwest Laboratory 10 Moulton Street P. O. Box 999 Cambridge, MA 02238 Richland, WA 99352				DATE REPORT ISSUED MONTH September YEAR 1982	
12. SPONSORING ORGANIZATION NAME AND MAILING ADDRESS (Include Zip Code) Division of Emergency Preparedness Office of Inspection and Enforcement U.S. Nuclear Regulatory Commission Washington, D. C. 20555				6. (Leave blank)	
				8. (Leave blank)	
				10. PROJECT/TASK/WORK UNIT NO.	
				11. FIN NO. B2311	
13. TYPE OF REPORT			PERIOD COVERED (Inclusive dates)		
15. SUPPLEMENTARY NOTES				14. (Leave blank)	
16. ABSTRACT (200 words or less) <p>This report presents evaluations of the prompt notification siren systems at the following four U.S. nuclear power facilities: Trojan, Three Mile Island, Indian Point, and Zion. The objective of these evaluations was to provide examples of an analytical procedure for predicting siren-system effectiveness under specific conditions in the 10-mile emergency planning zone (EPZ) surrounding nuclear power plants. This analytical procedure is discussed in NUREG/CR-2654.</p>					
17. KEY WORDS AND DOCUMENT ANALYSIS			17a. DESCRIPTORS		
17b. IDENTIFIERS/OPEN-ENDED TERMS					
18. AVAILABILITY STATEMENT Unlimited			19. SECURITY CLASS (This report) Unclassified		21. NO. OF PAGES
			20. SECURITY CLASS (This page) Unclassified		22. PRICE S

**UNITED STATES
NUCLEAR REGULATORY COMMISSION
WASHINGTON, D.C. 20555**

OFFICIAL BUSINESS
PENALTY FOR PRIVATE USE, \$300

FOURTH CLASS MAIL
POSTAGE & FEES PAID
USNRC
WASH D C
PERMIT No G-62